

# 01 OFF-ROADER

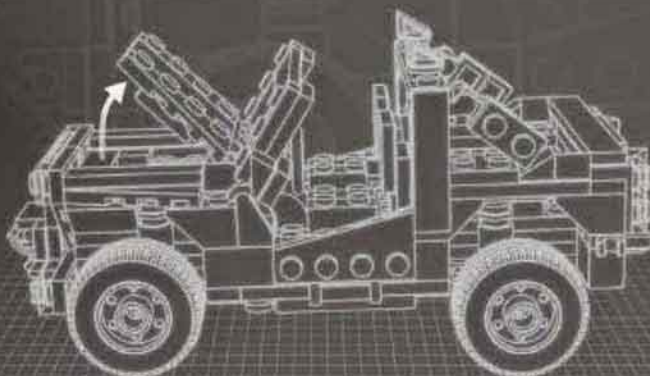

Complexity   
Functions   
Pieces 

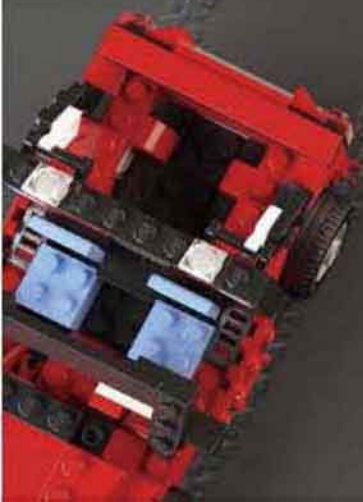
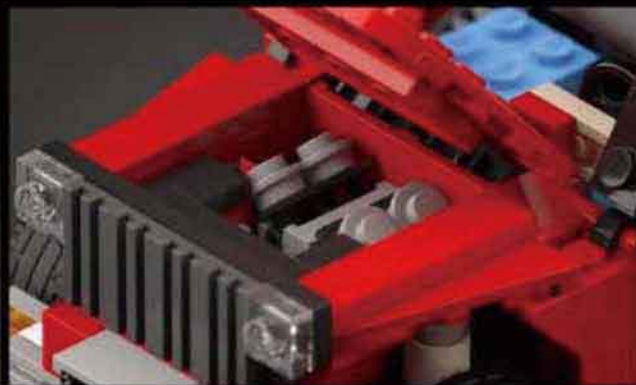

## OFF-ROADER

**Design notes:** wide wheelbase, high clearance, exposed shock absorbers, front-bumper winch, spotlights

### Technical specifications:

Dimensions (l x w x h): 20 x 10 x 10 studs  
Wheelbase: 11 studs  
Axle width front/rear: 10/10 studs

**Features:** hinged hood, V4 engine, rear accessory clips



1

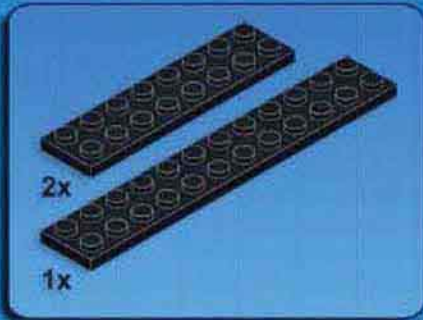

2

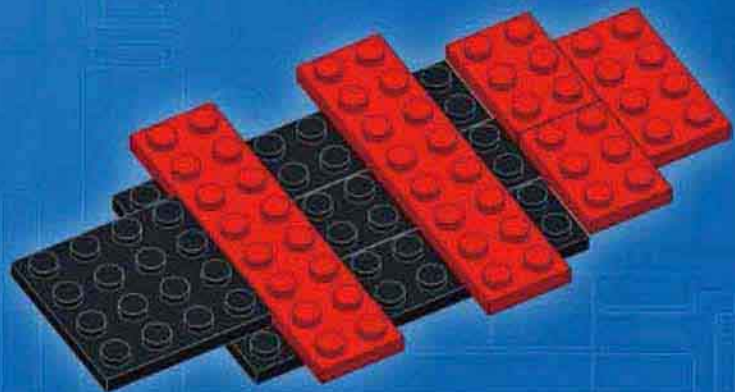
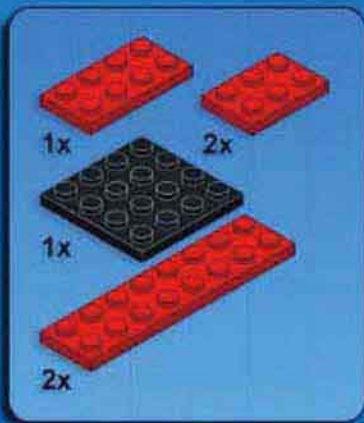

3

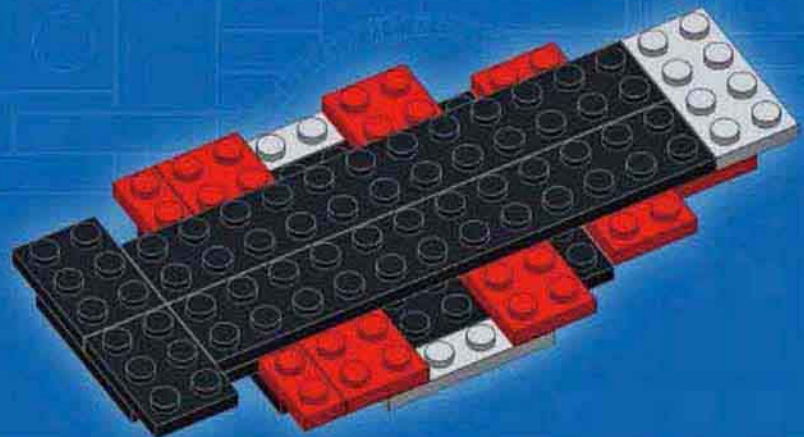
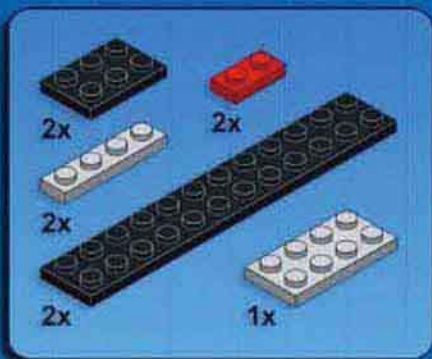

4

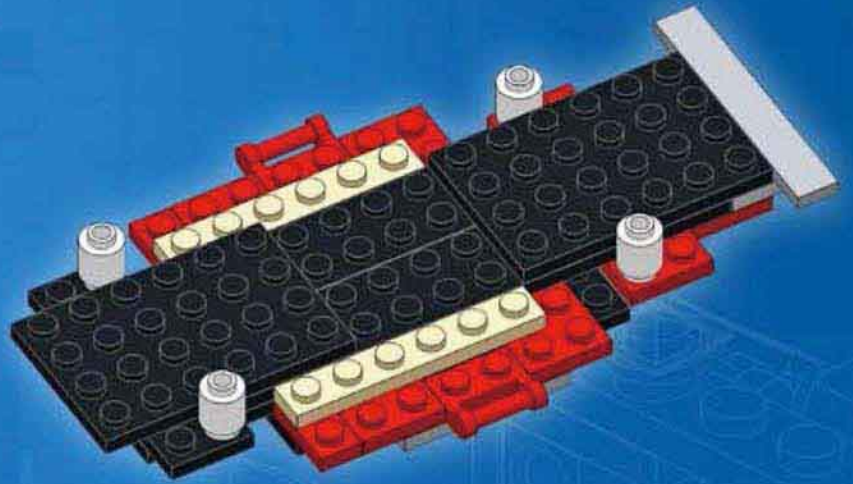

5

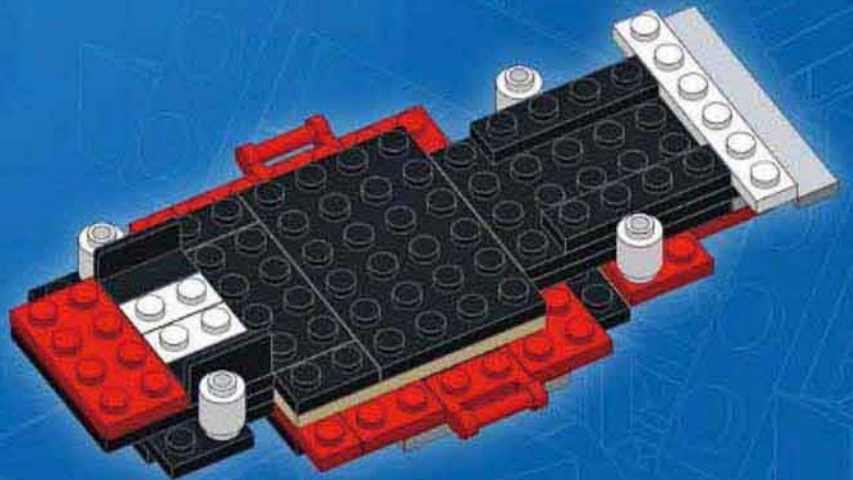
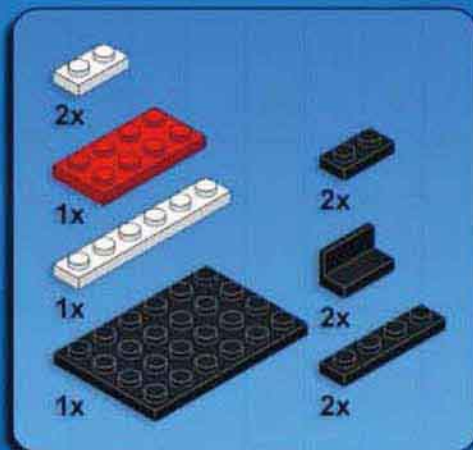

6

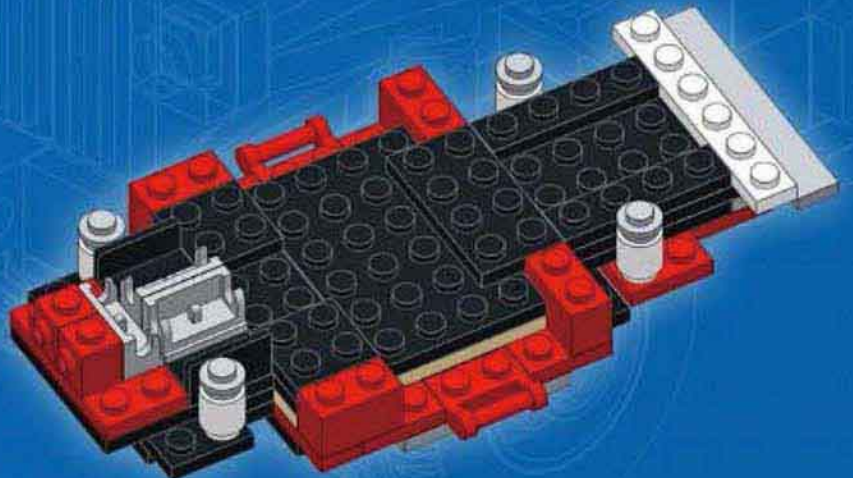
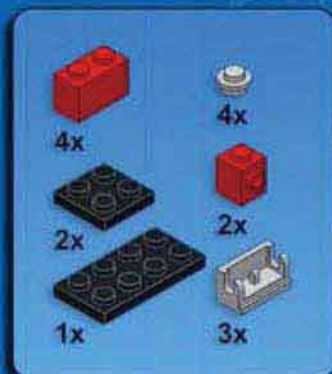



7

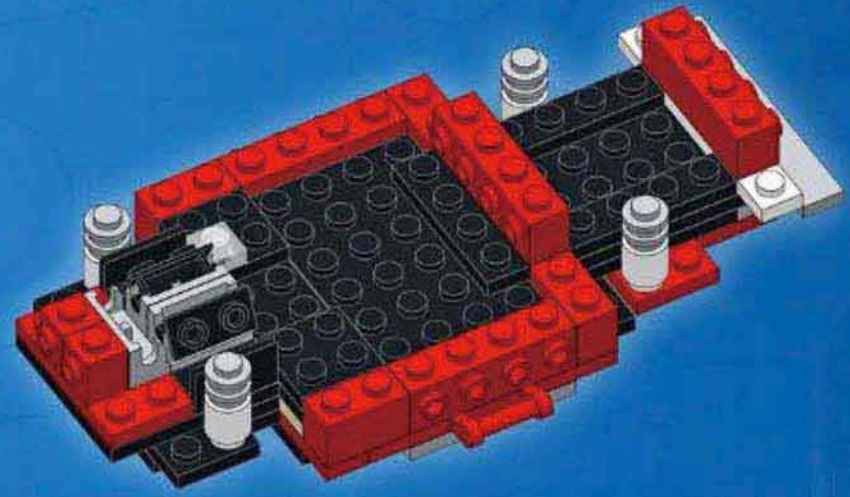
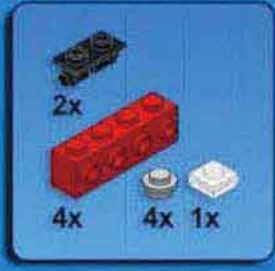

8

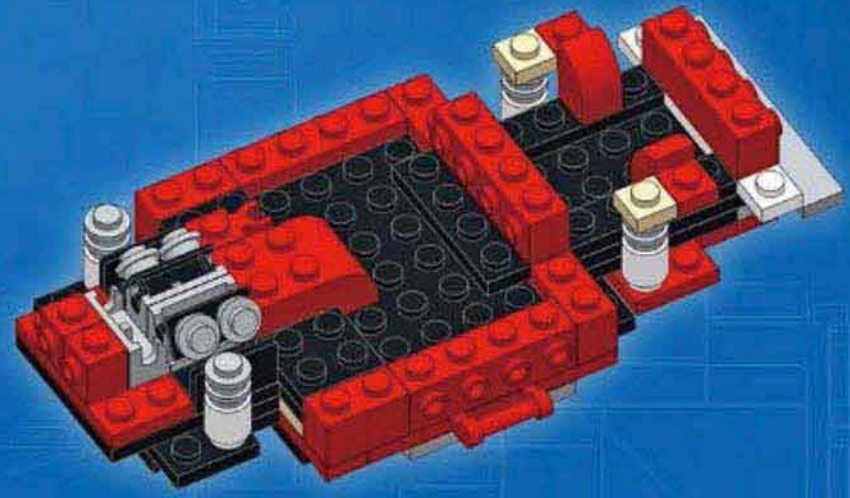
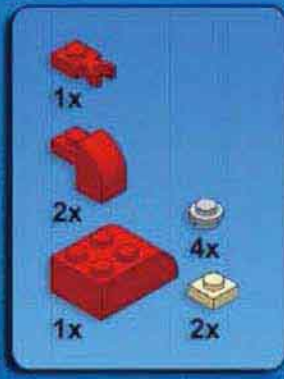

9

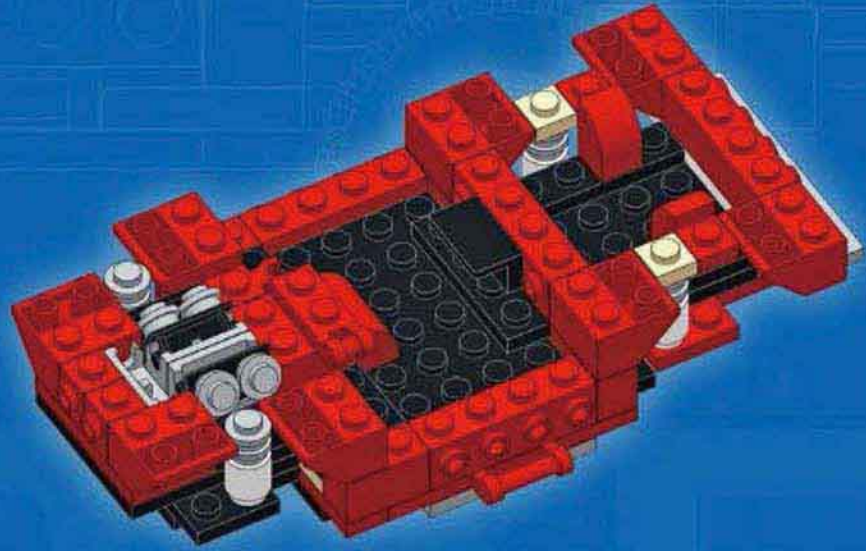
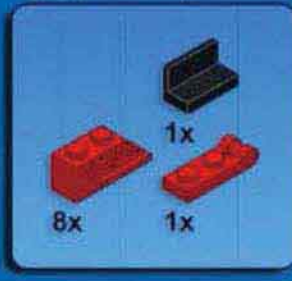

10

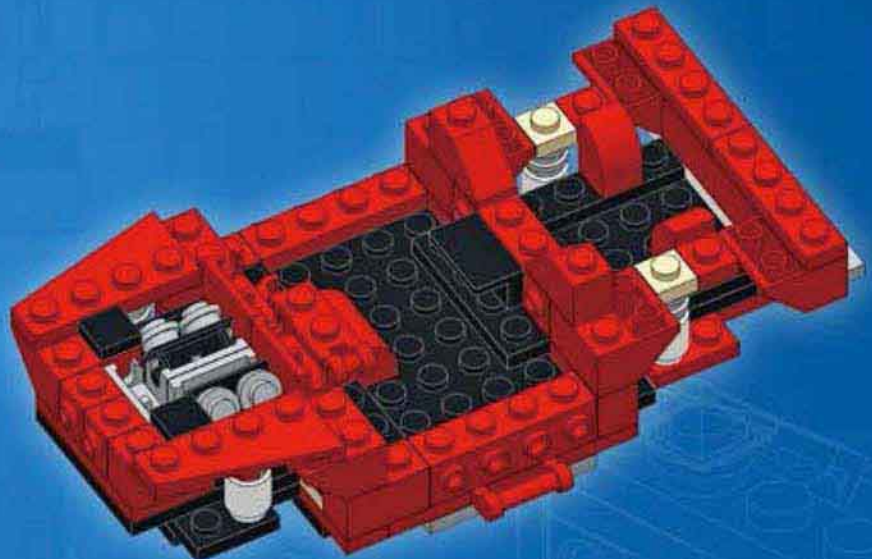
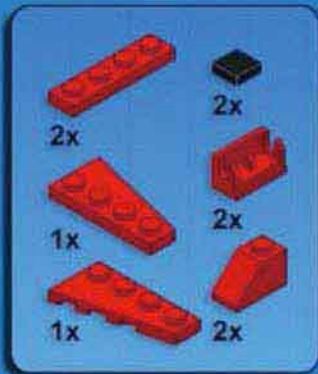

11

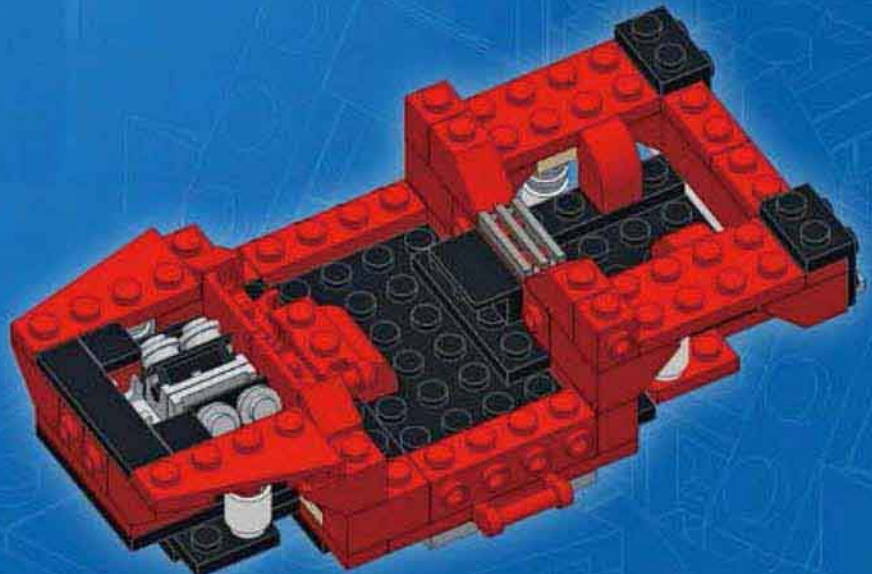
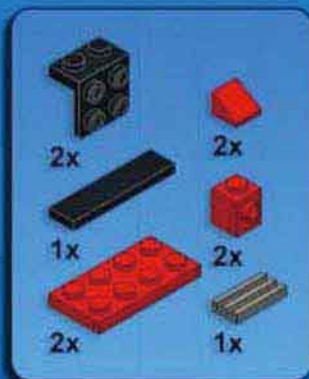

12

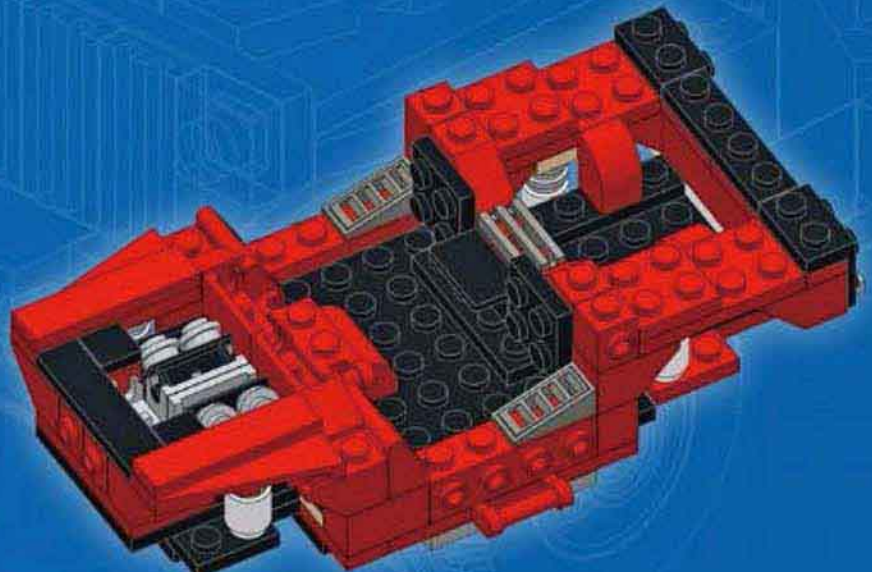
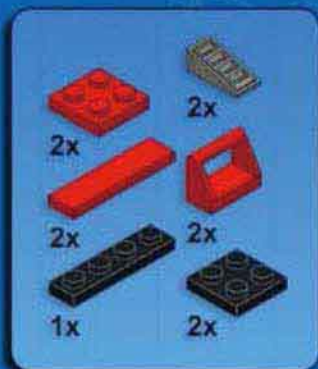



13

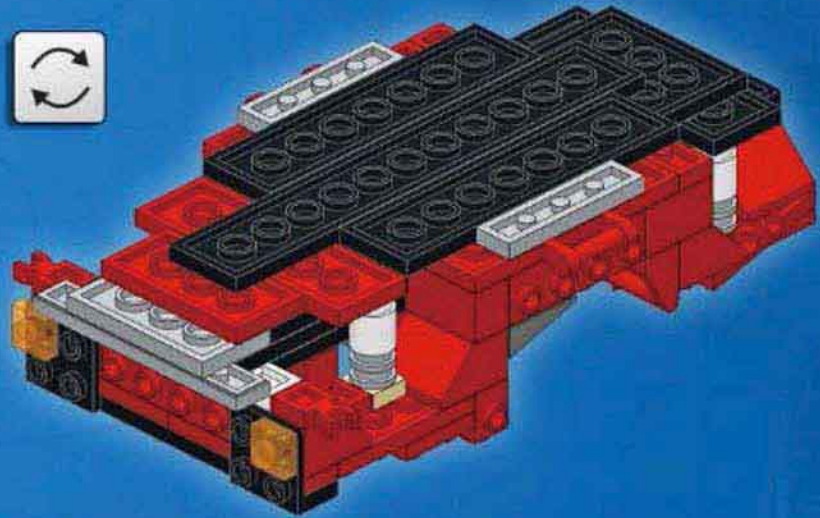

14

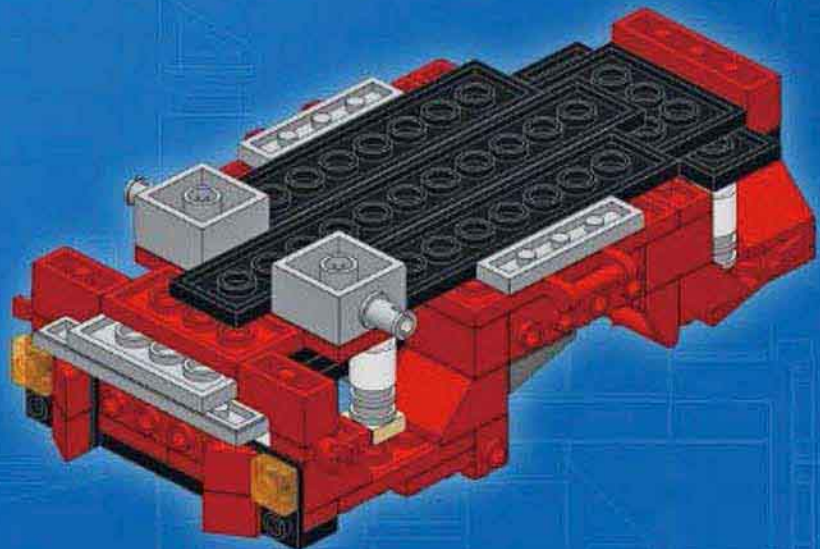
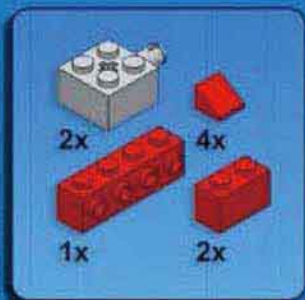

15

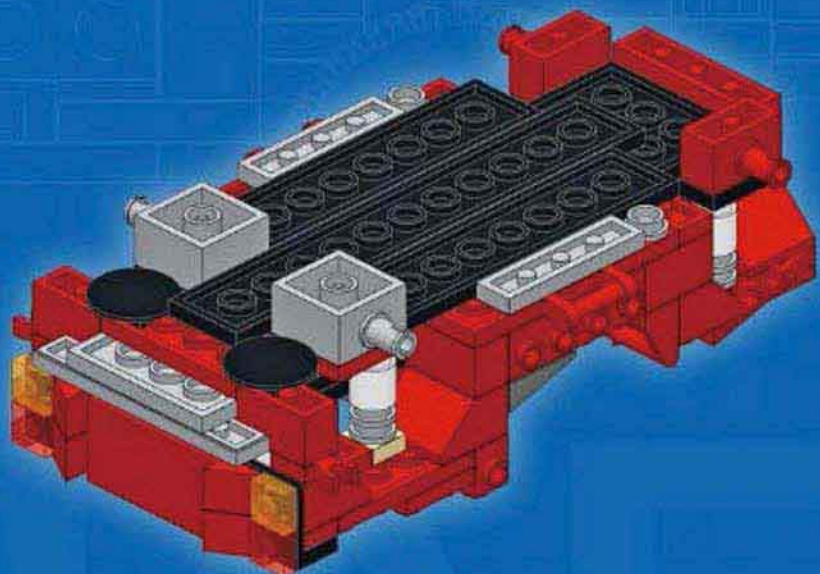
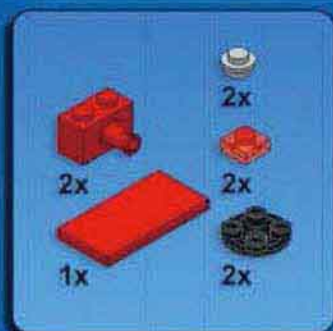



16

- 4x
- 1x
- 1x

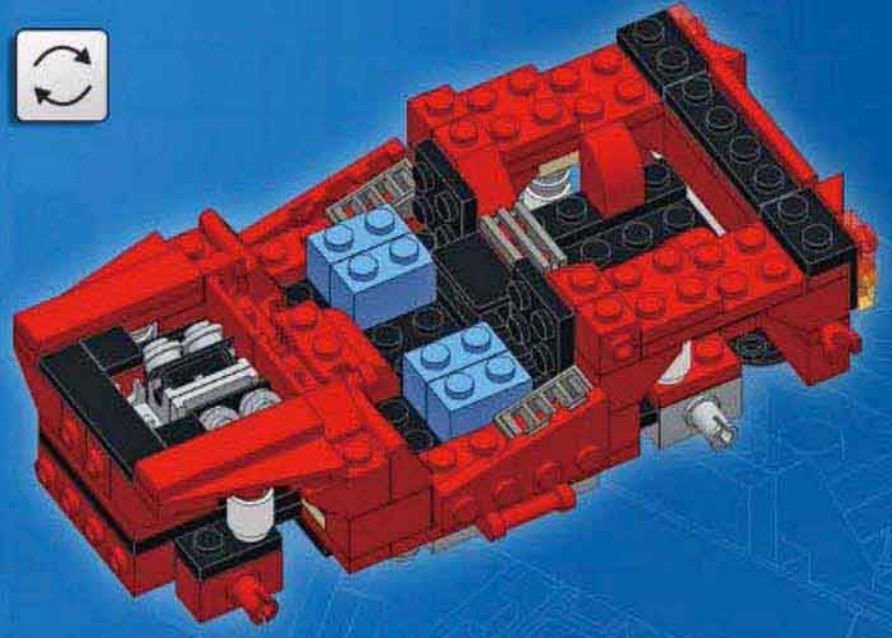

17

- 2x
- 1x
- 2x
- 2x
- 2x

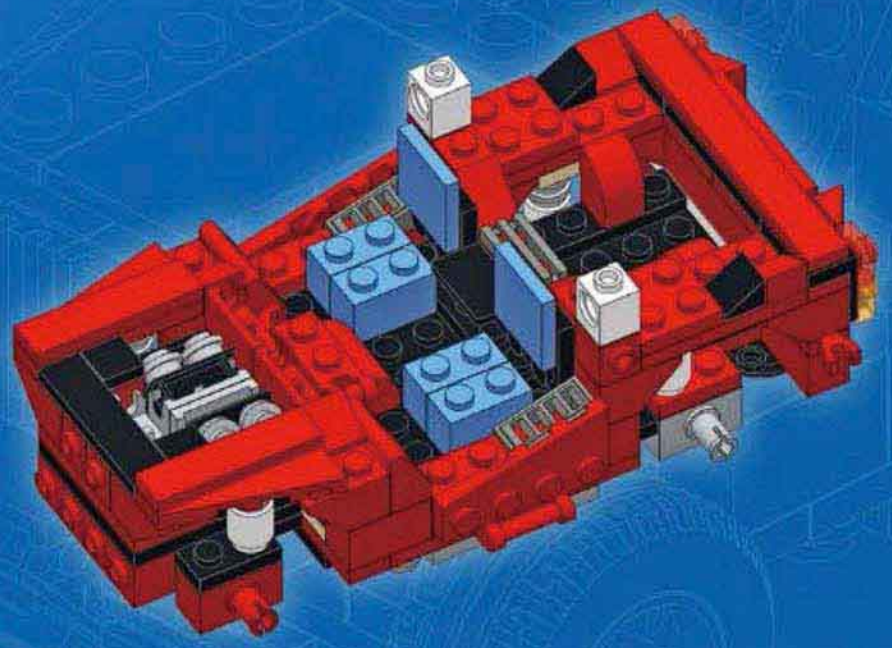

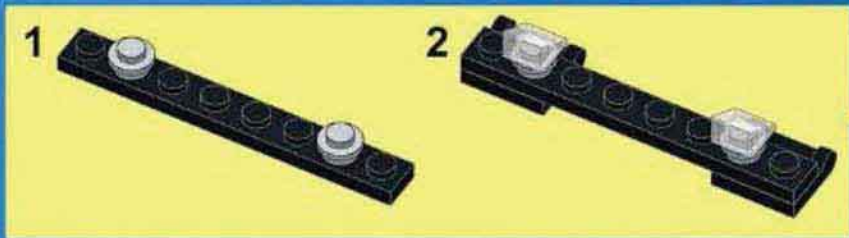
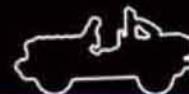

18

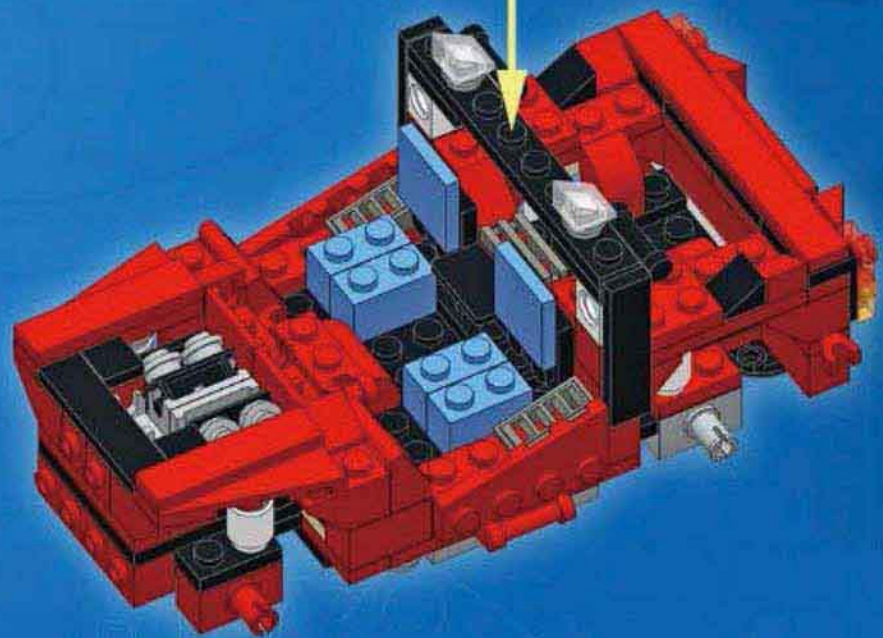
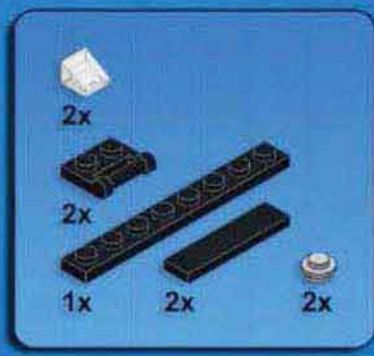

19

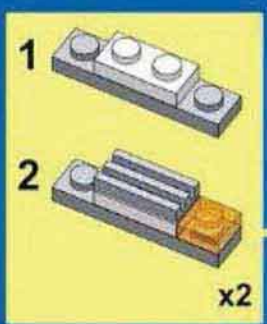
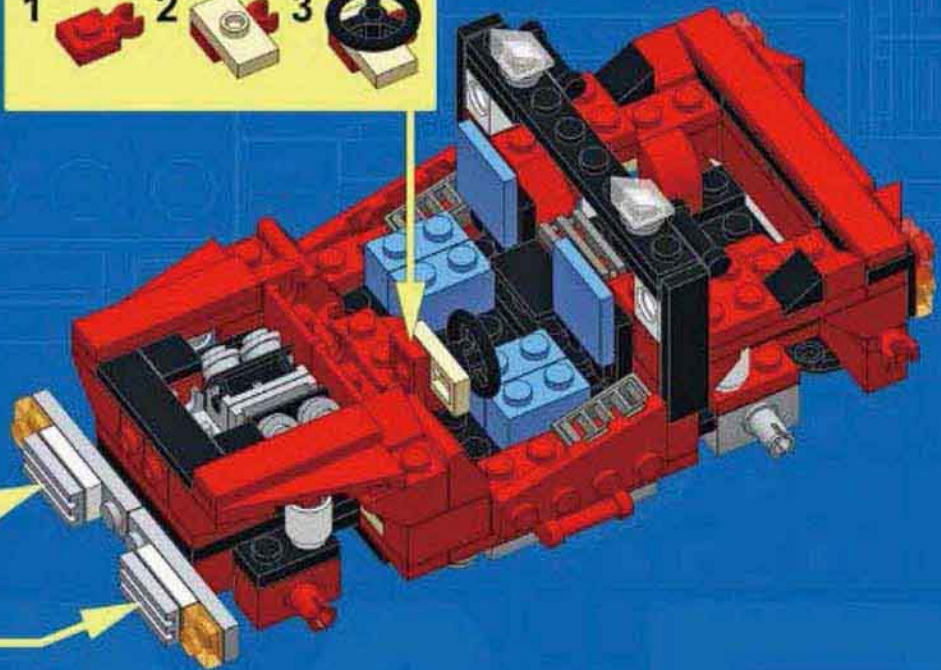



20

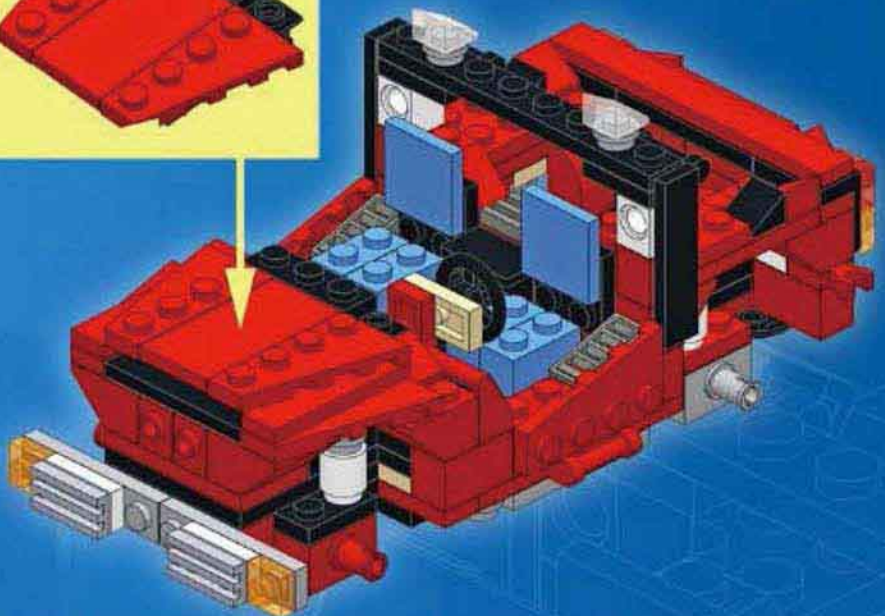
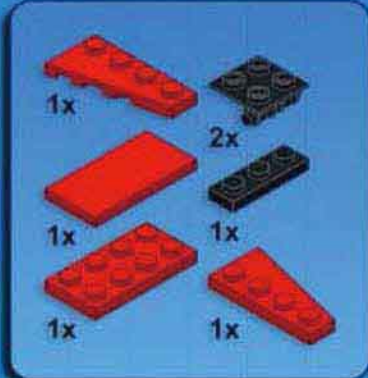
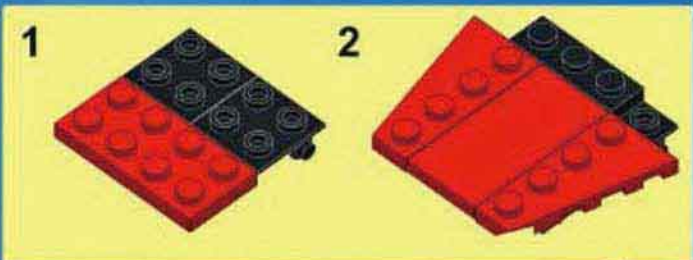

21

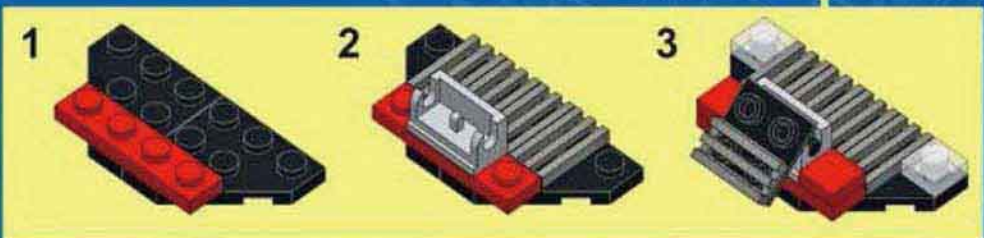
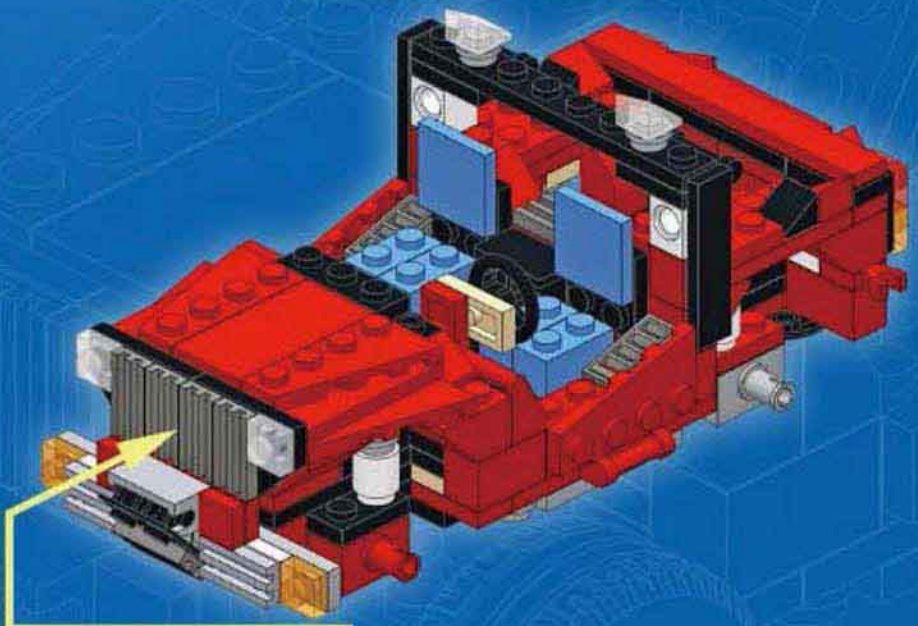
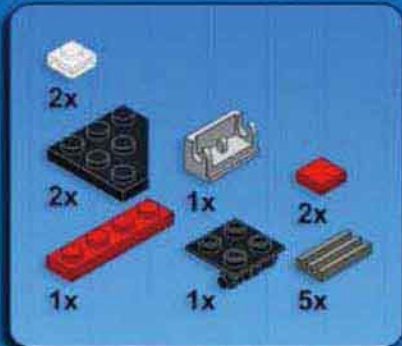

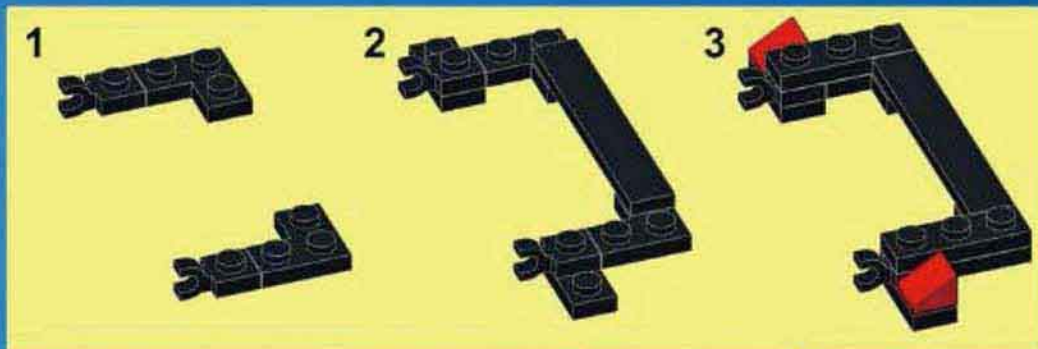

22

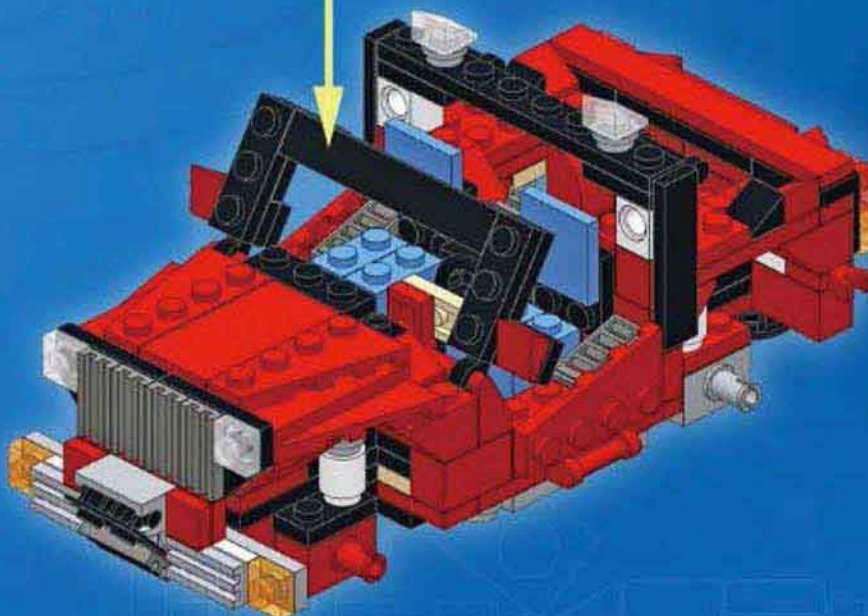
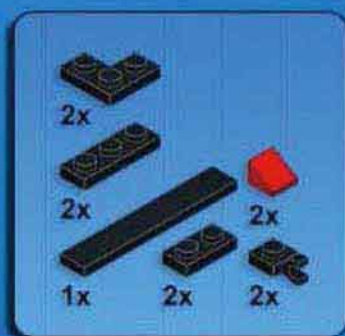

23

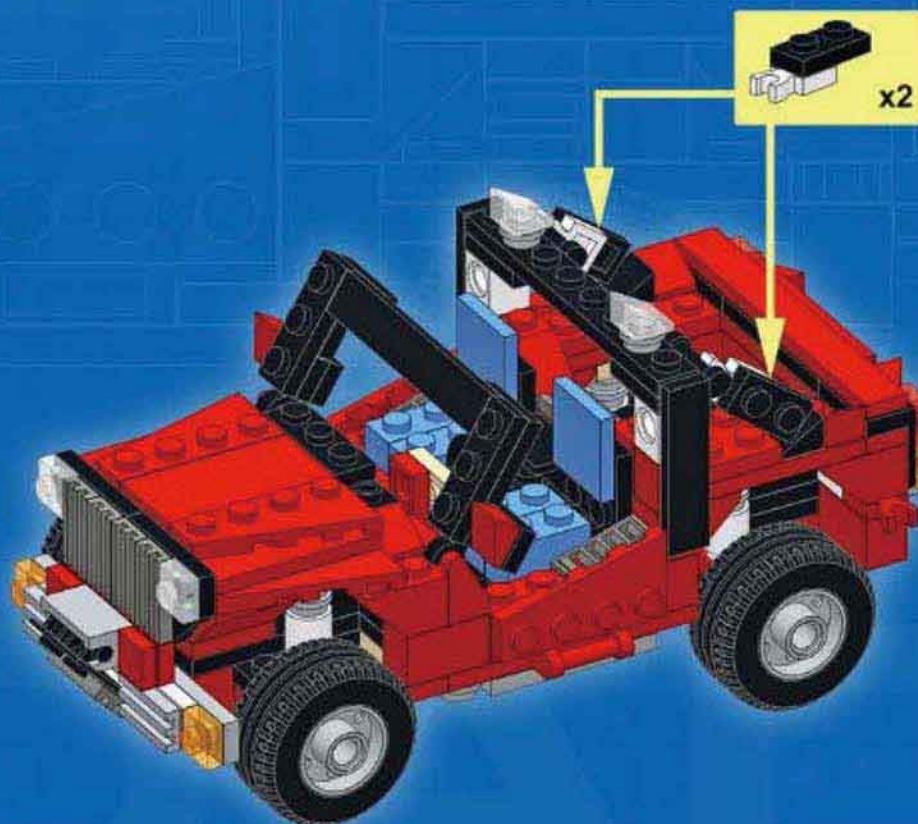

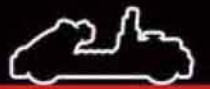

Complexity  
Functions  
Pieces

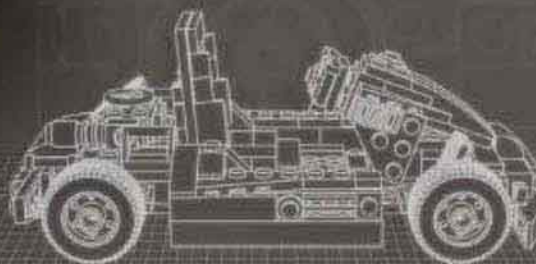

## GO-KART

Design notes: wide and low chassis, single-cylinder engine, large seat, small wheels, gas and brake pedals

### Technical specifications:

Dimensions (l × w × h): 21 × 12 × 9 studs

Wheelbase: 14 studs

Axle width front/rear: 12/12 studs



1

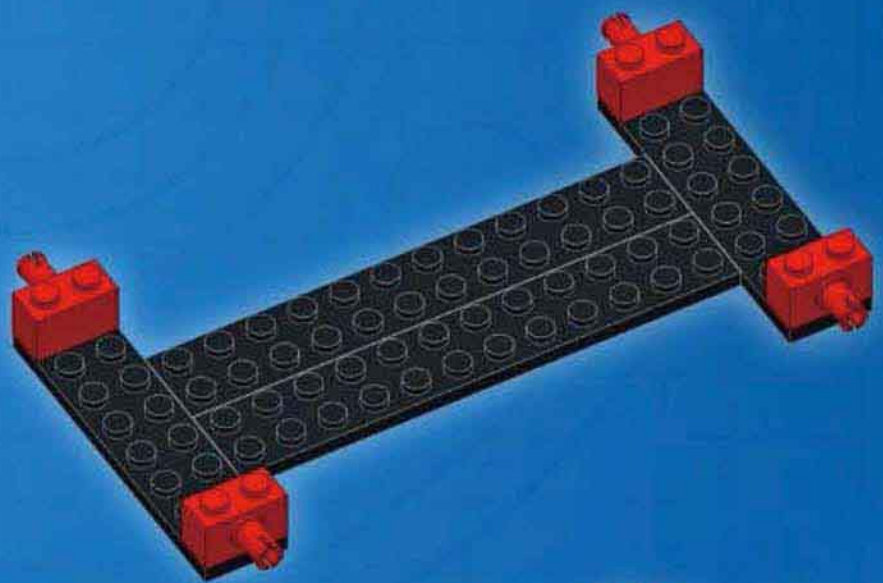
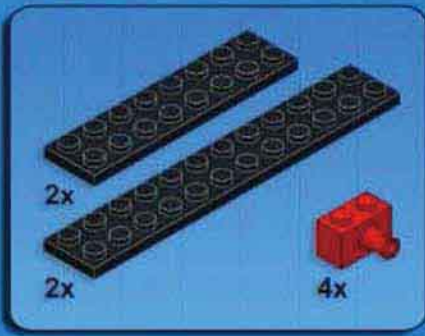

2

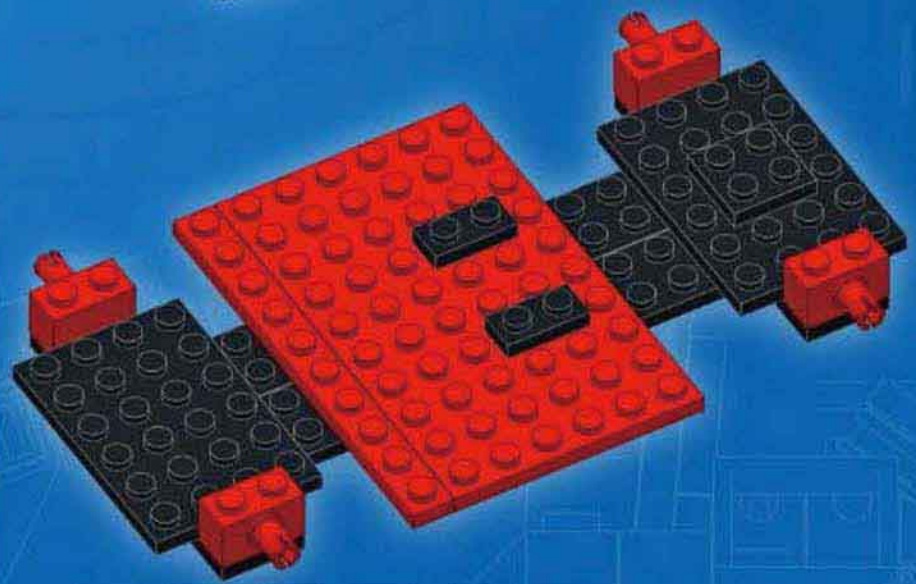
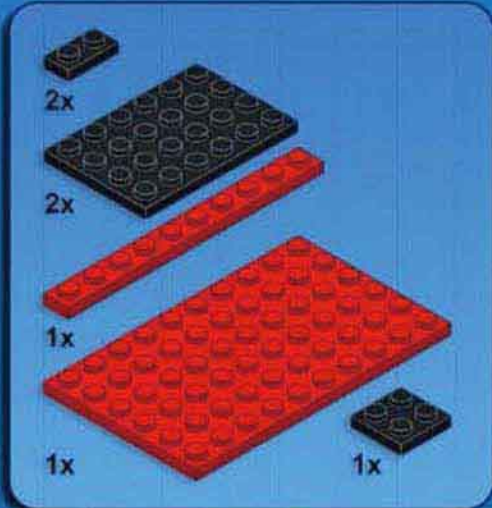

3

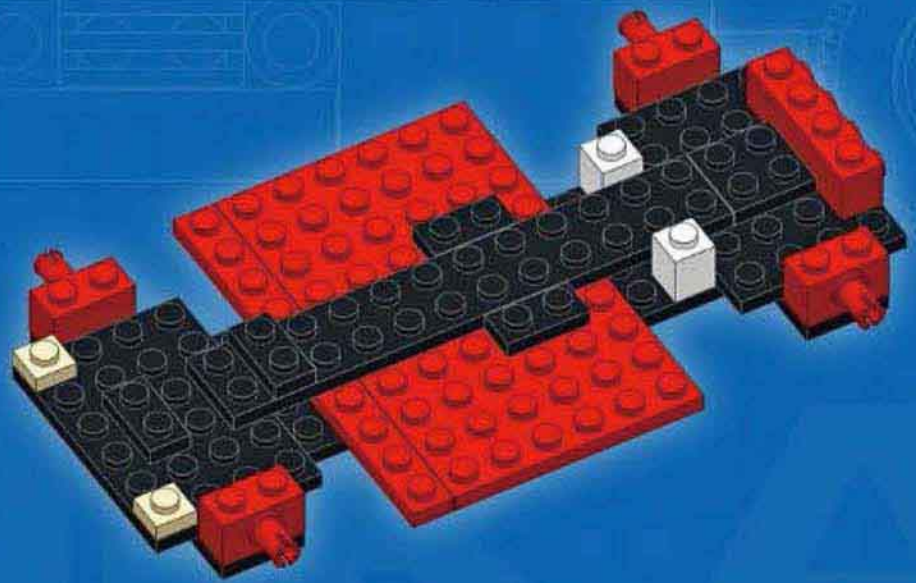
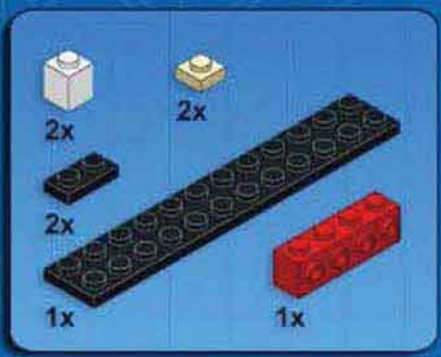

4

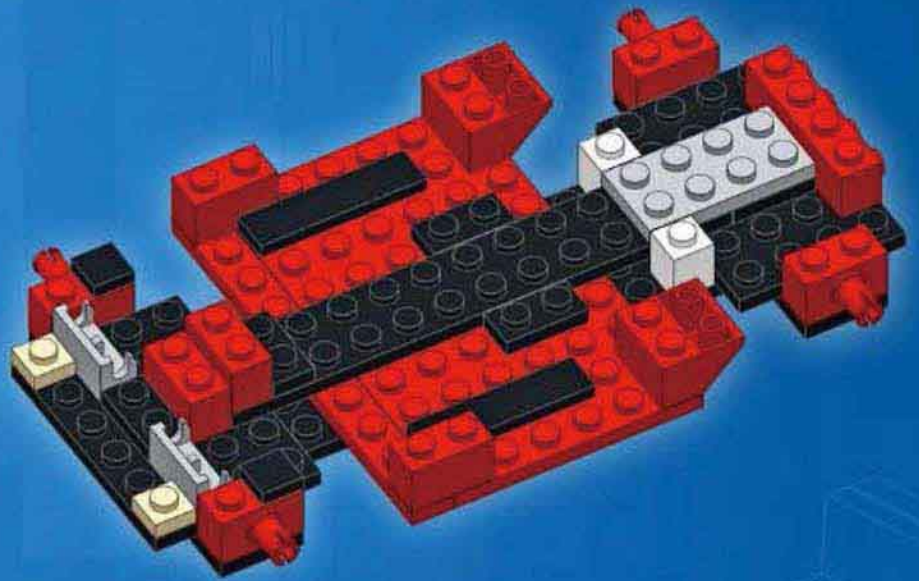

5

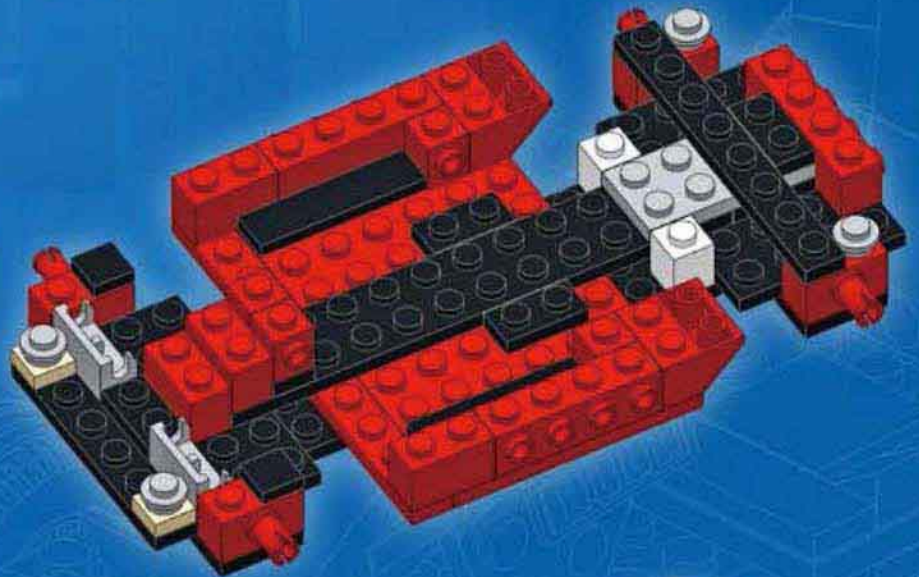
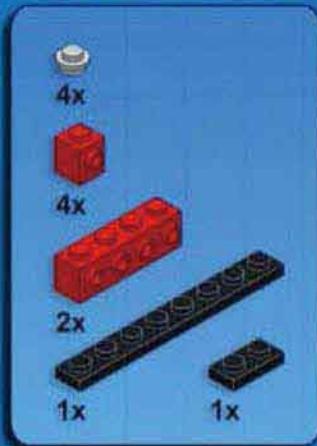

6

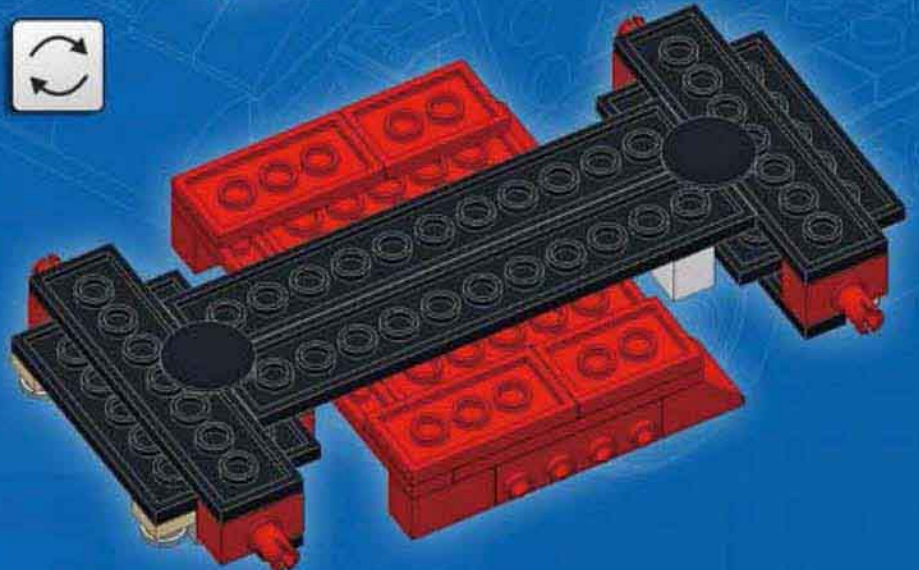
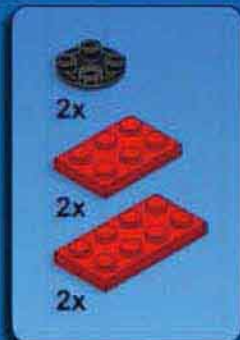

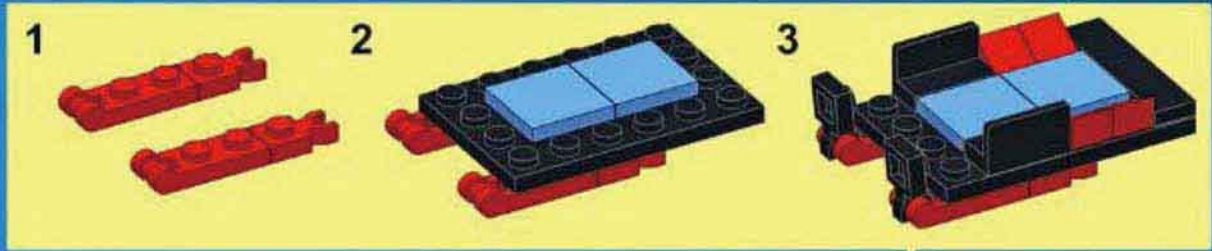

7

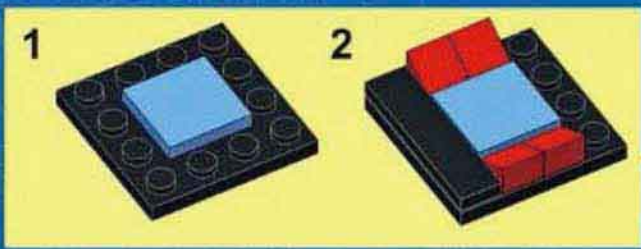
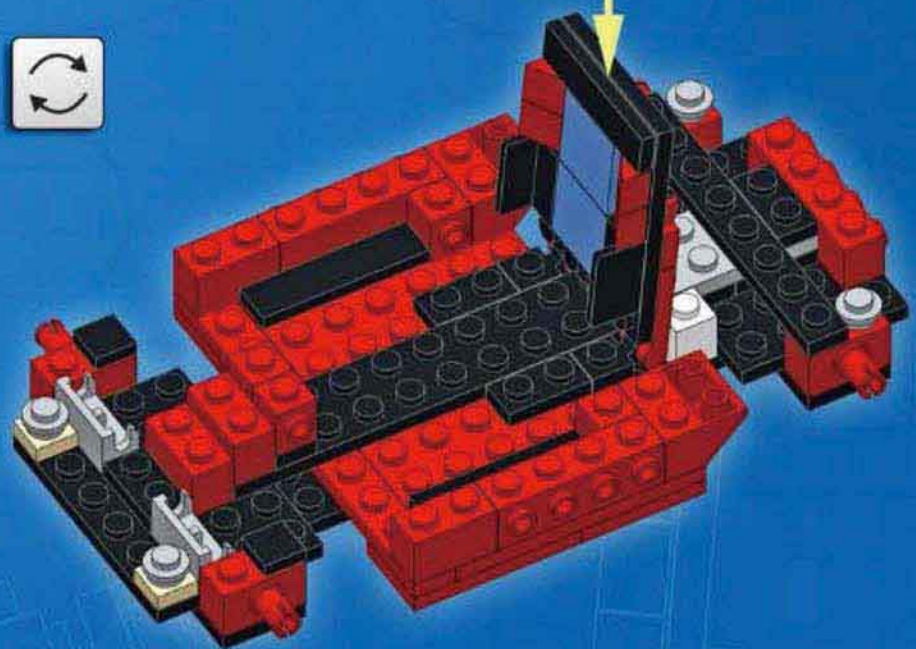
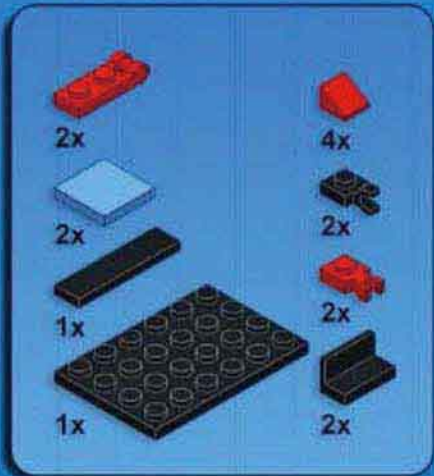

8

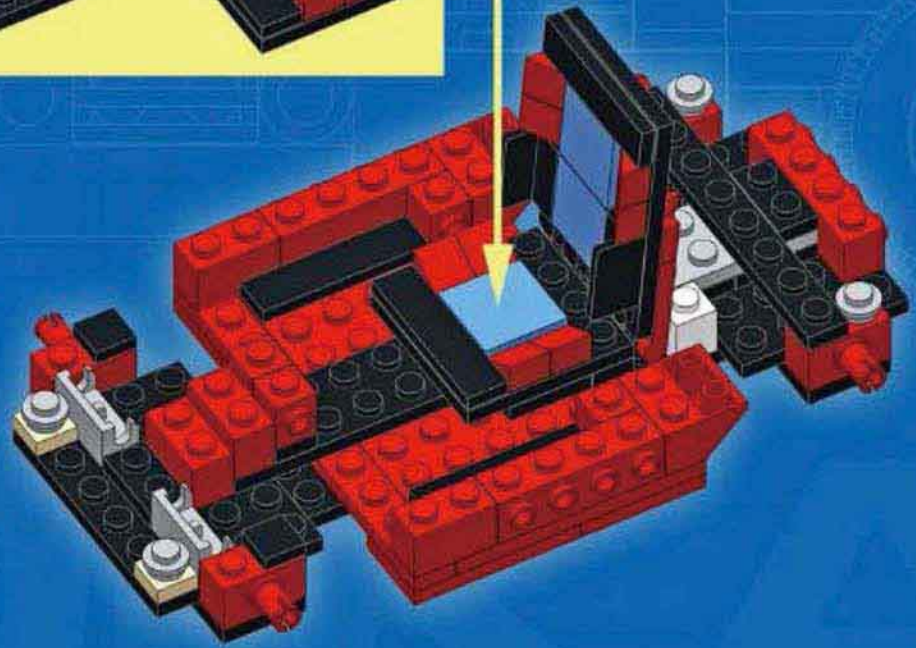
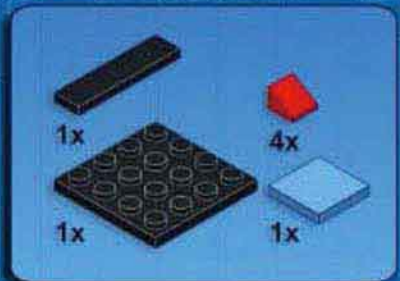

9

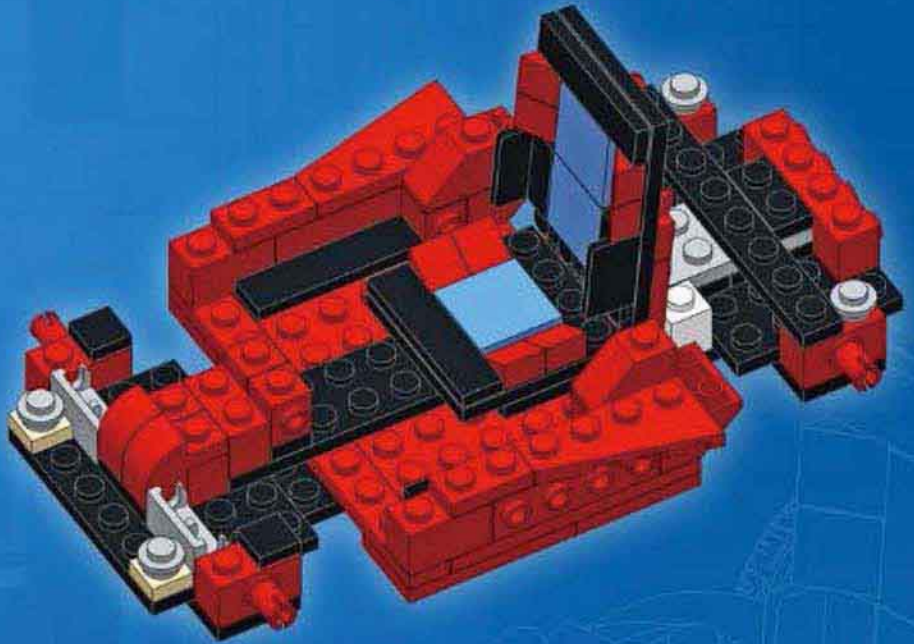
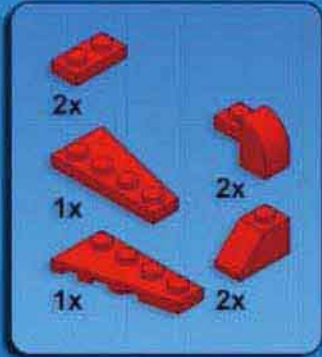

10

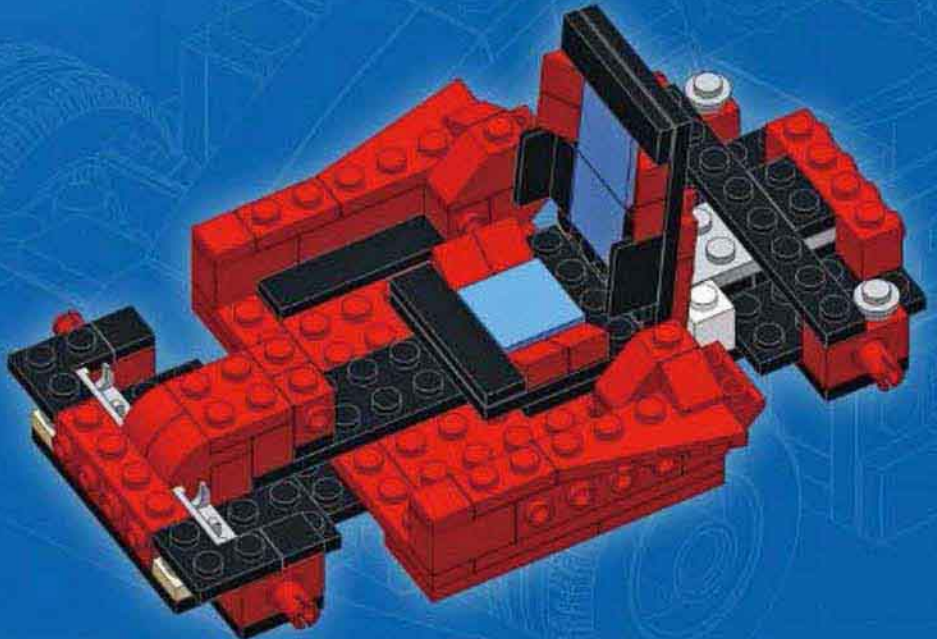
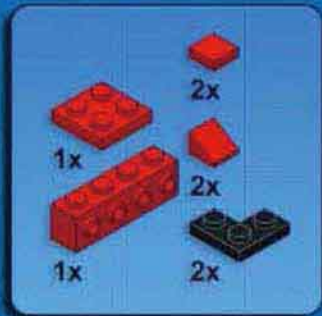



11

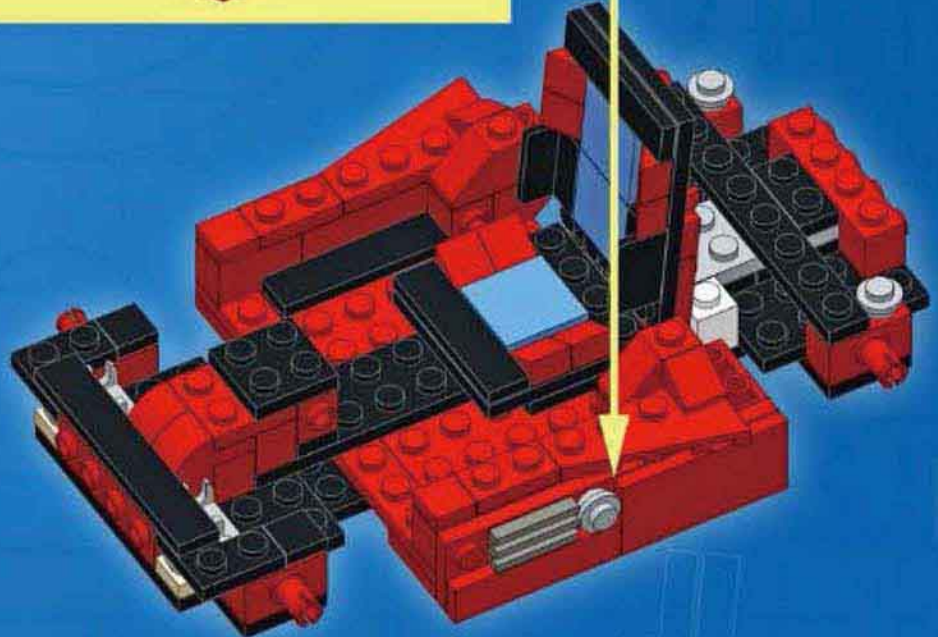
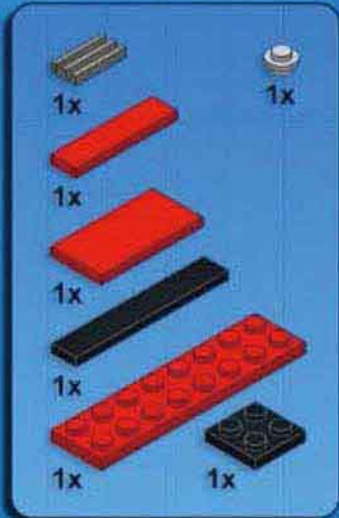
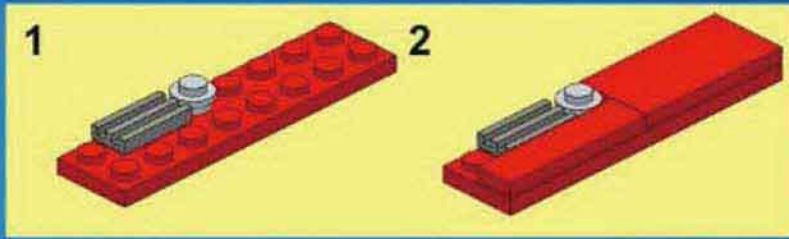

12

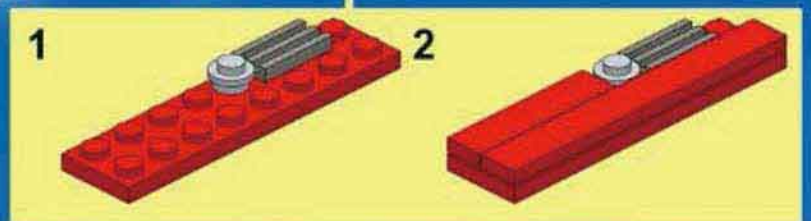
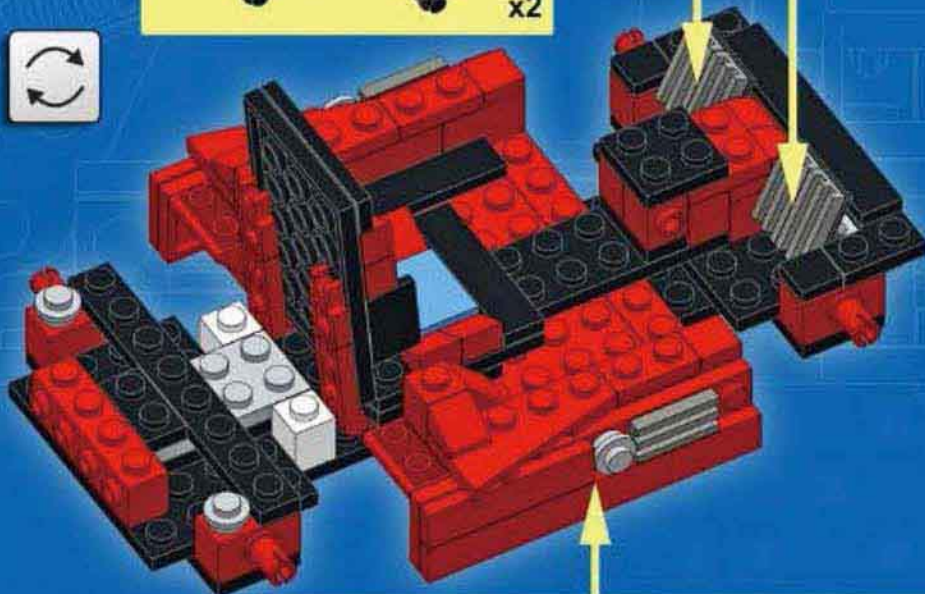
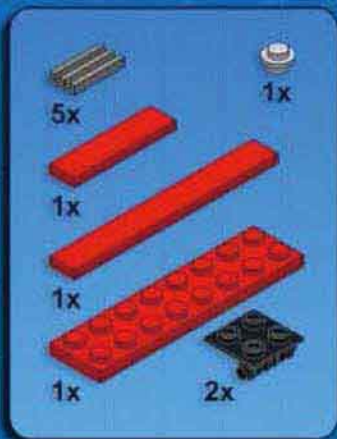



13

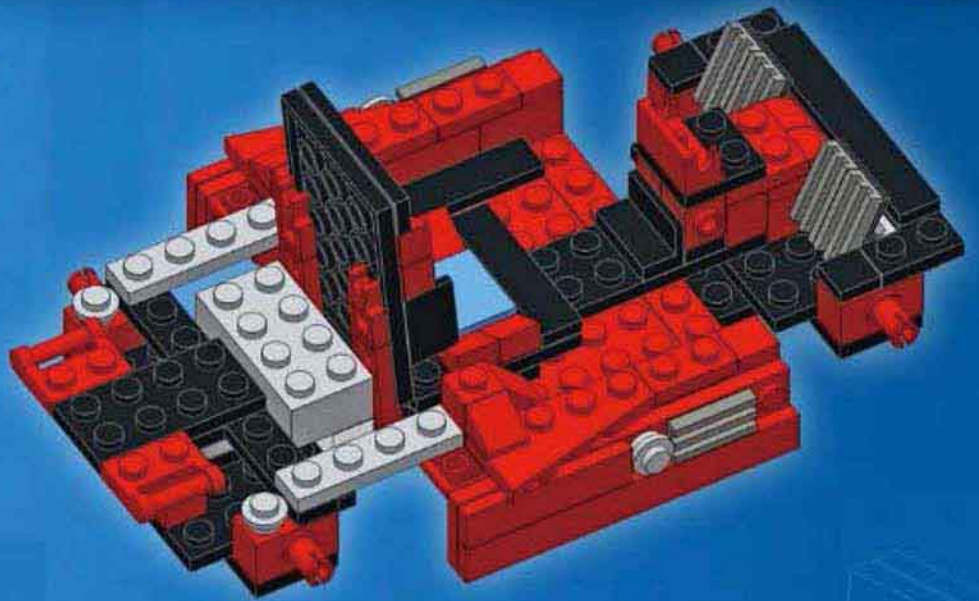
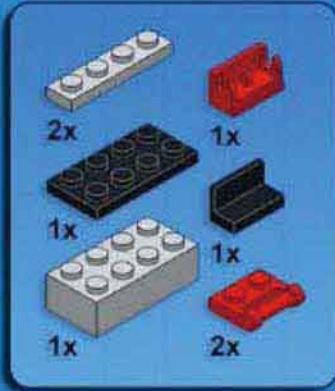

14

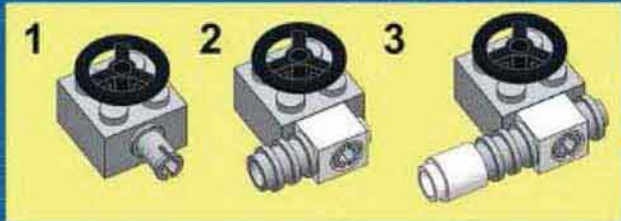
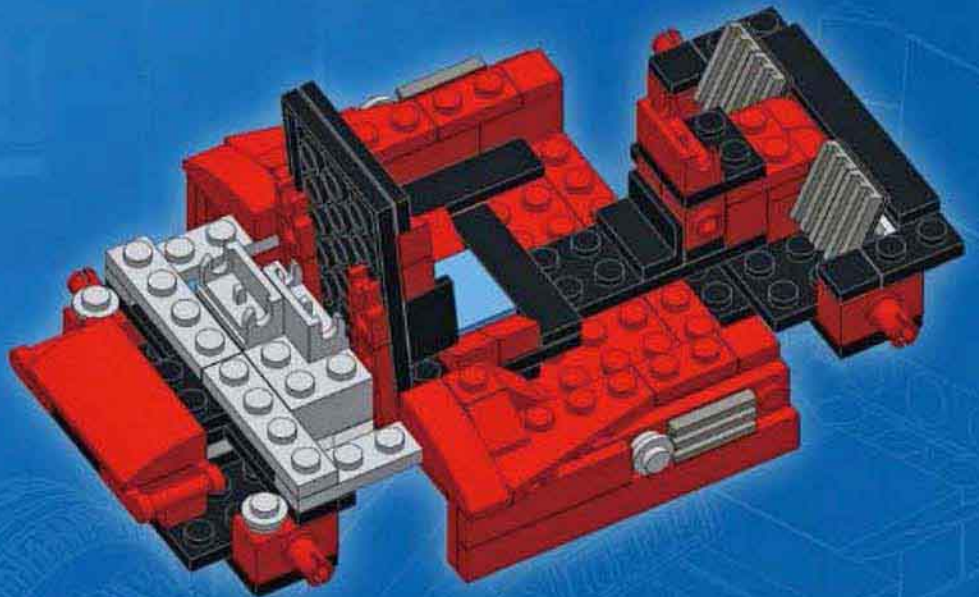
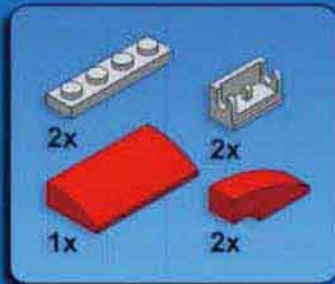

15

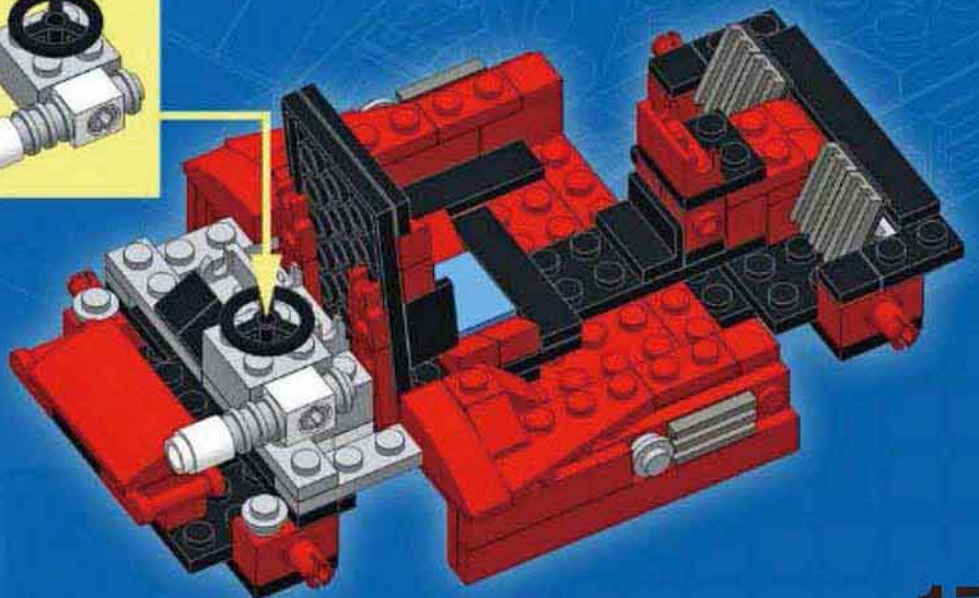



16

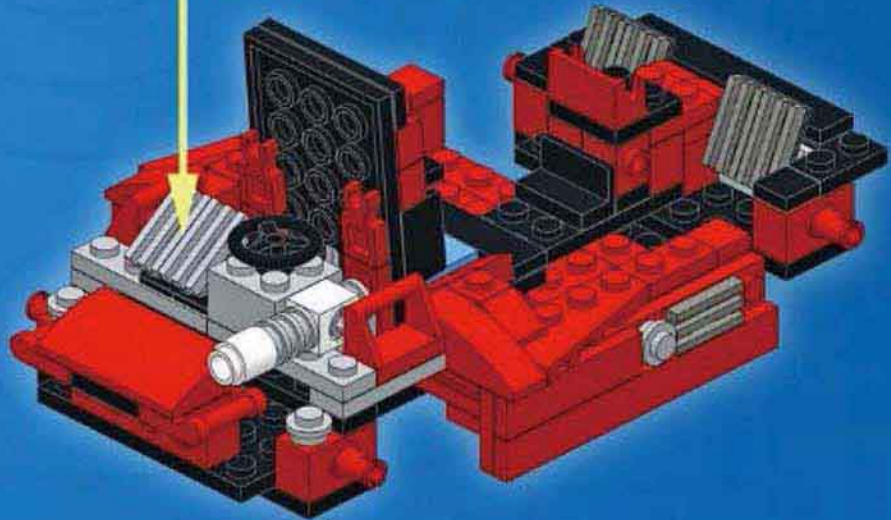

17

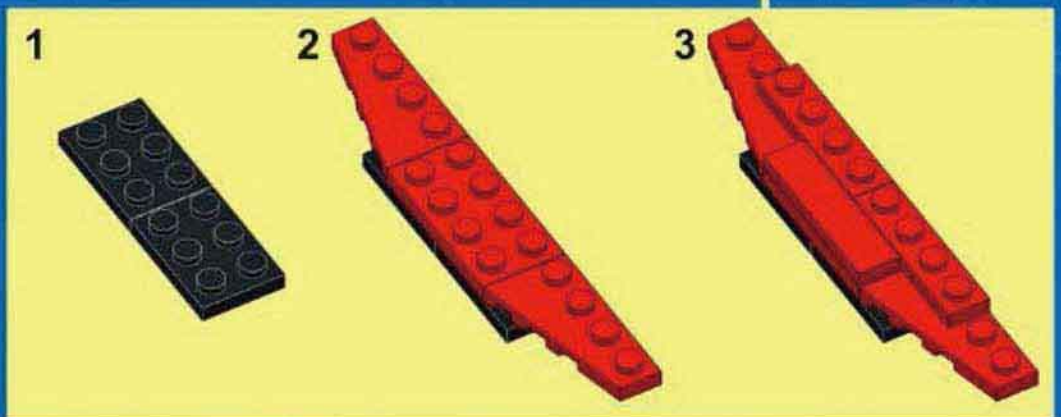
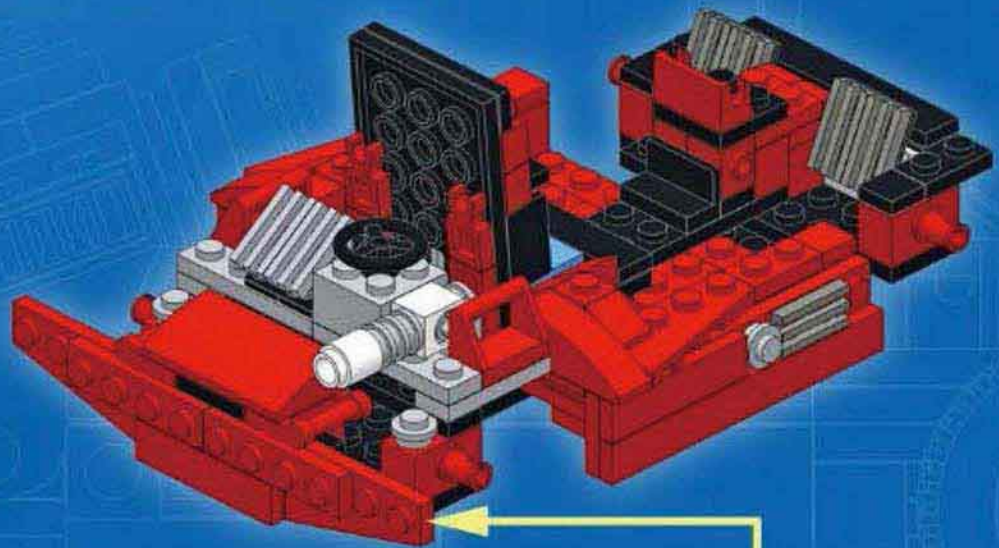
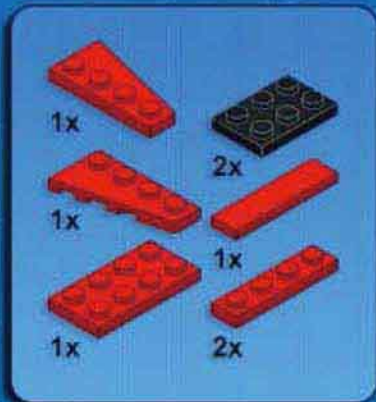



18

- 1x [Black 2x2 Technic Plate]
- 2x [Black 2x2 Technic Plate]
- 3x [White Technic Pin]
- 1x [Red 1x3 Technic Beam]
- 1x [Red 1x2 Technic Beam]
- 1x [Grey Technic Axle]
- 1x [Red 1x3 Technic Beam]
- 1x [Black 2x2 Technic Plate]
- 1x [Black 2x2 Technic Plate]
- 1x [Red 1x3 Technic Beam]
- 2x [Red 1x2 Technic Beam]
- 2x [Black 2x2 Technic Plate]

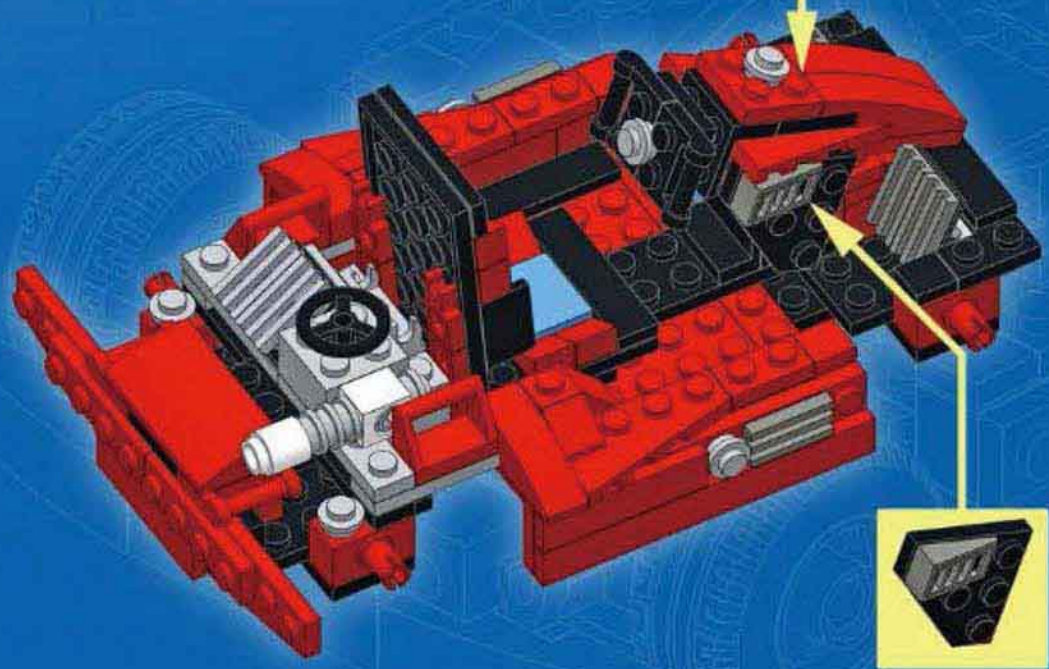
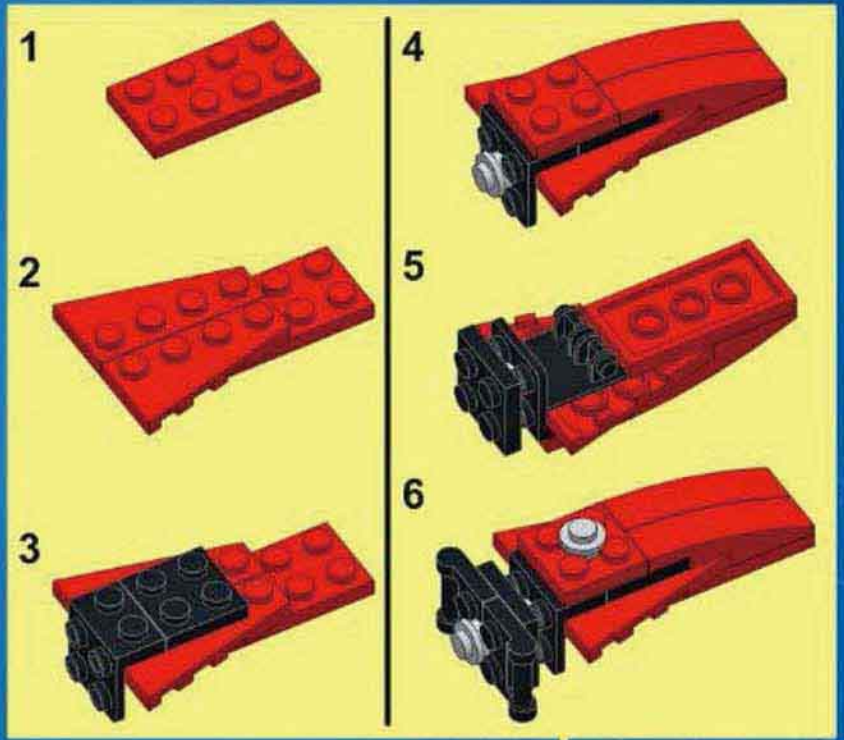



19



- 2x
- 2x
- 2x
- 1x
- 1x

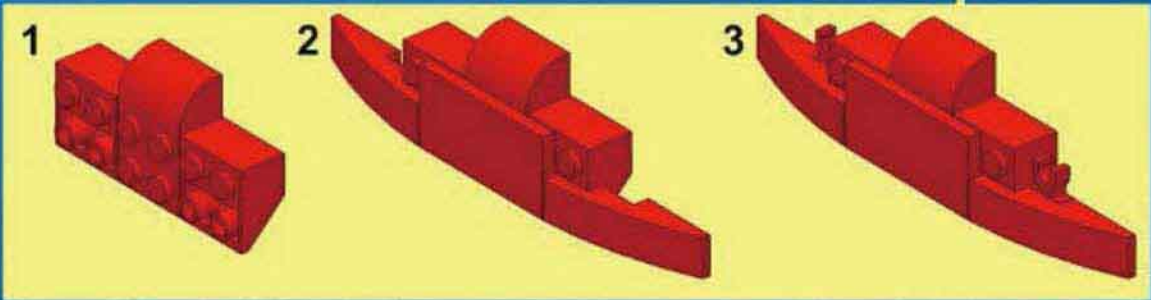
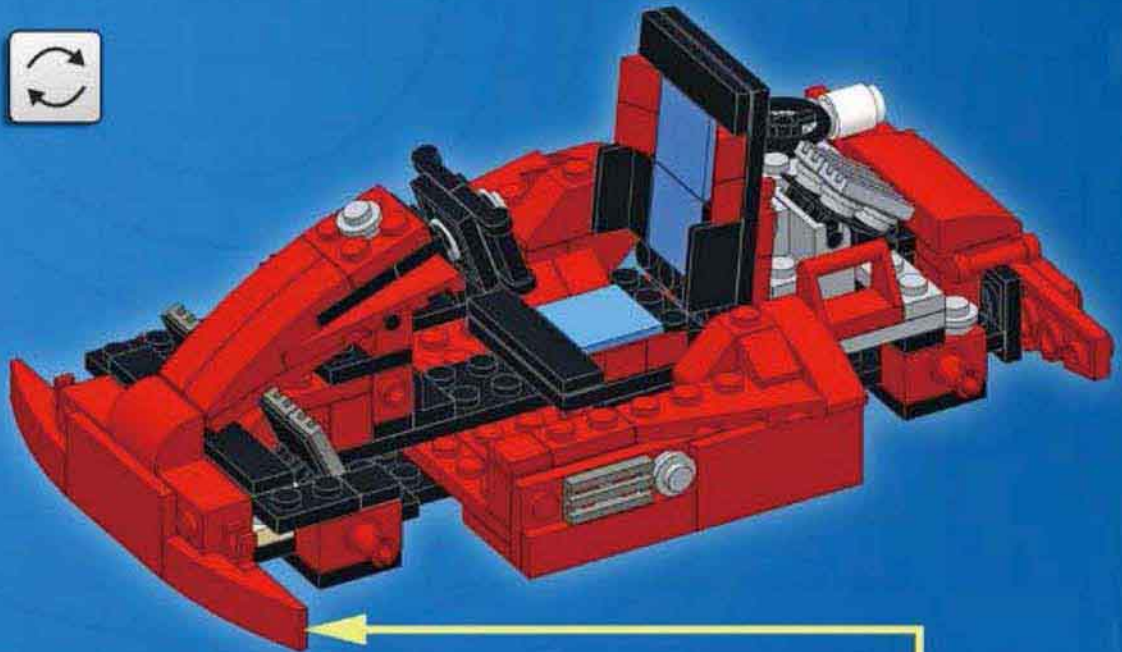

20

- 1x
- 1x
- 4x
- 4x

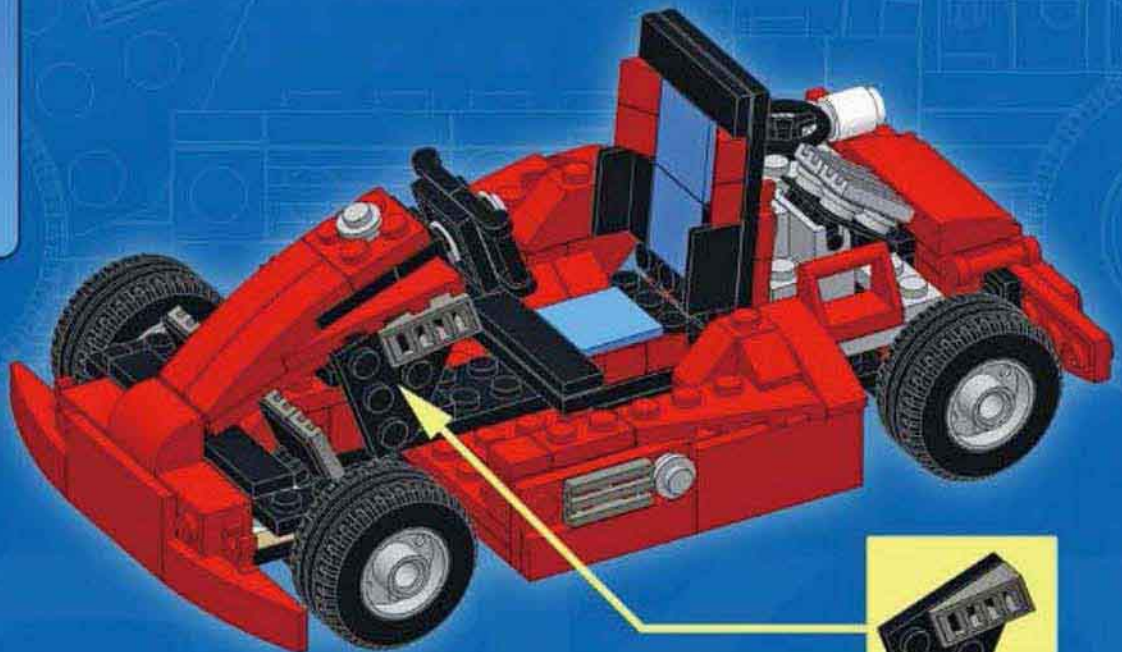



Complexity   
Functions   
Pieces 

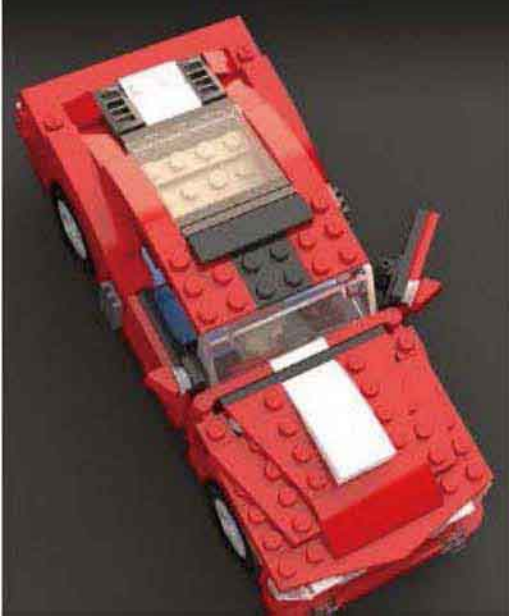
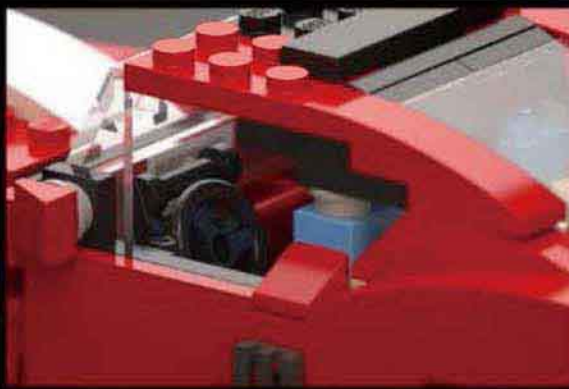

**MUSCLE CAR**

Design notes: fastback body design, hood scoop, exposed exhaust pipes

Technical specifications:  
Dimensions (l x w x h): 21 x 10 x 8 studs  
Wheelbase: 12 studs  
Axle width front/rear: 8/8 studs

Features: opening doors

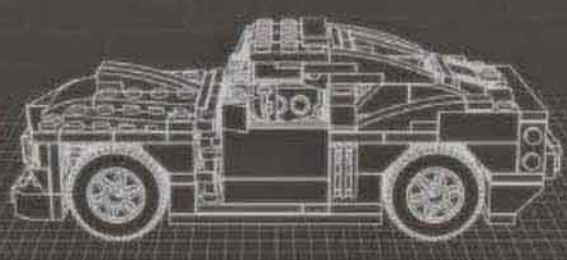



1

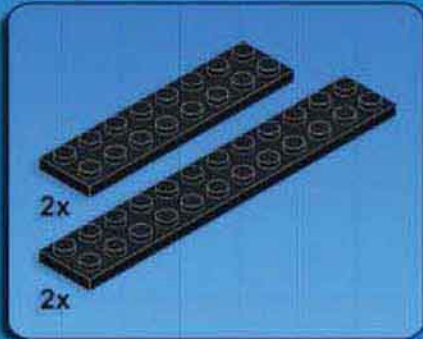

2

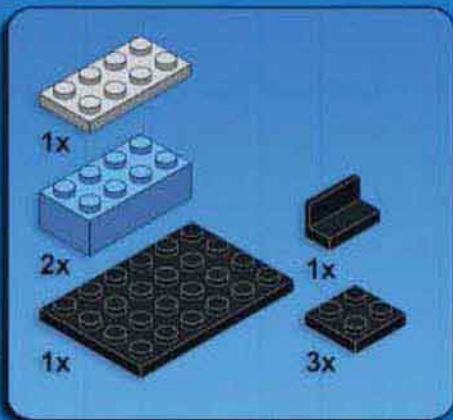

3

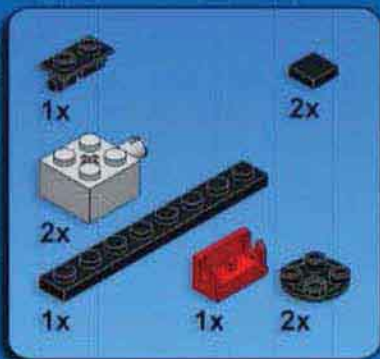

4

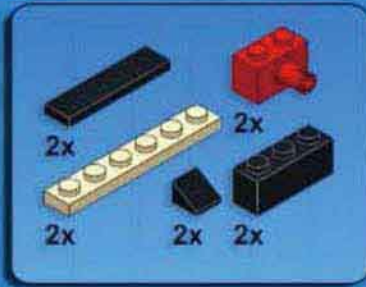

5

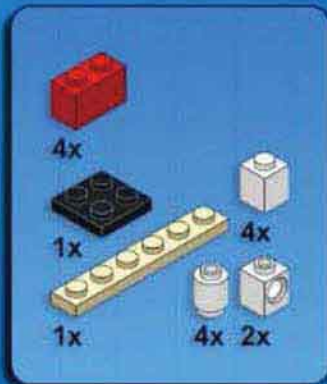

6

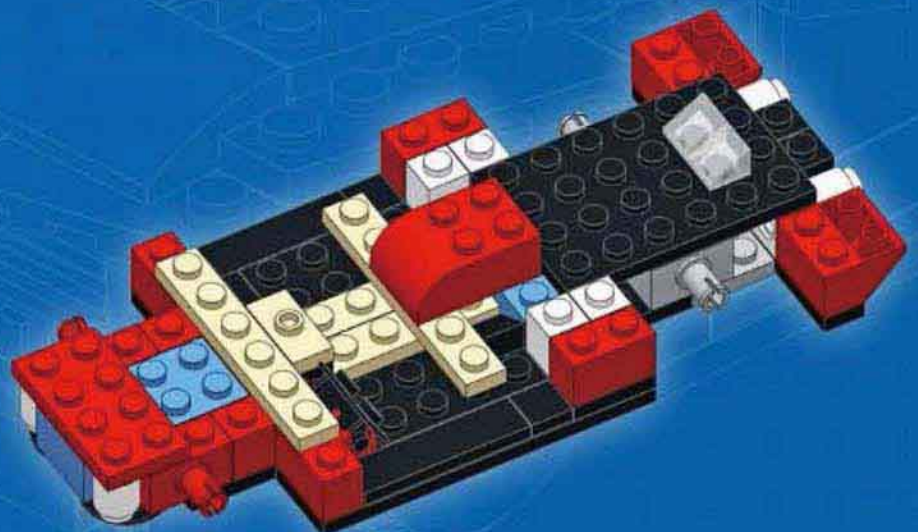
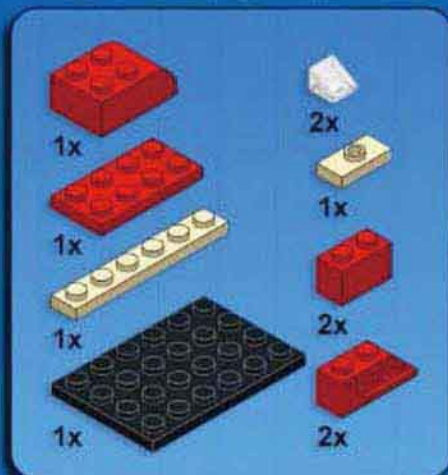



7

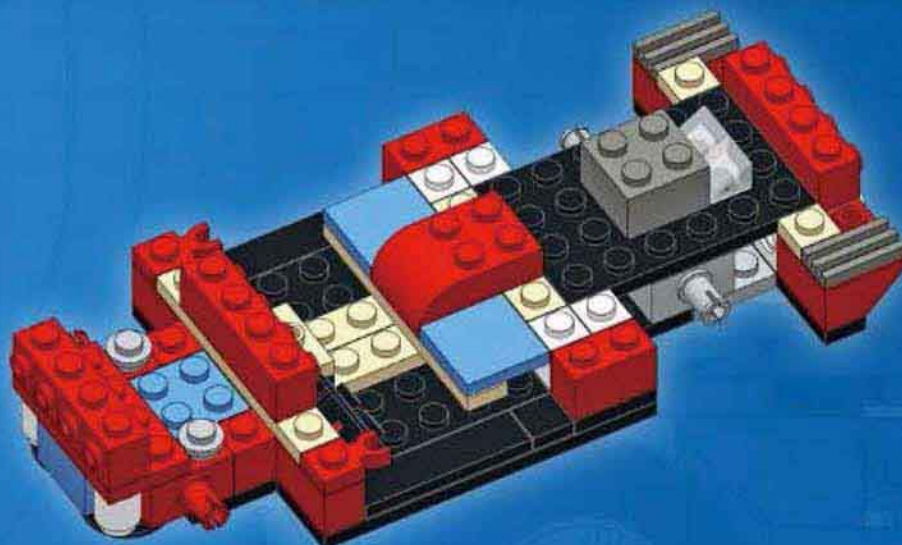
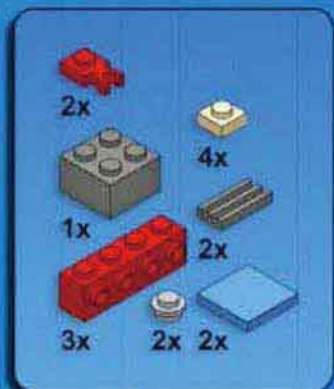

8

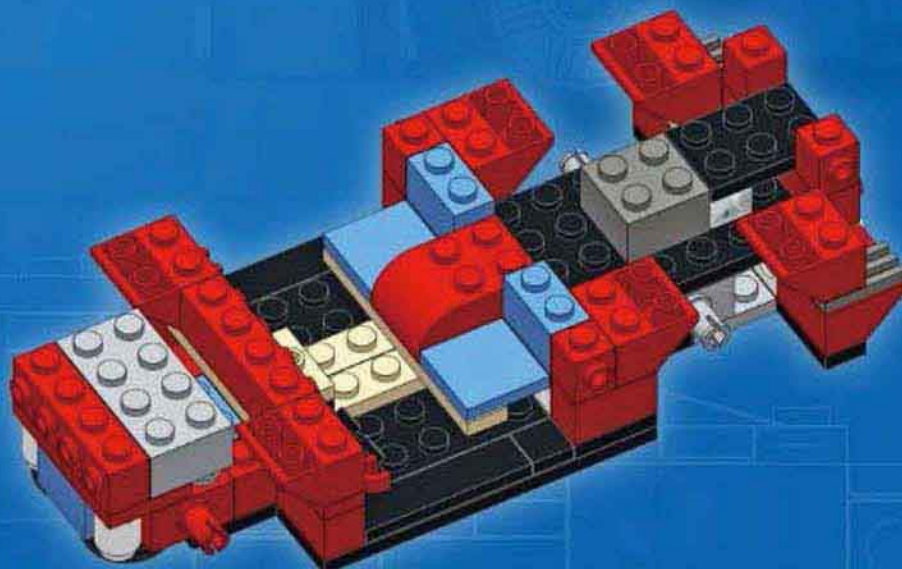
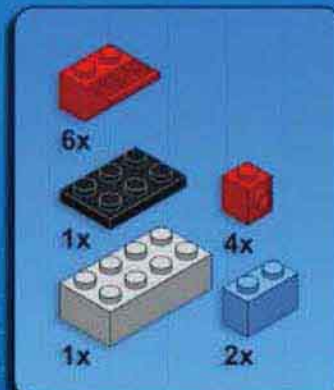

9

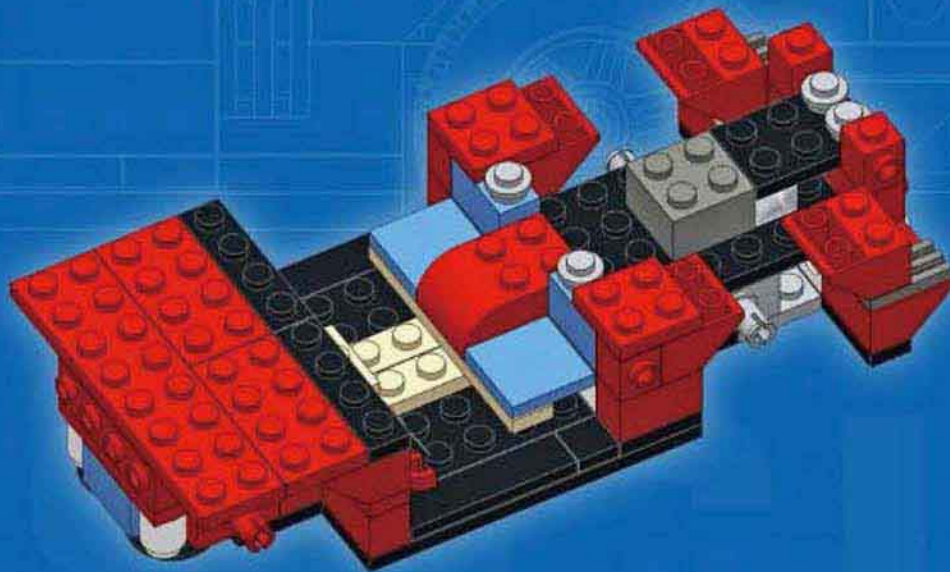
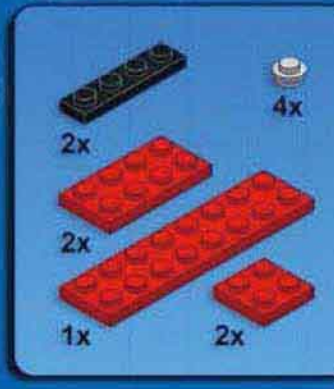



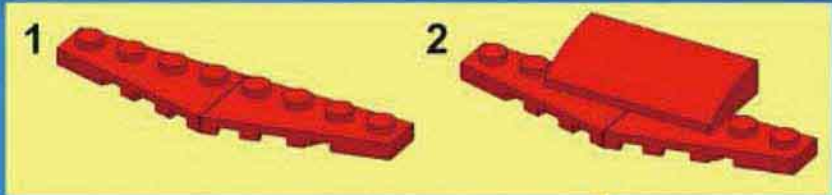

10

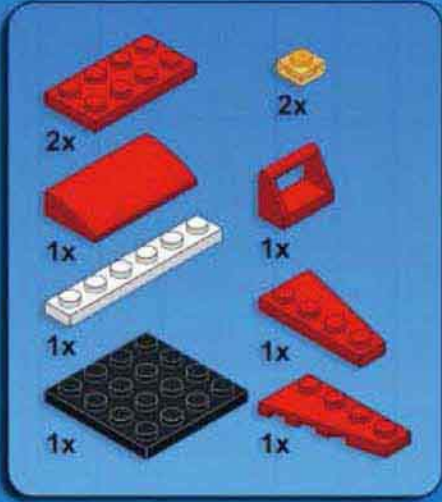

11

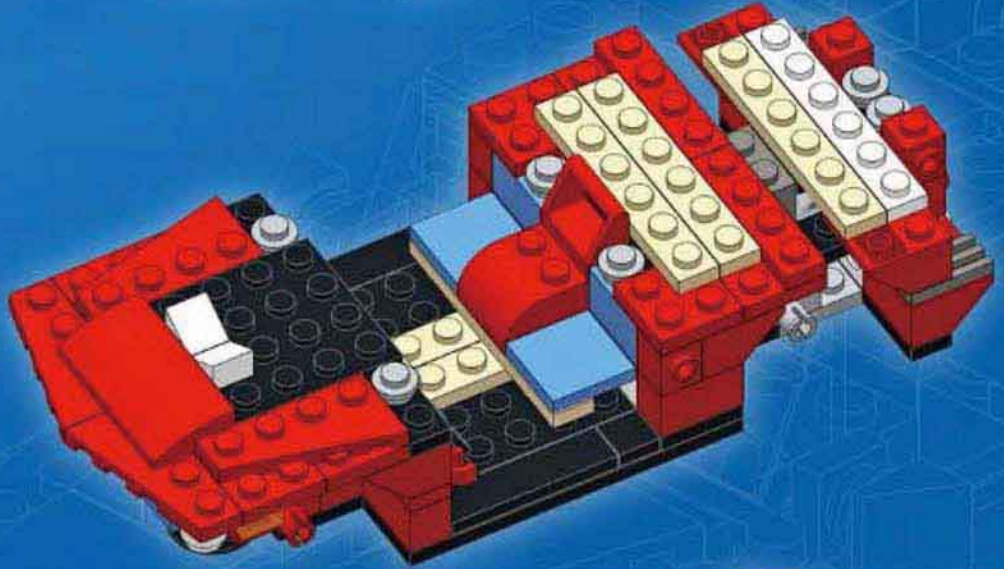
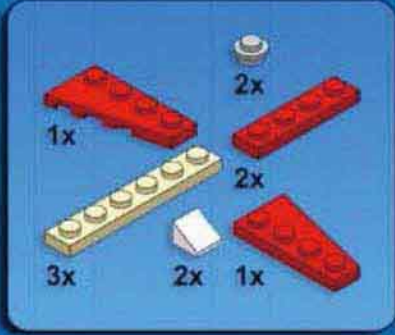

12

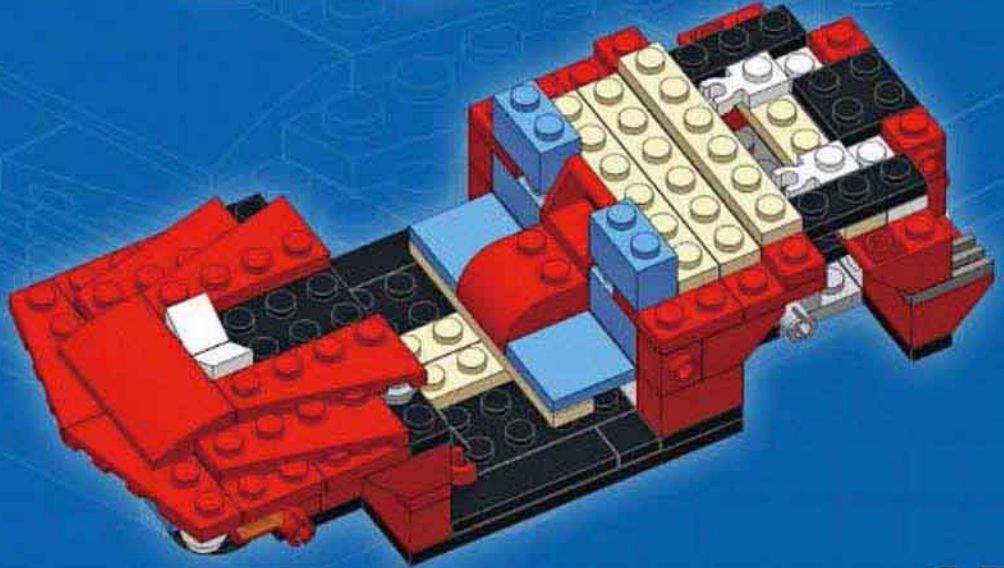
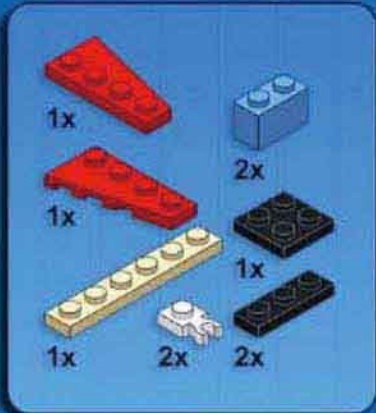



13

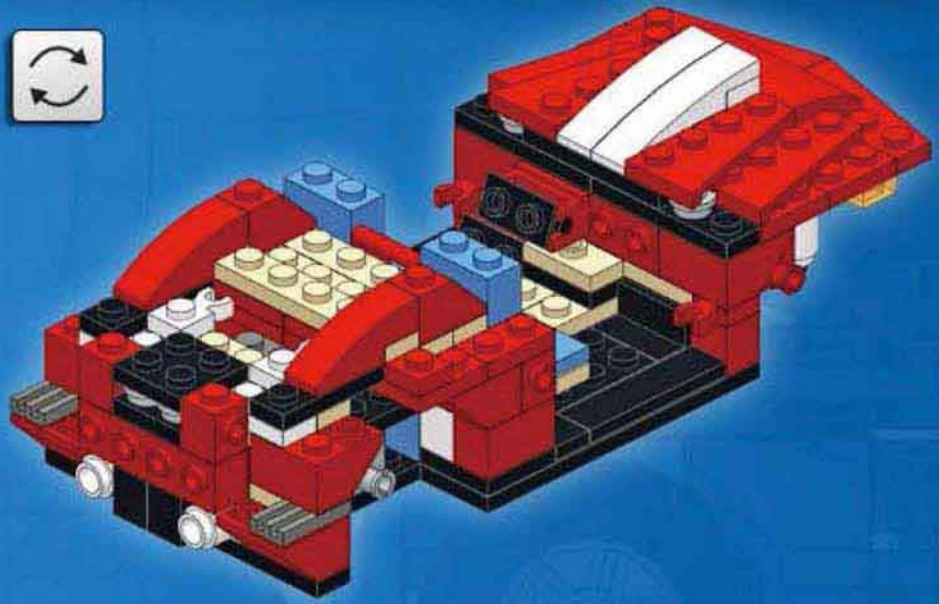
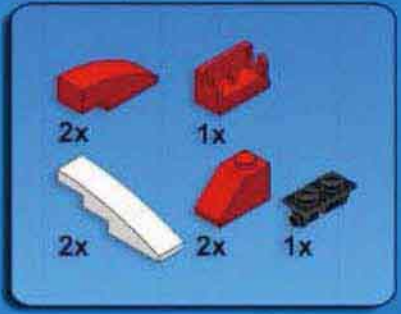

14

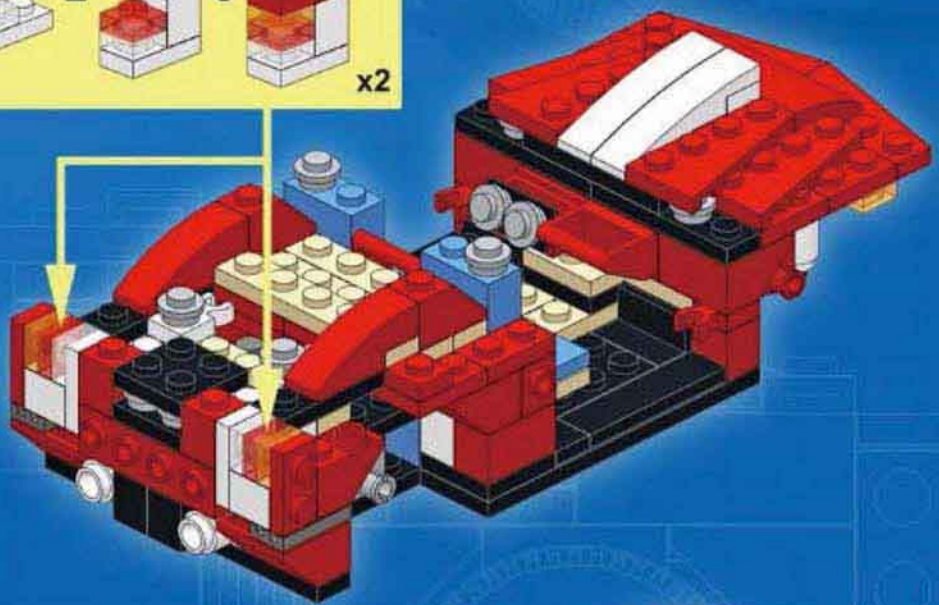
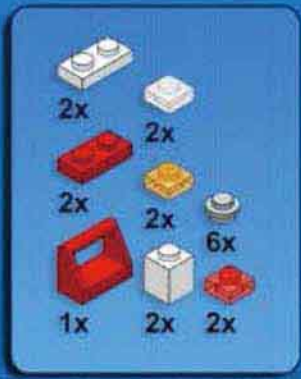
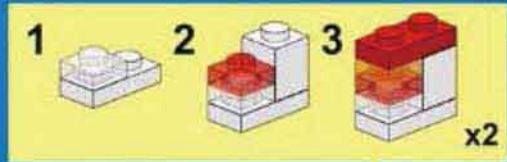

15

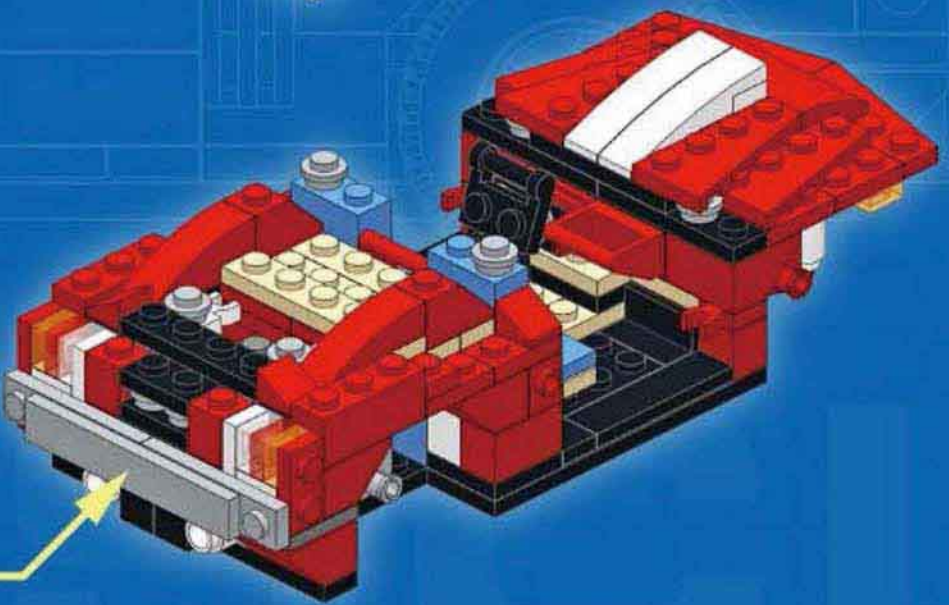
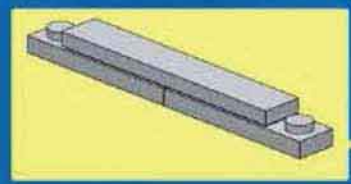
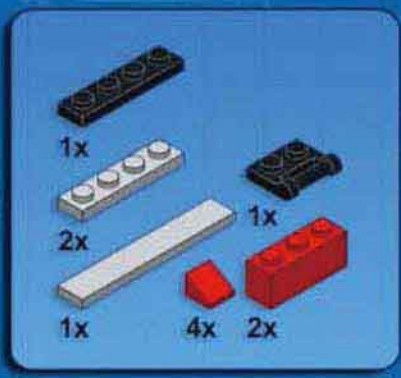



16

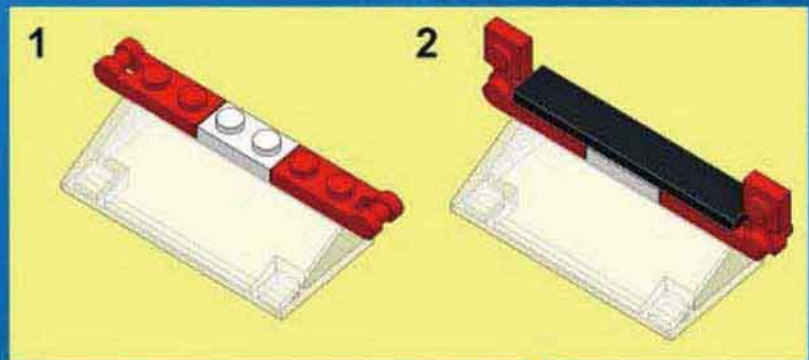
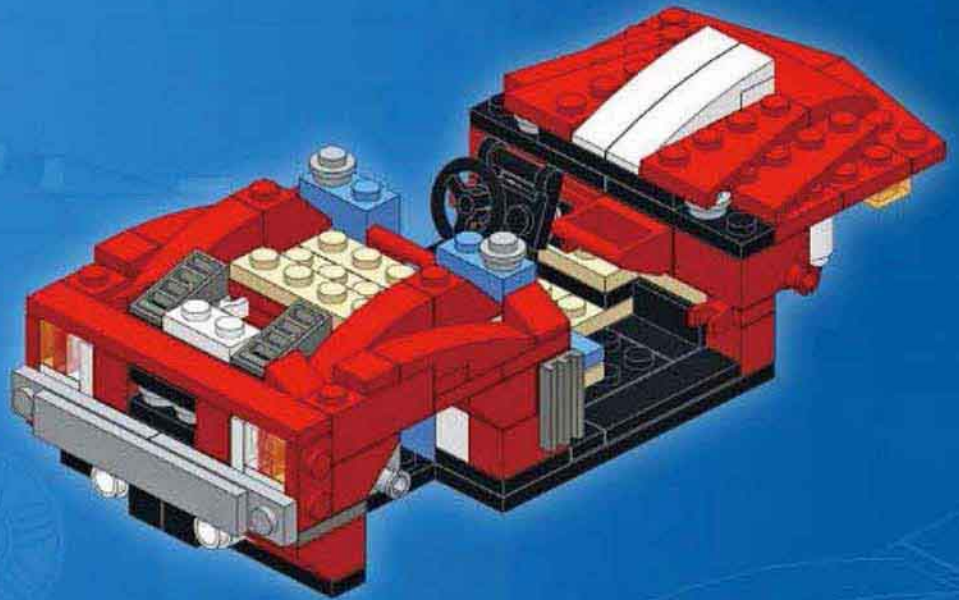
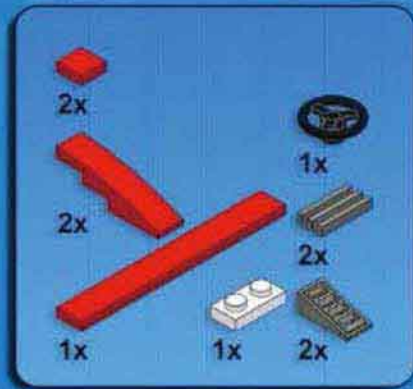

17

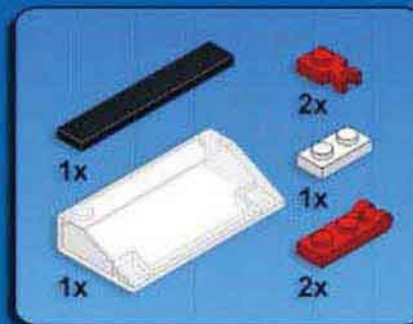

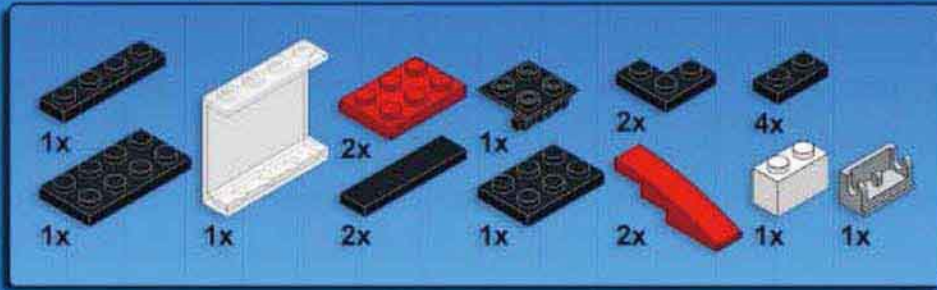

18

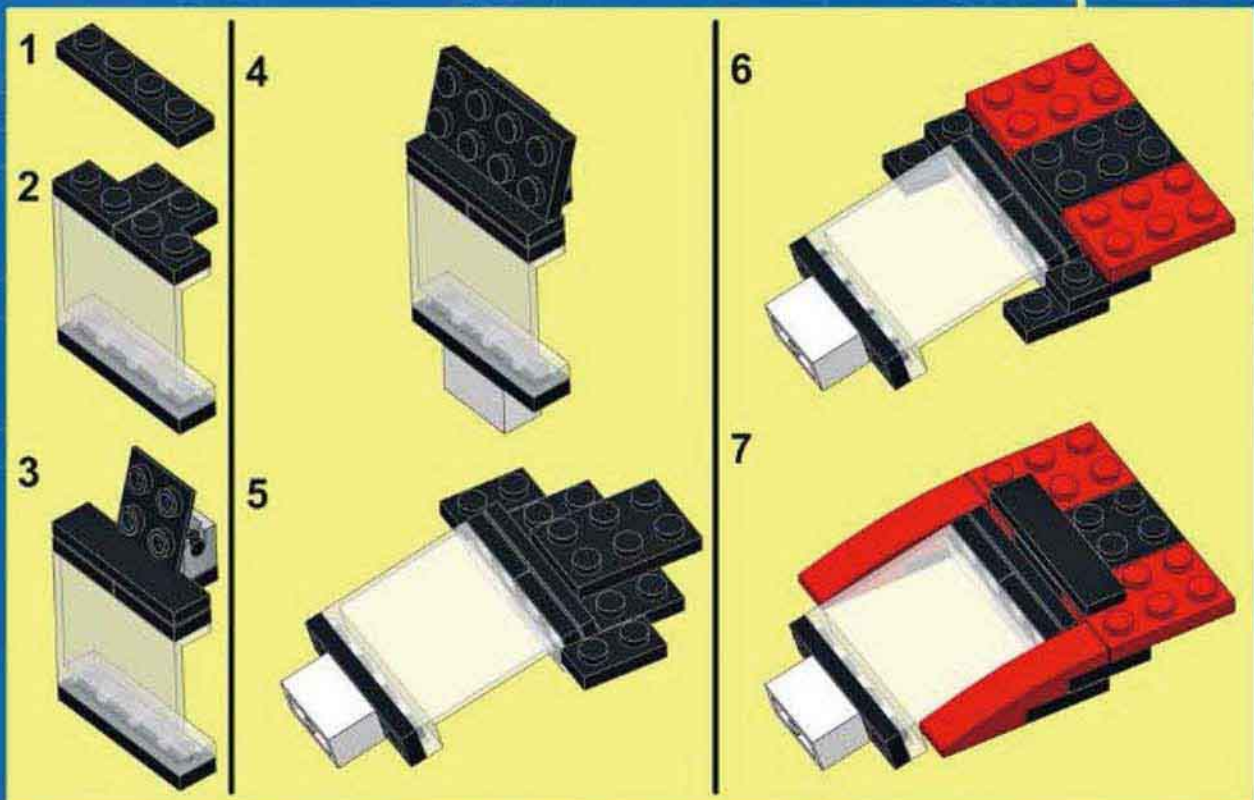
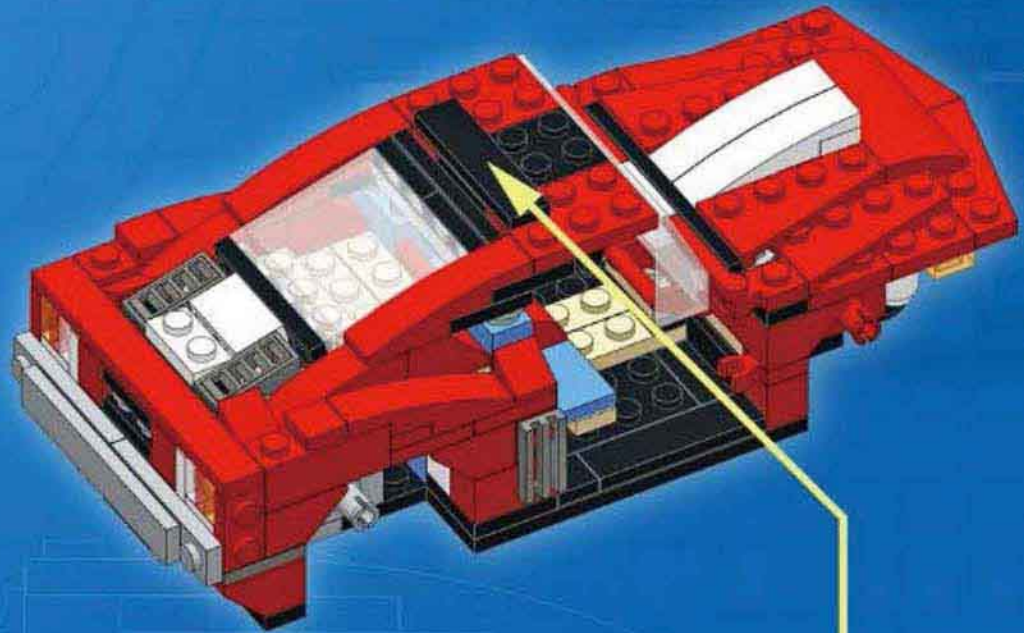



19

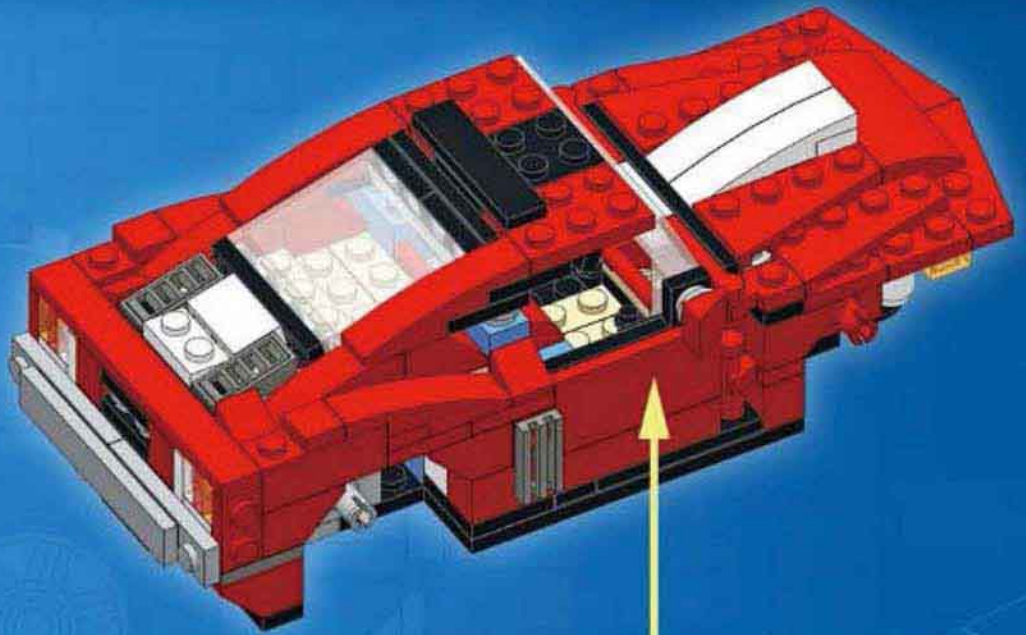
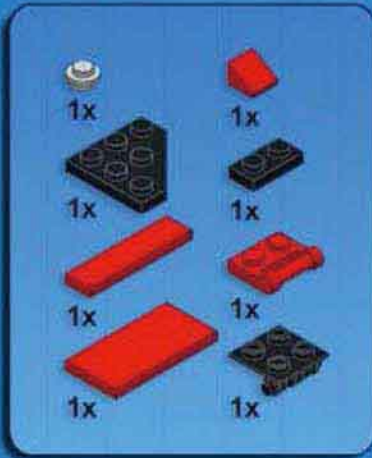

20

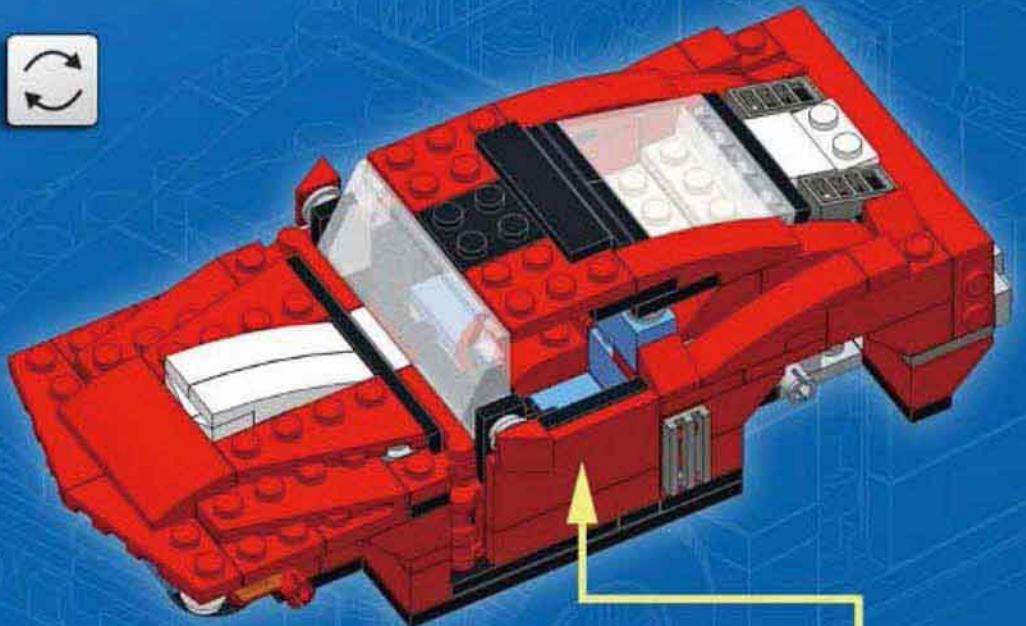
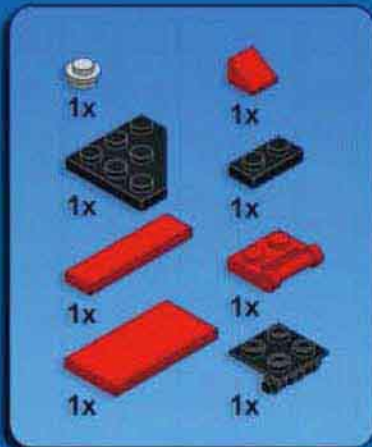





Complexity

Functions

Pieces

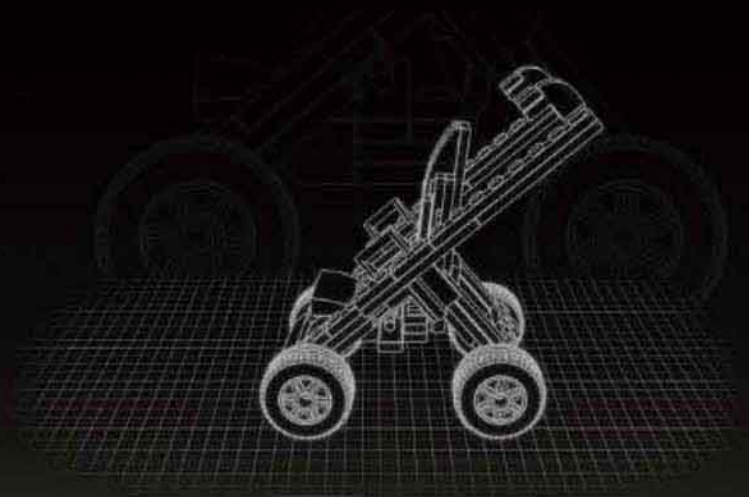

## STROLLER

Design notes: open frame, upright chair, curved handlebars

### Technical specifications:

Dimensions (l × w × h):	14 × 10 × 15 studs
Wheelbase:	8 studs
Axle width front/rear:	10/10 studs



1



1

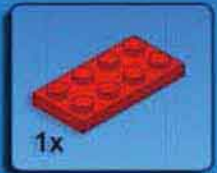

2

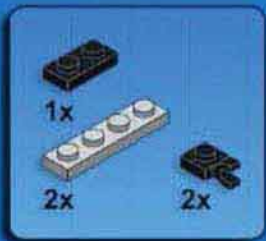

3

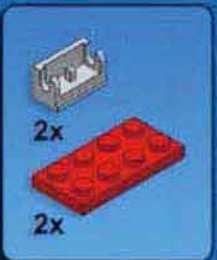

4

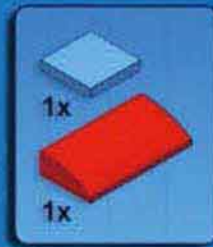
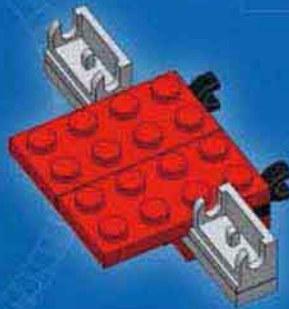

5

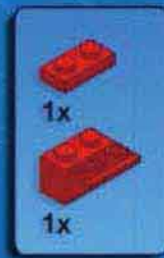
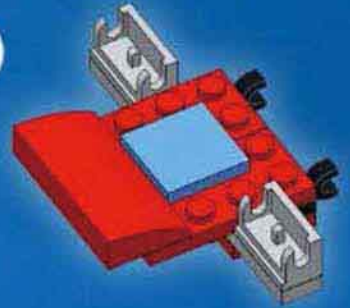

6

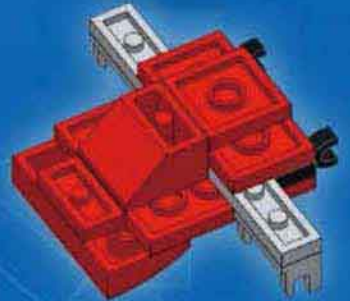

7

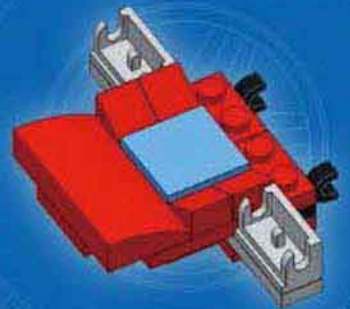



2

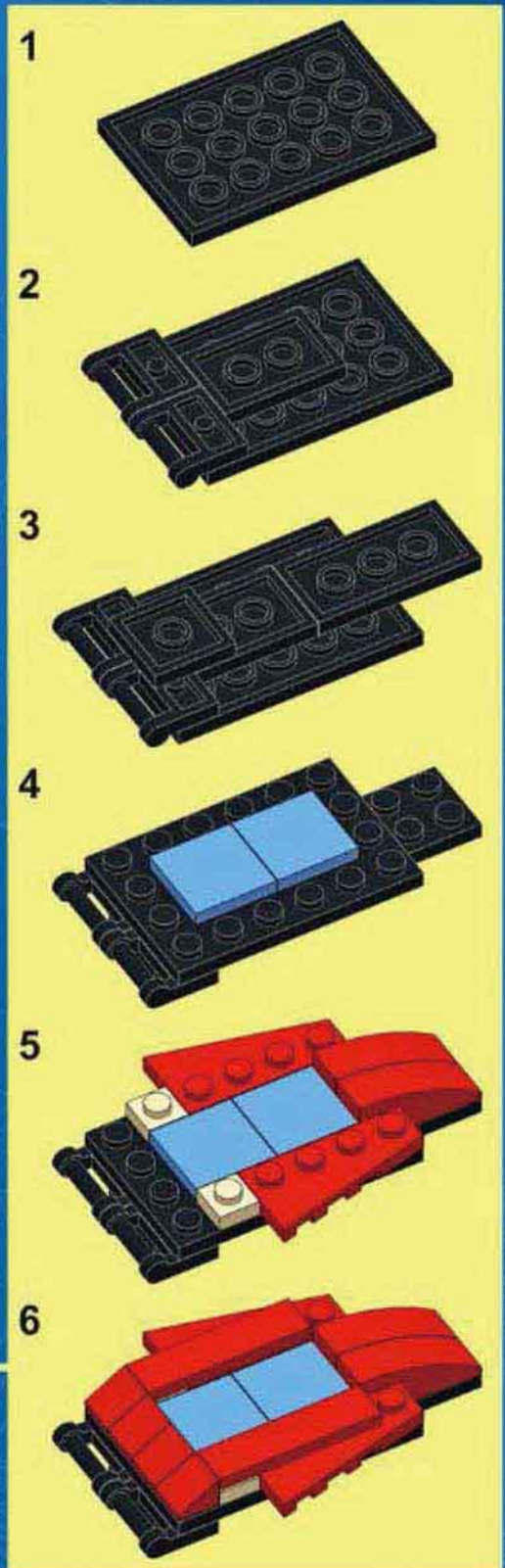
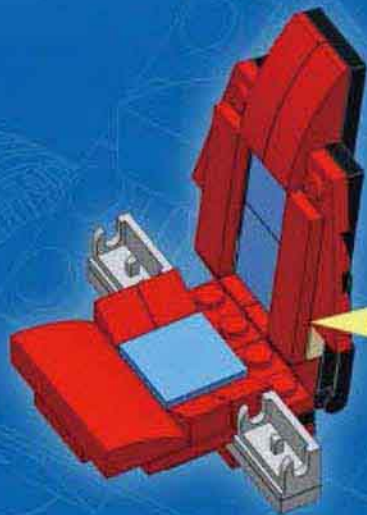
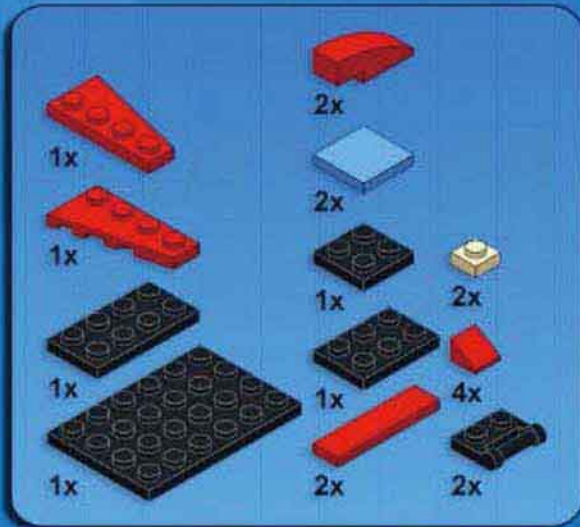



3

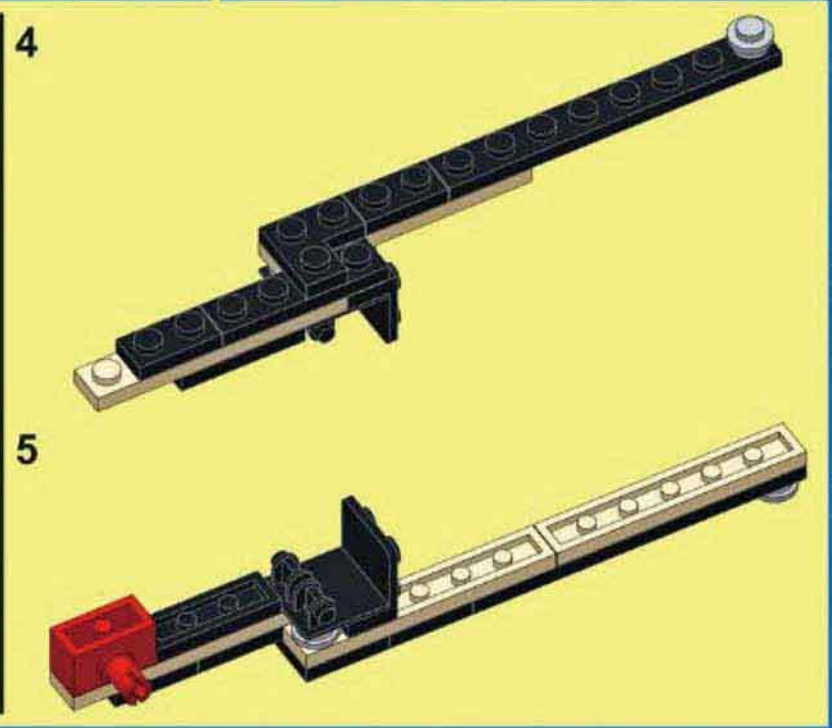
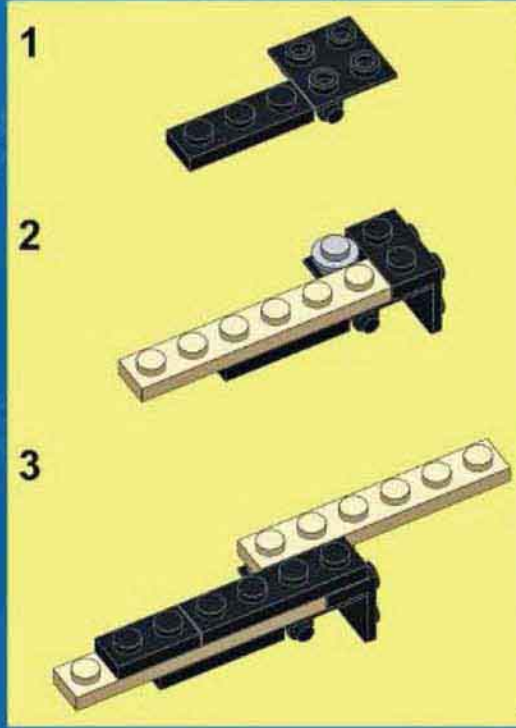
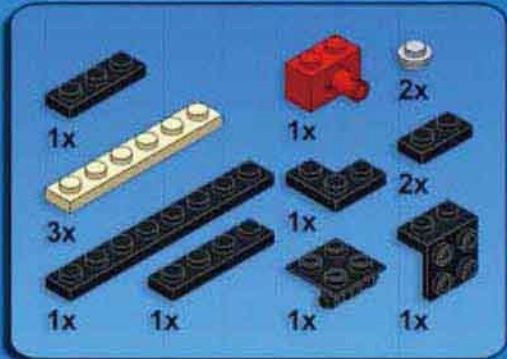

4

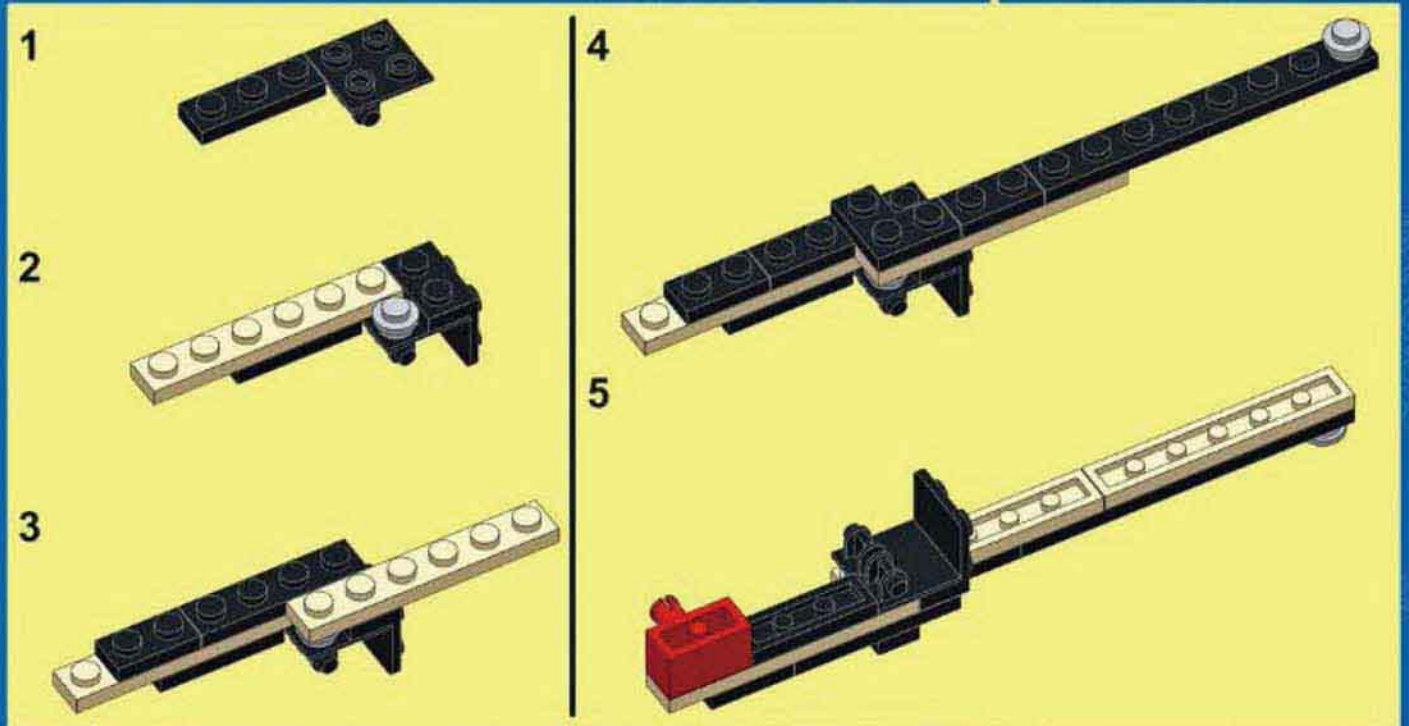
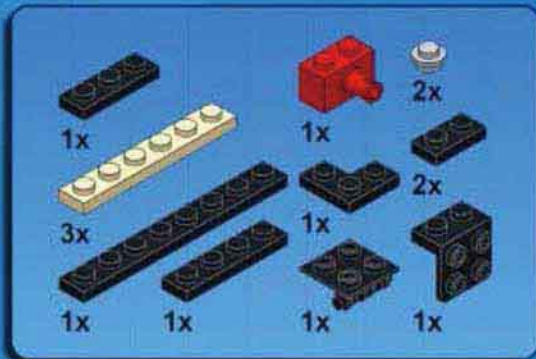



5

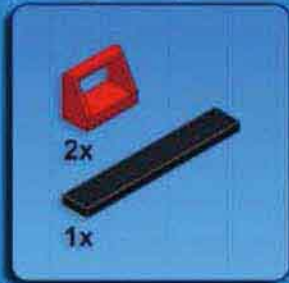

6

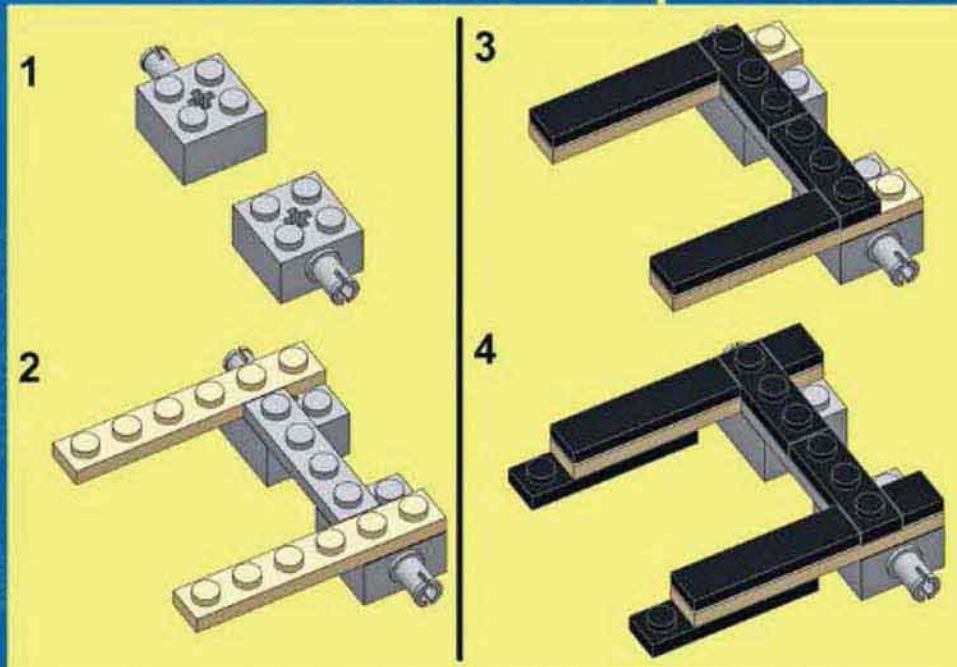
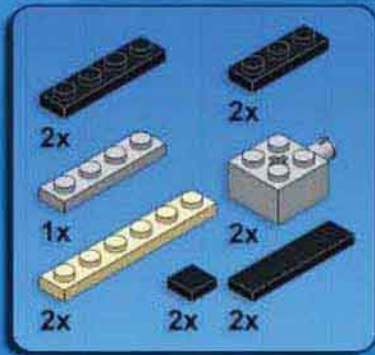



7



8

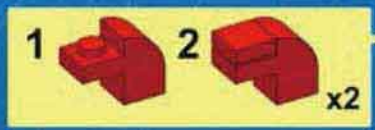

# 05 MULTI-PURPOSE TRUCK



Complexity   
Functions   
Pieces 

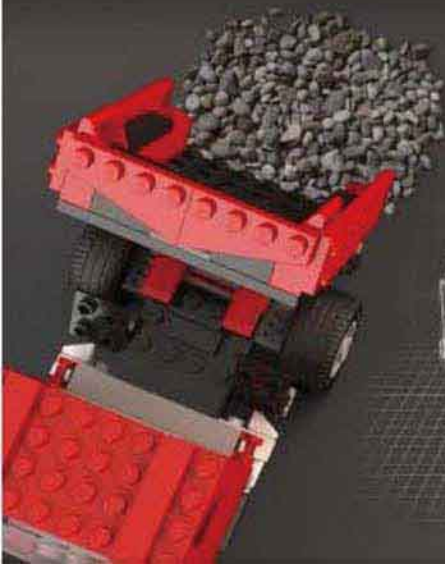

## MULTI-PURPOSE TRUCK

Design notes: short nose, wide axle, high clearance

### Technical specifications:

Dimensions (l × w × h): 19 × 11 × 11 studs  
Wheelbase: 11 studs  
Axle width front/rear: 10/10 studs

Features: tipping bed



1

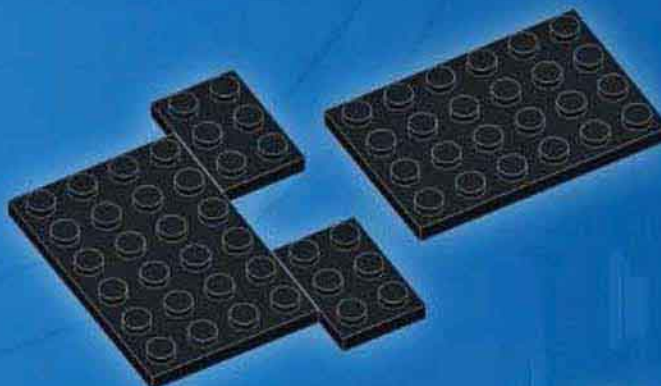
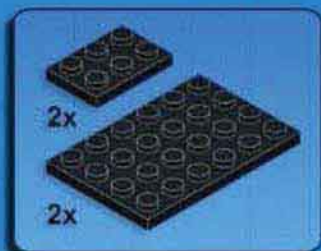

2

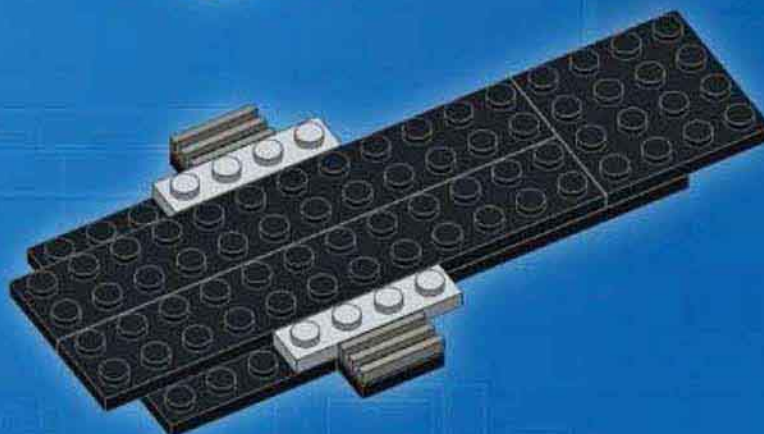
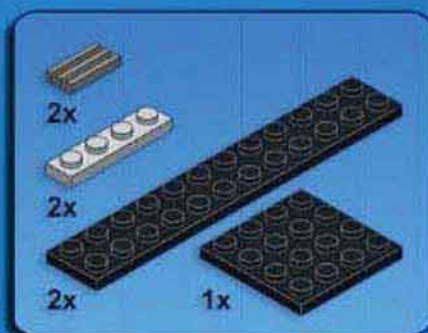

3



4

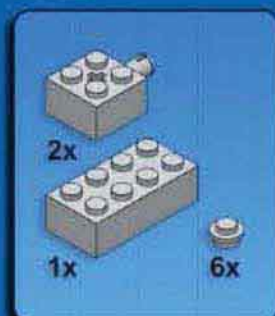



5

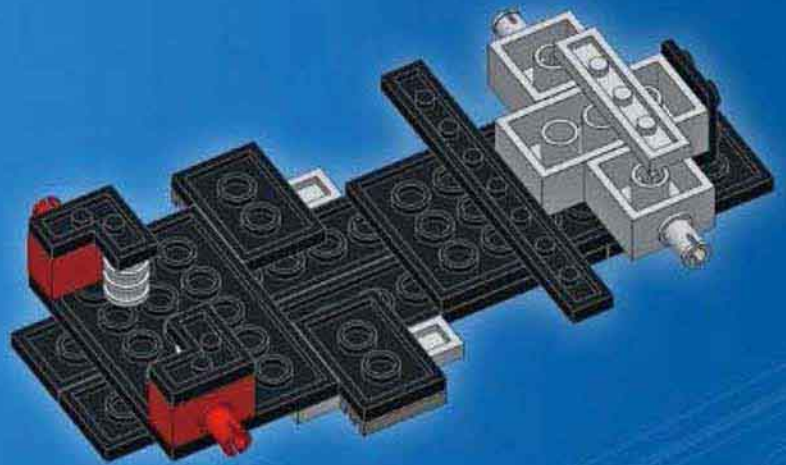
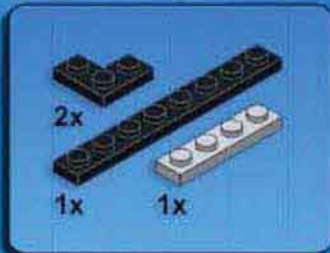

6

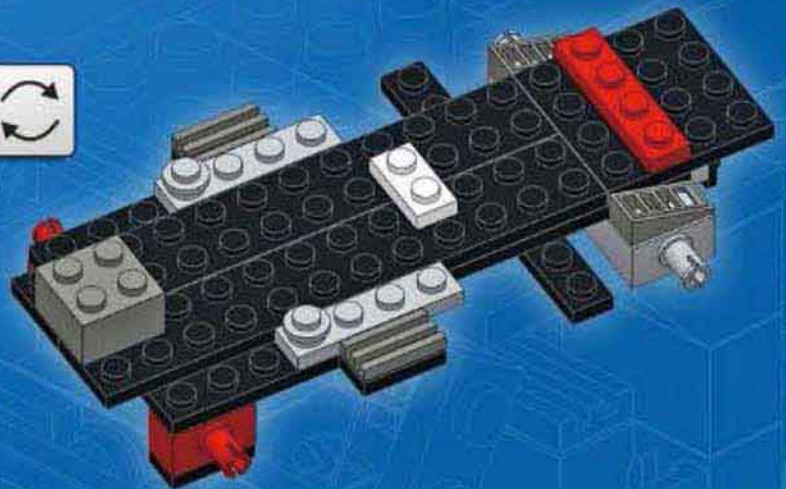
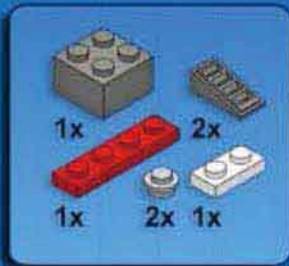

7

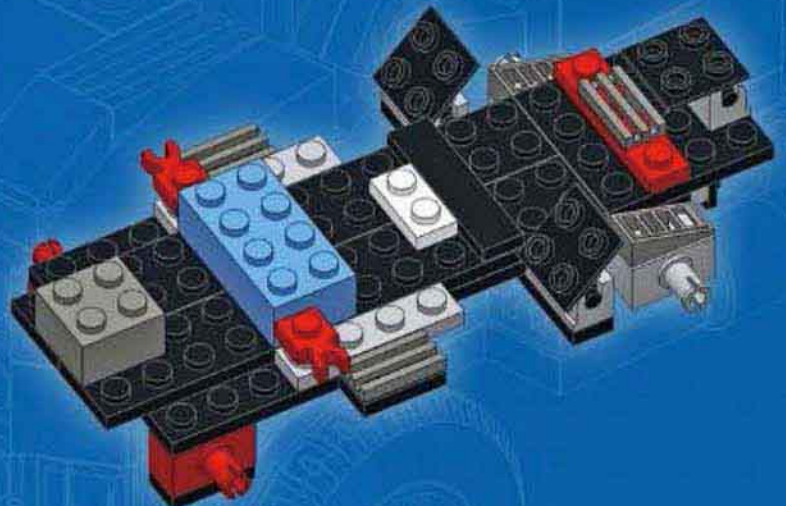
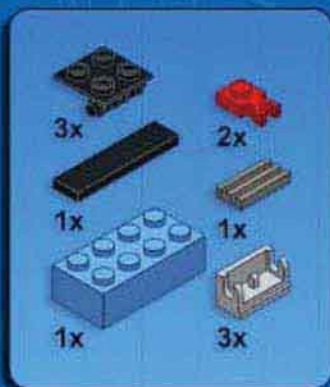



8

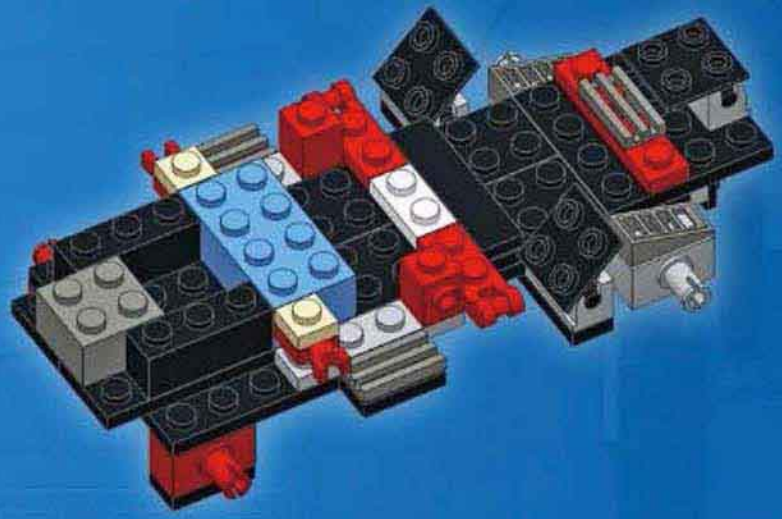
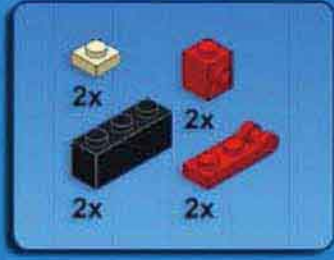

9

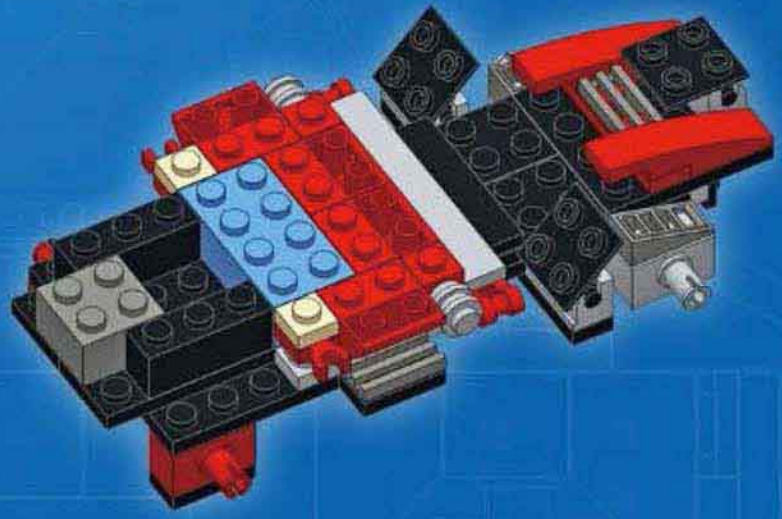
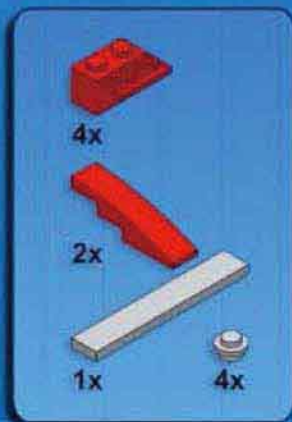

10

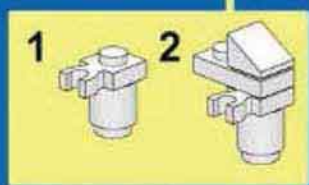
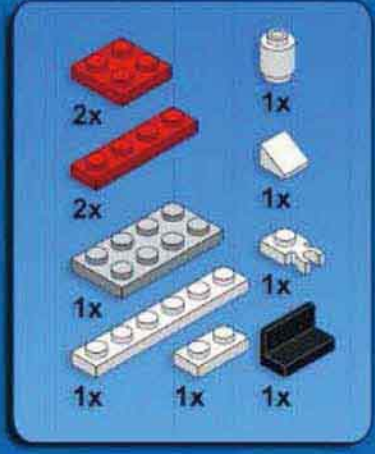

11

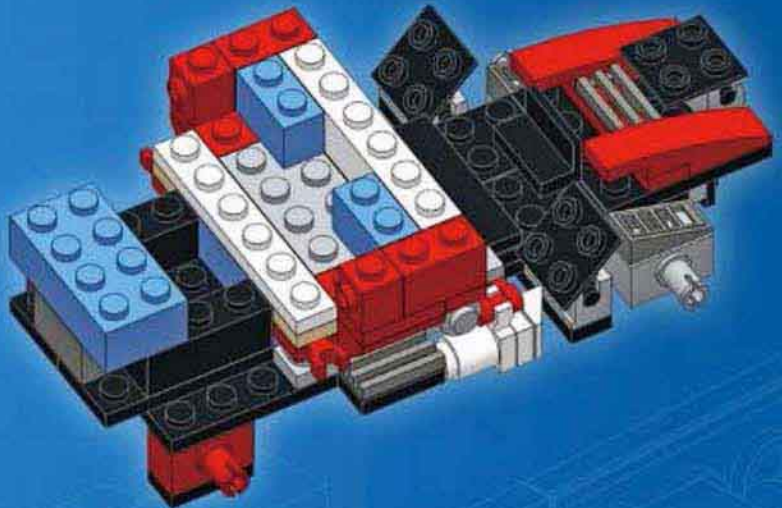
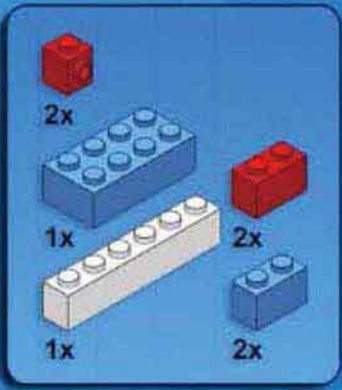

12

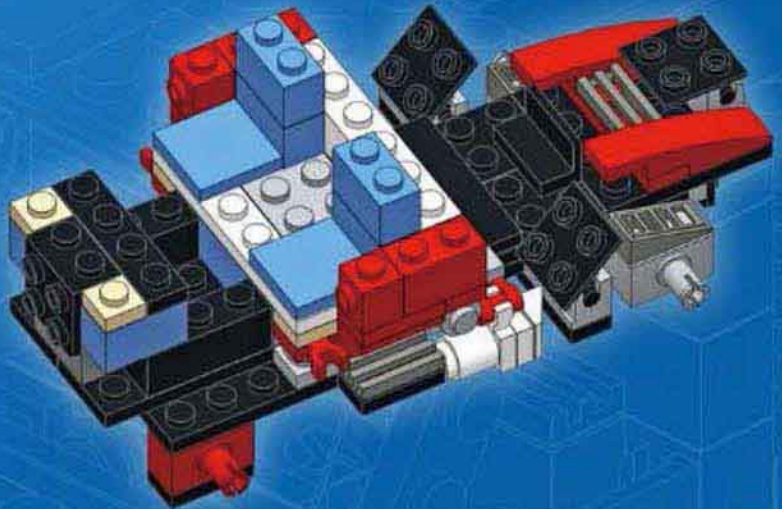
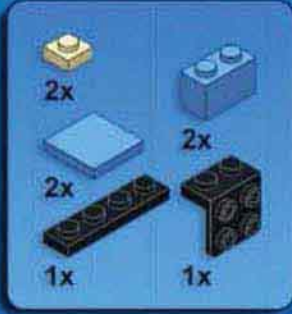

13

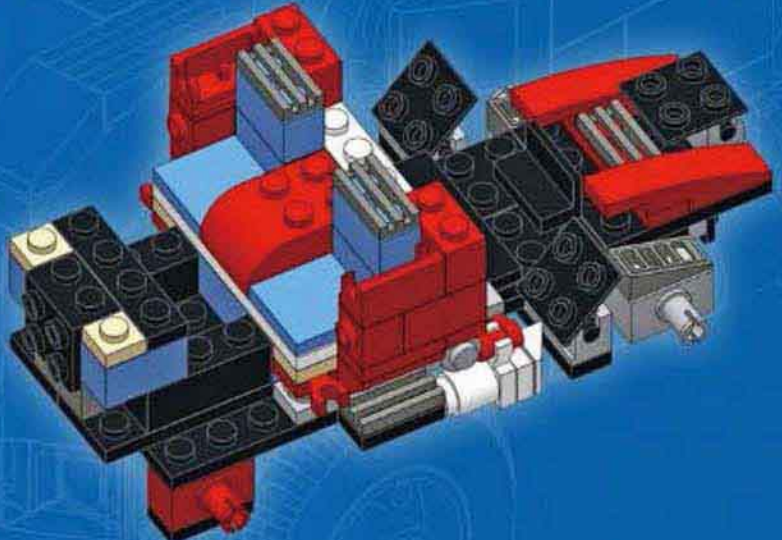
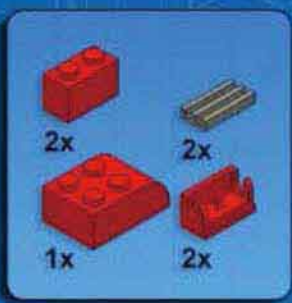



14

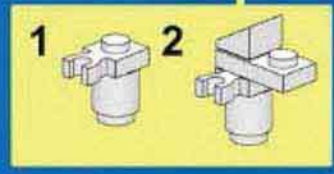
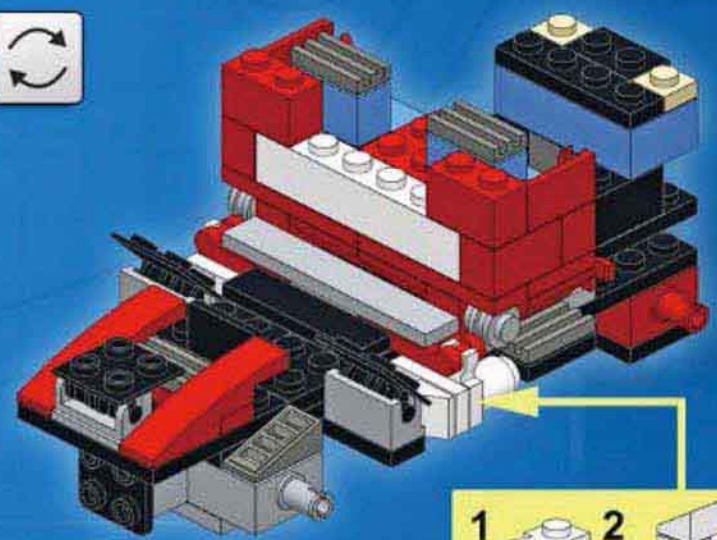

15

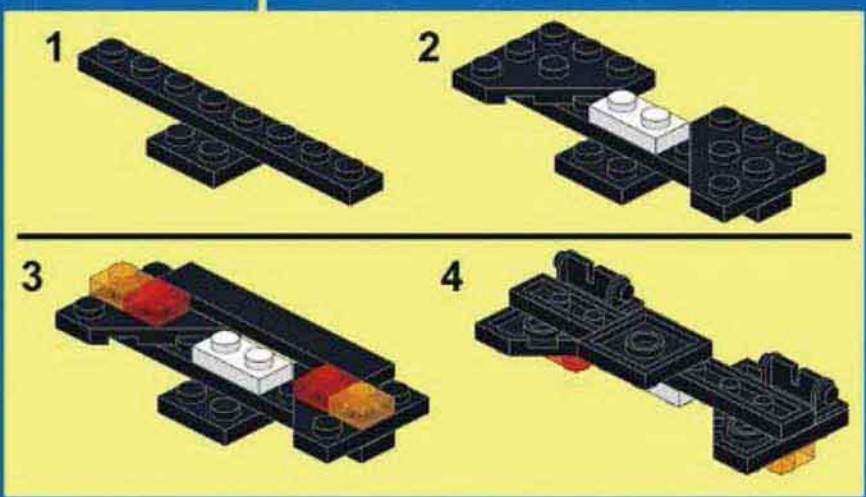
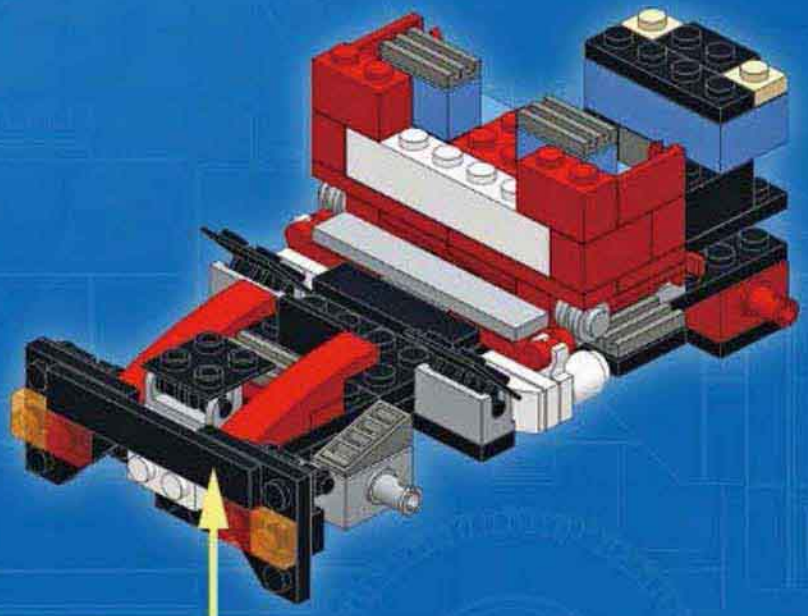
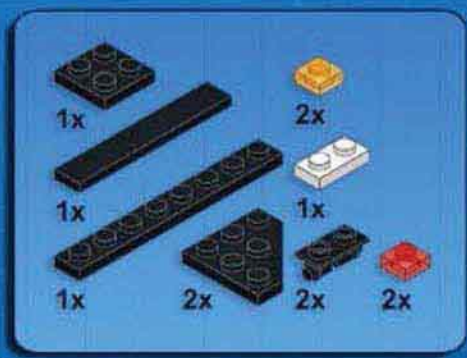

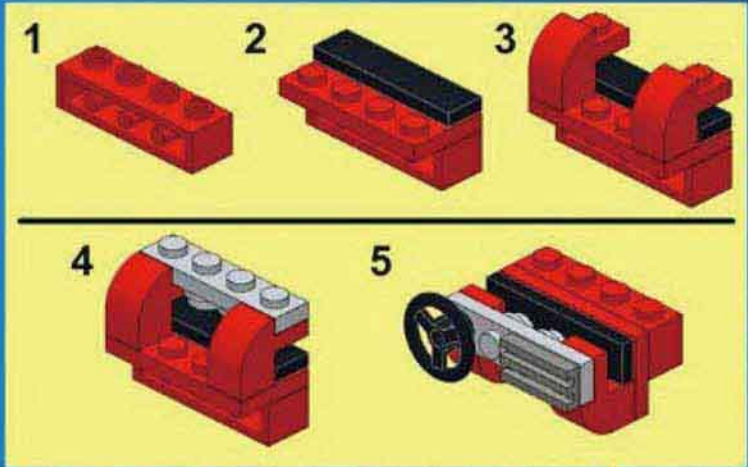

16

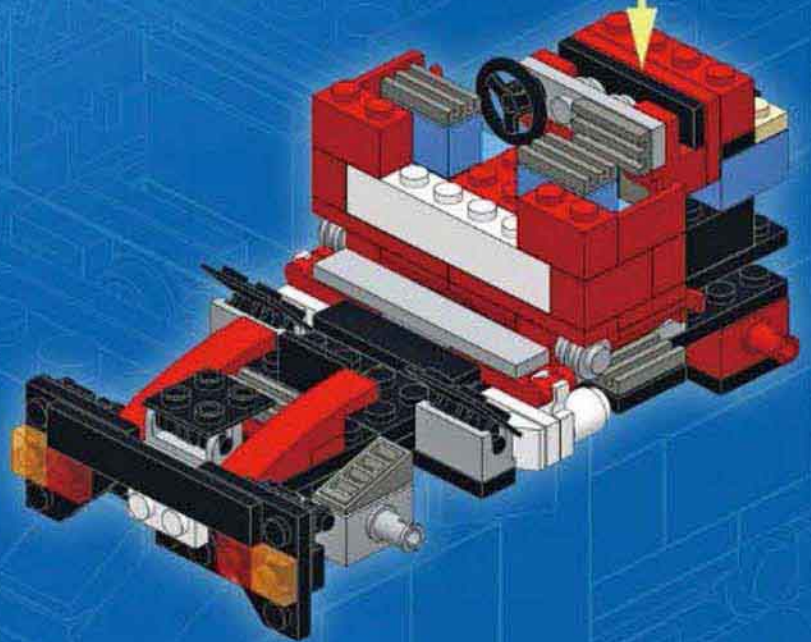
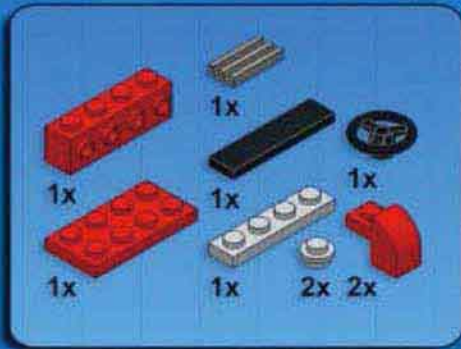



17

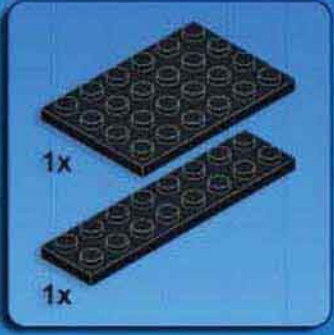

1

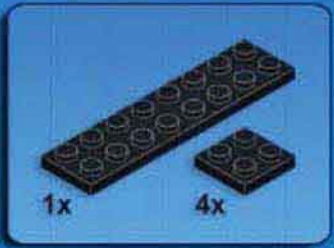

2

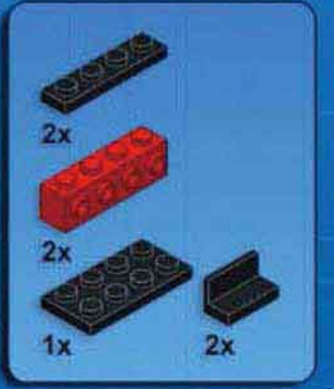

3

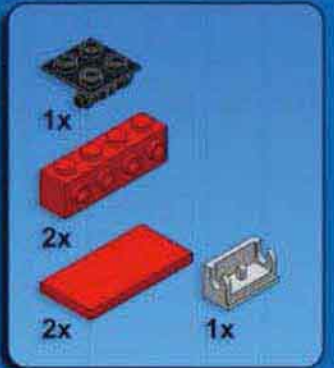
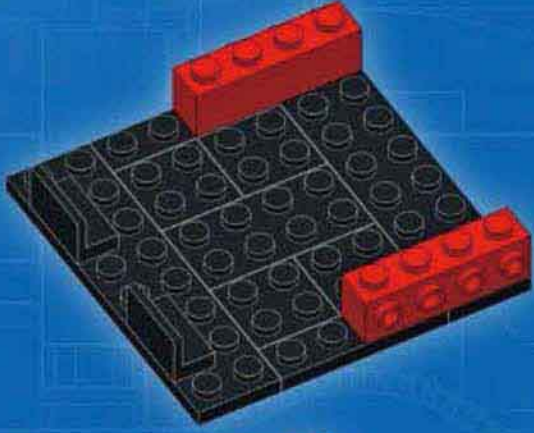

4

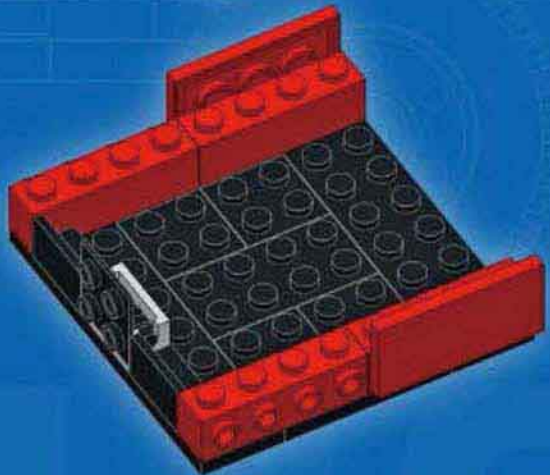

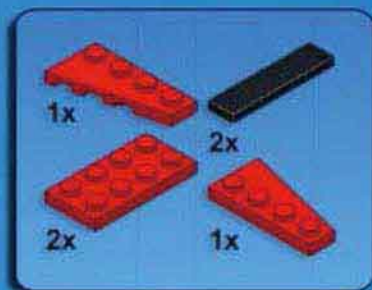

5

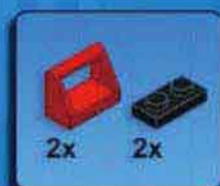
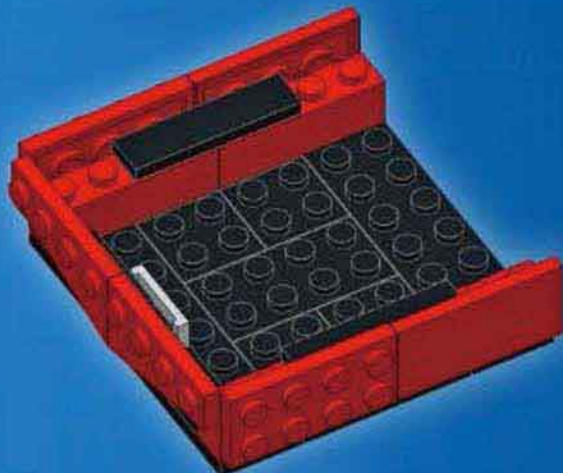

6

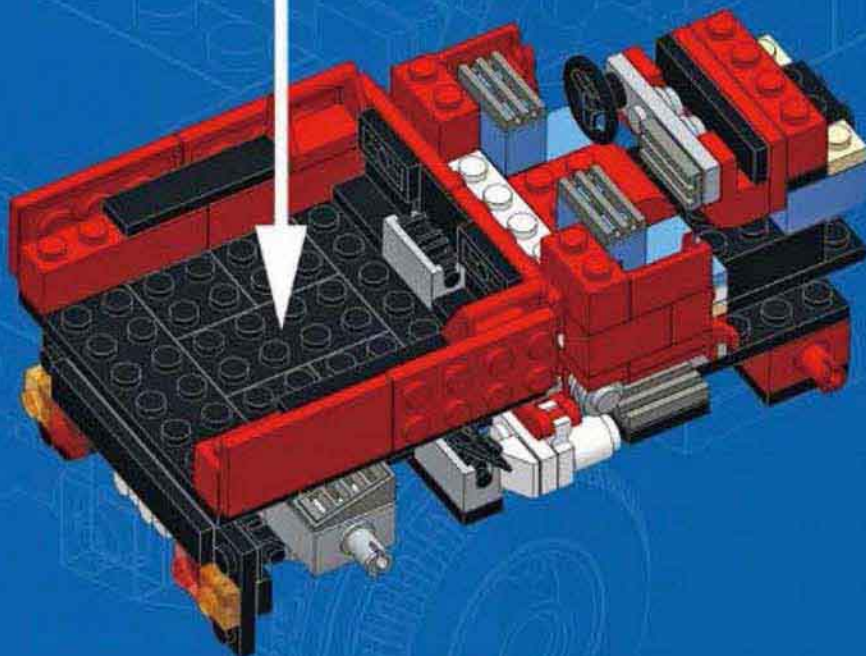
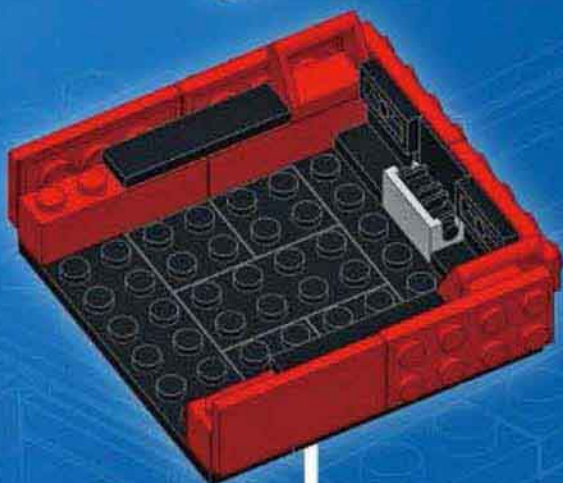



18

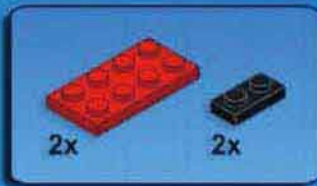

1

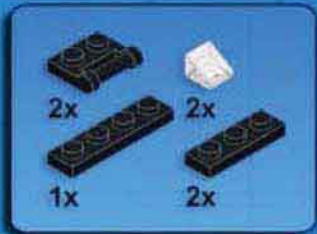
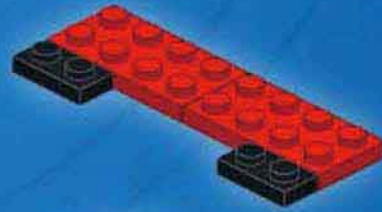

2



3

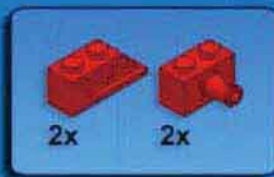

4

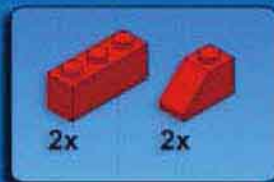
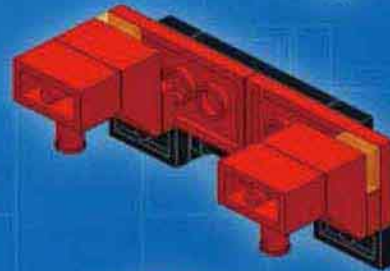

5

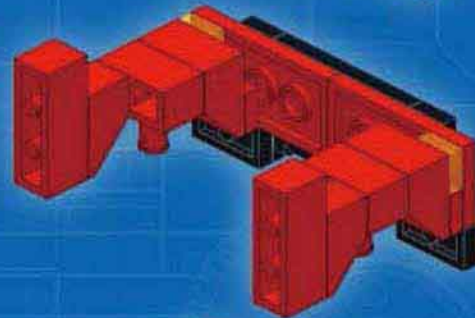

6

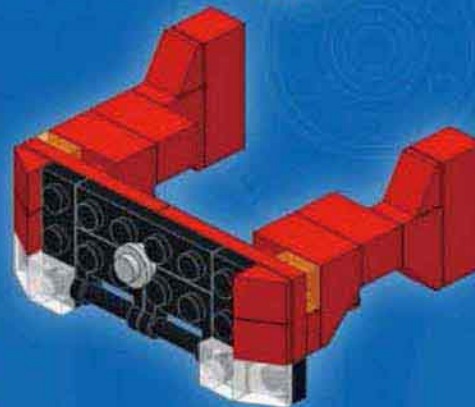



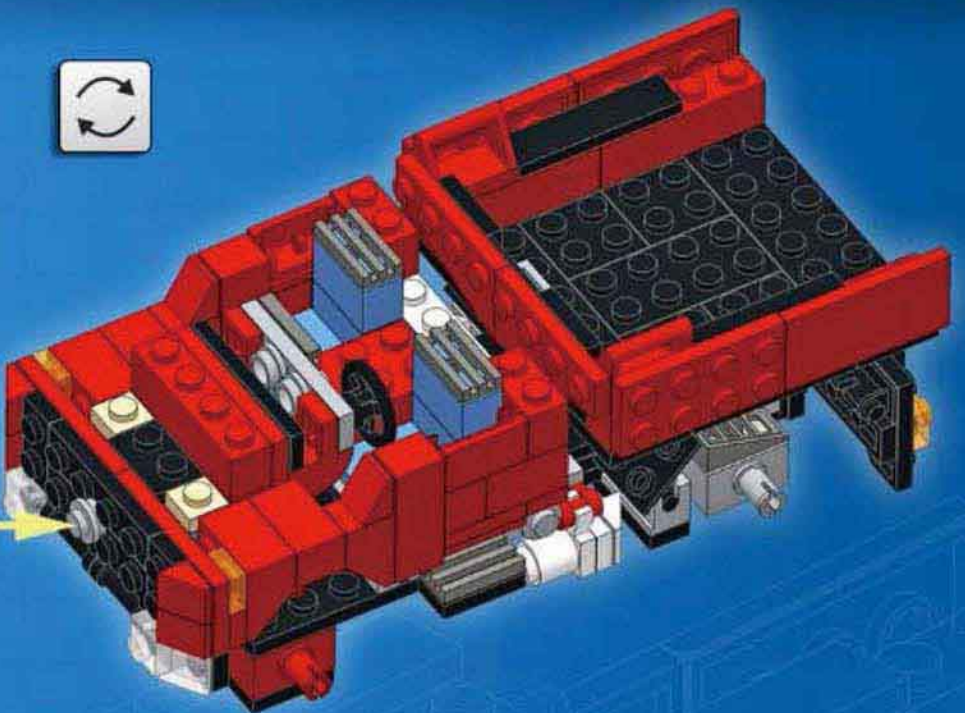
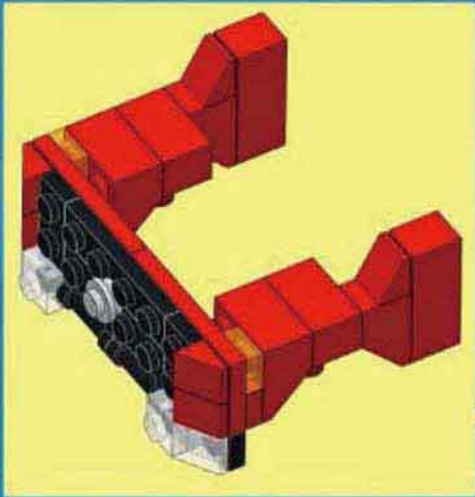

19

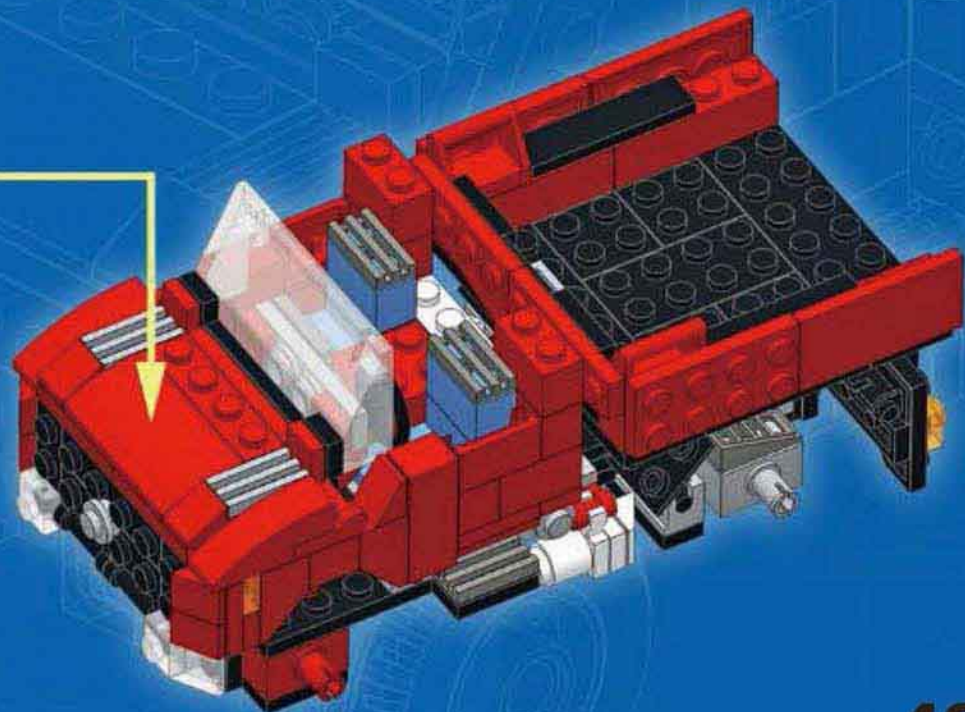
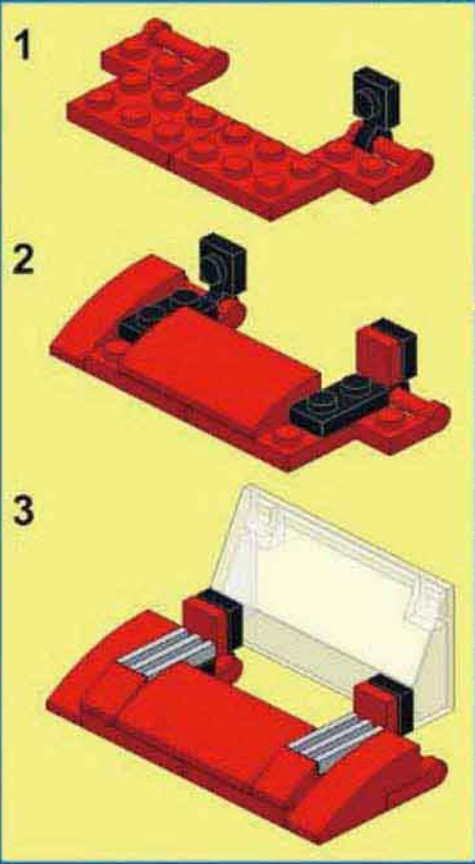
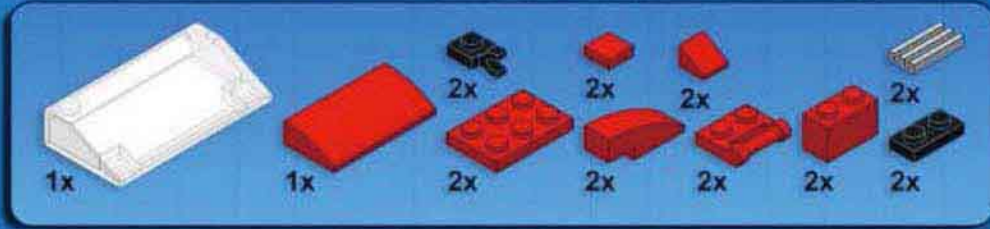



20

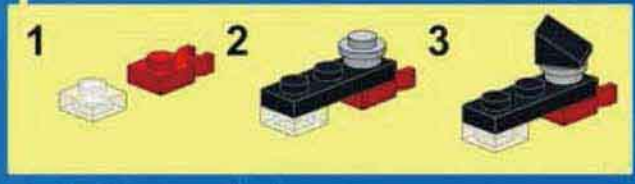
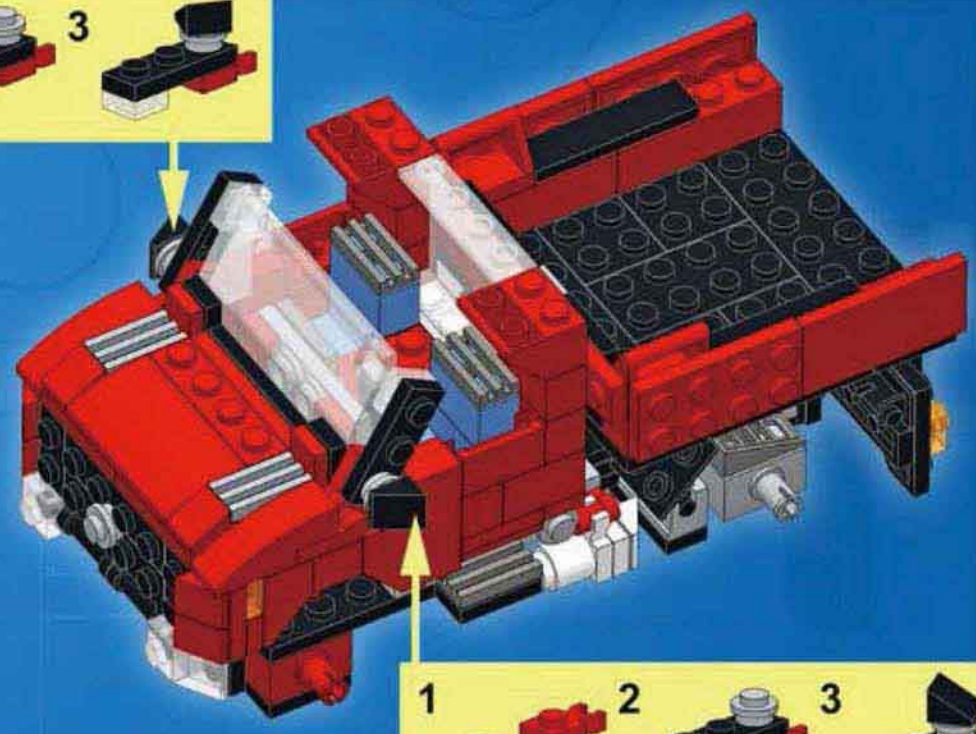
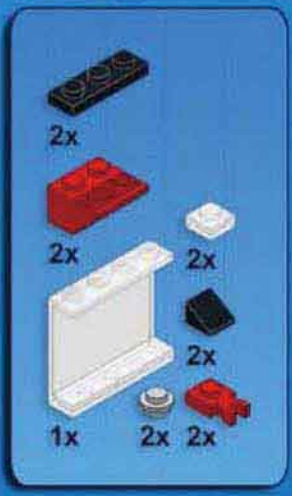

21

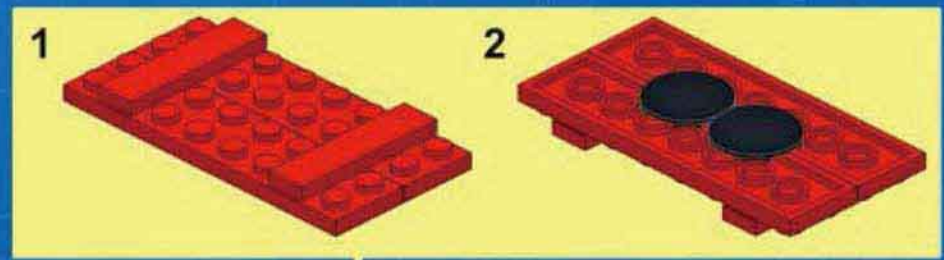
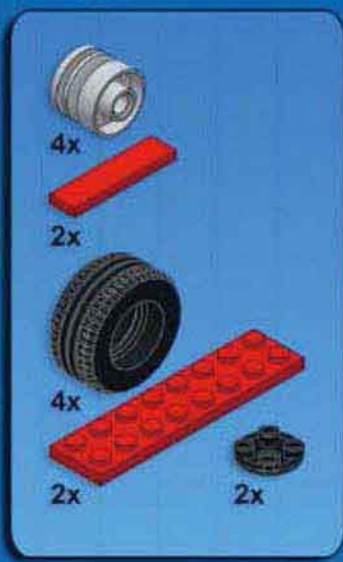



Complexity   
Functions   
Pieces 



### HISTORIC RACER

Design notes: bullet shape, minimal aeroscreen, wide wheelbase, six-cylinder engine, rollbar

#### Technical specifications:

Dimensions (l x w x h): 19 x 10 x 6 studs  
Wheelbase: 12 studs  
Axle width front/rear: 10/10 studs

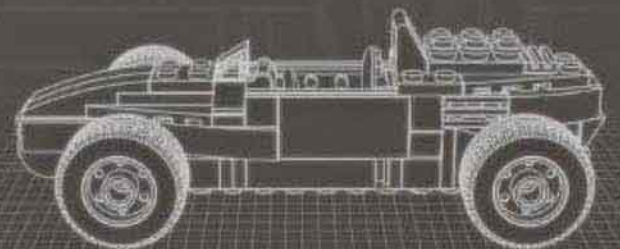

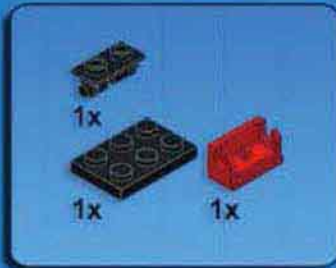

1

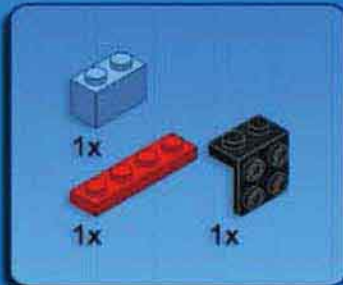

2

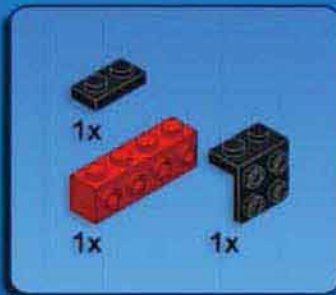

3

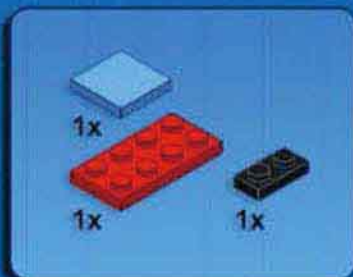

4

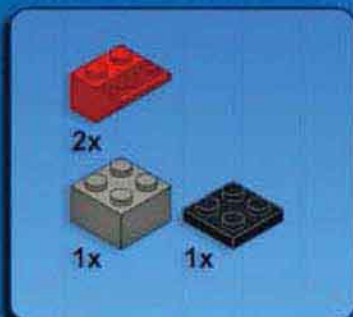

5





6

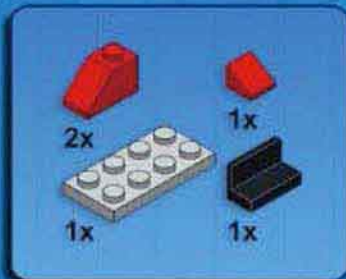
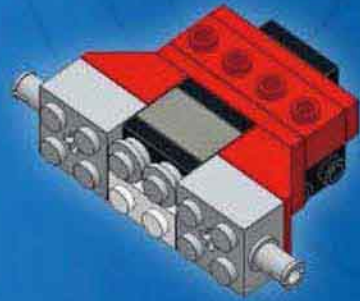

7

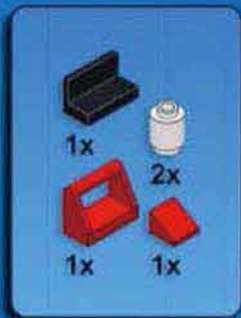
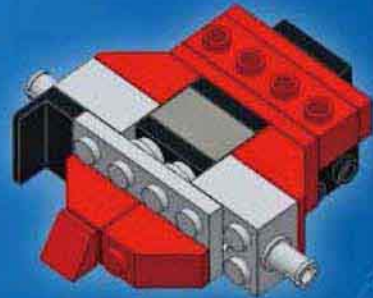

8

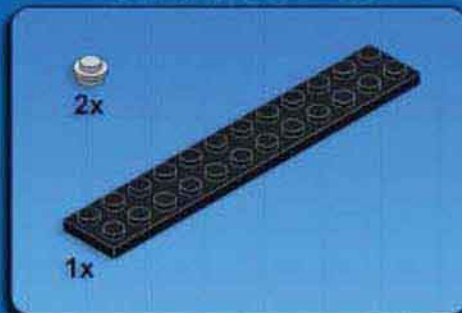

9





10

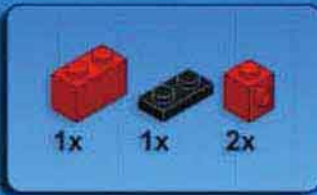

1

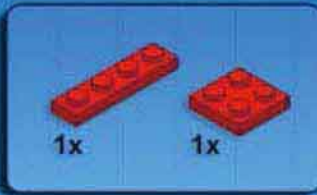

2

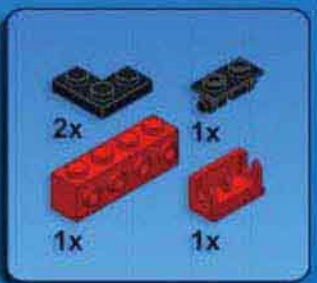

3

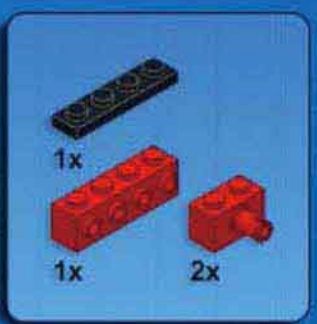
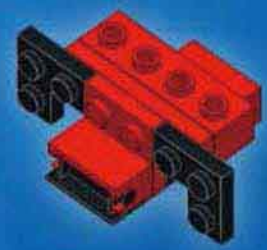

4

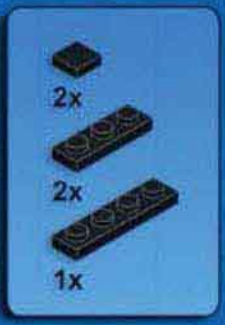
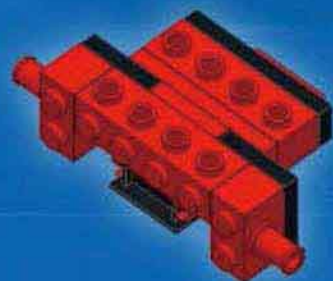

5

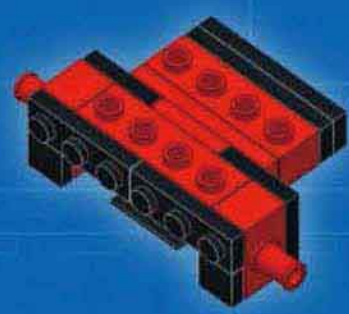

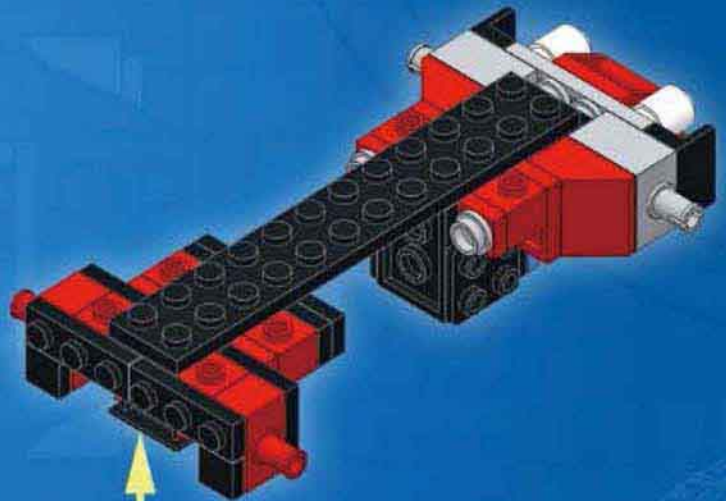
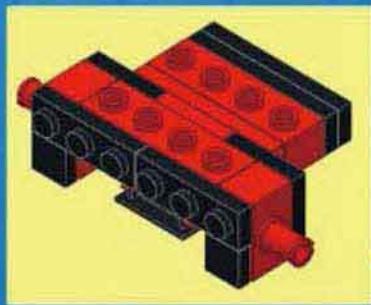

11

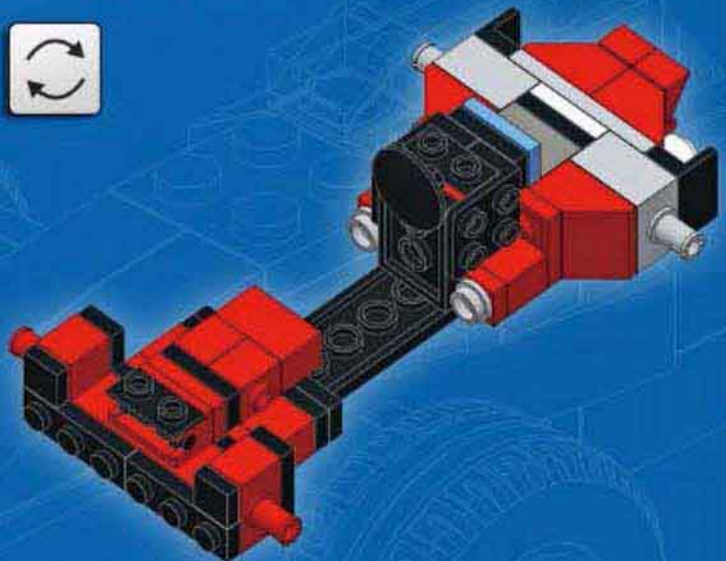



12

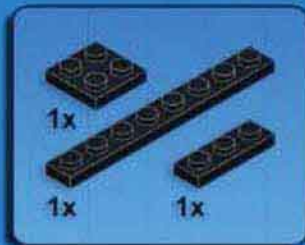

1

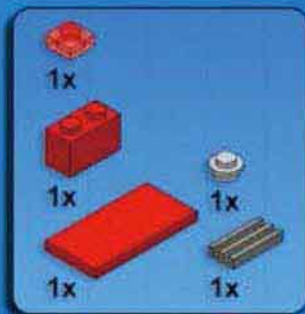

2

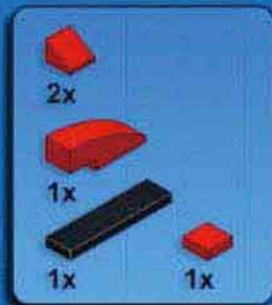
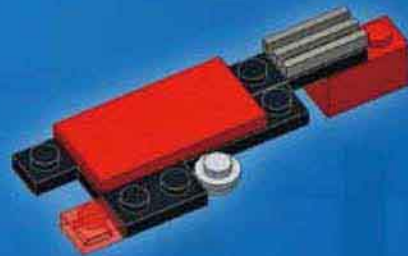

3

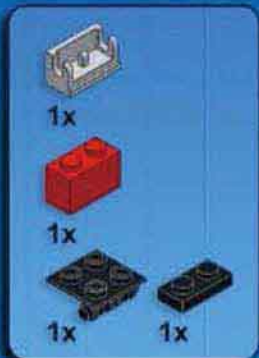
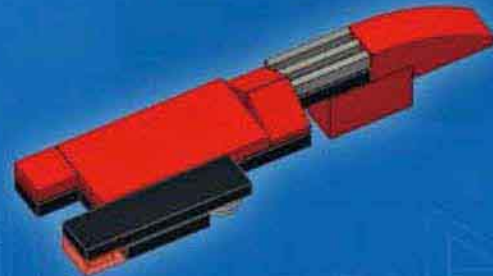

4

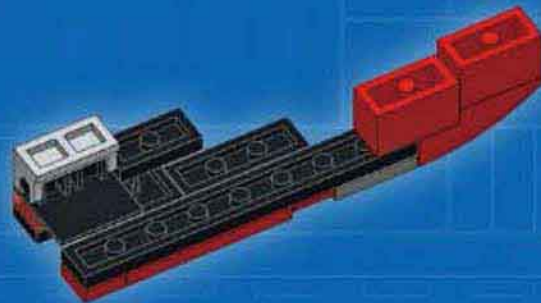



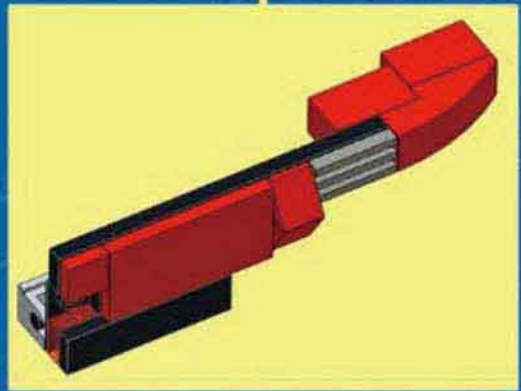
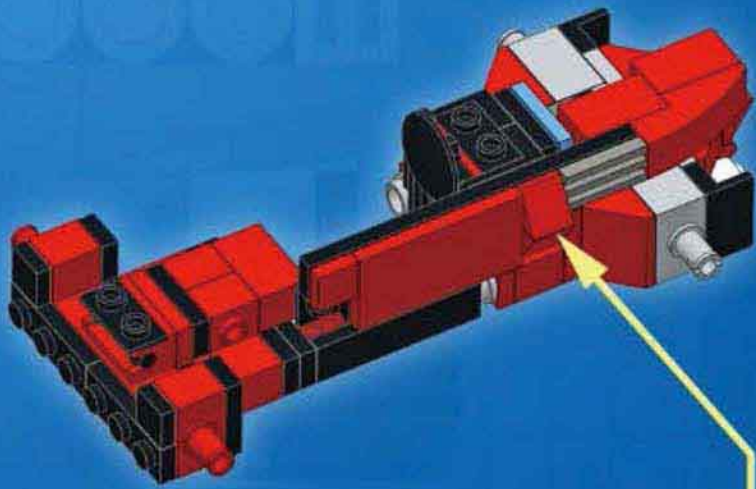
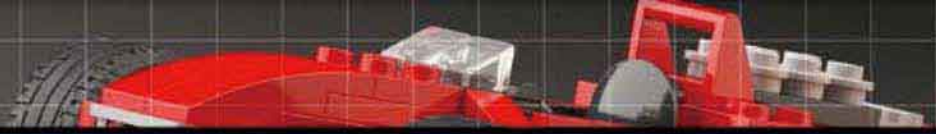



14

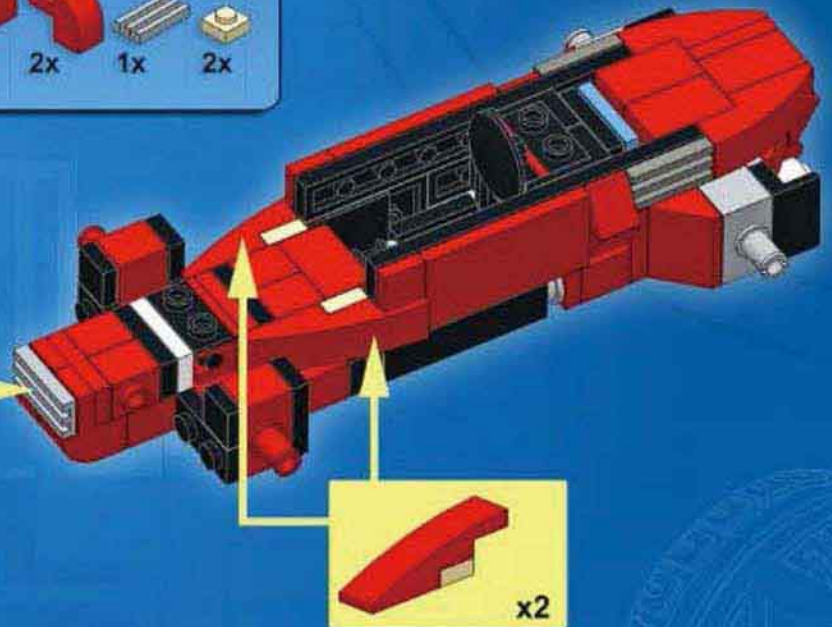
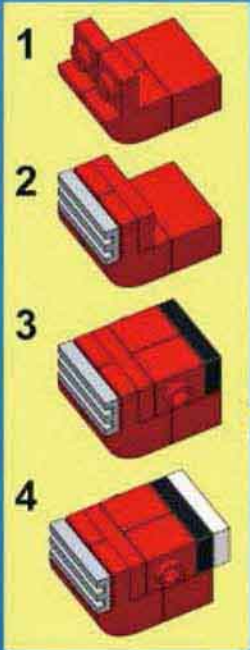
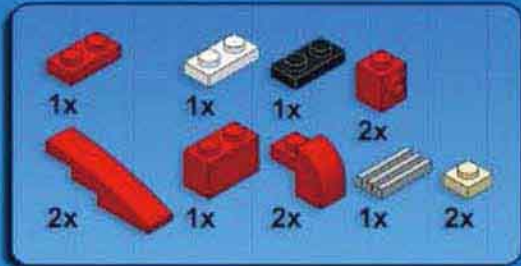

15

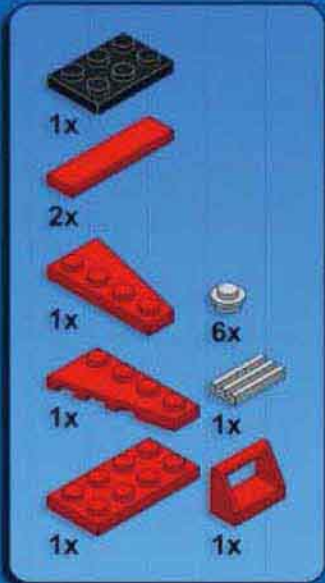

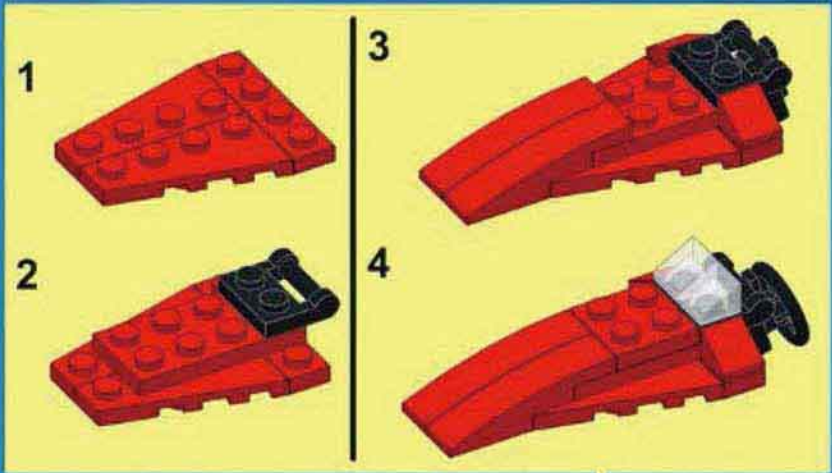

16

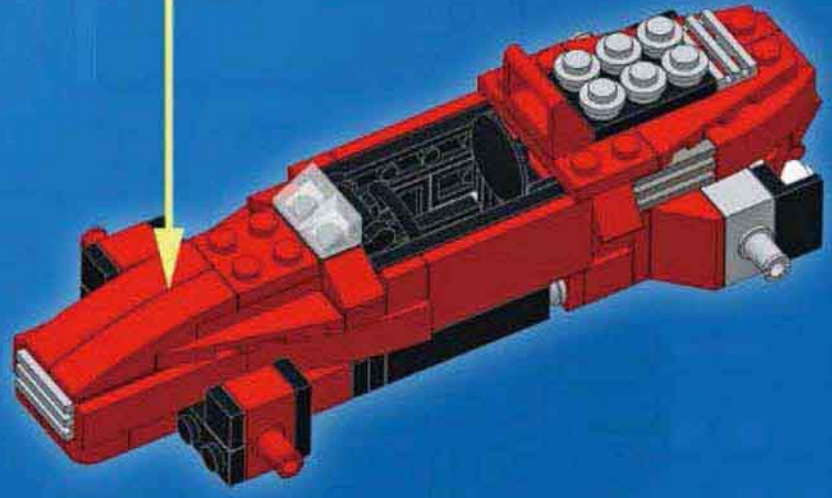
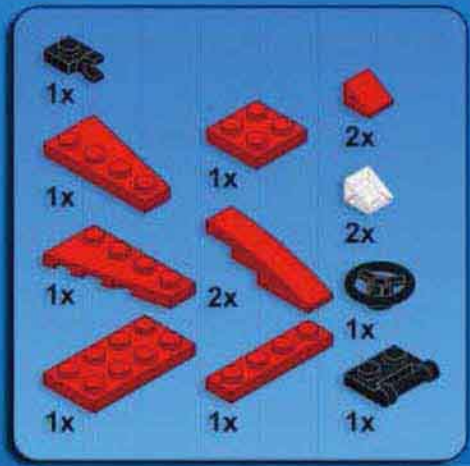

17





Complexity   
Functions   
Pieces 

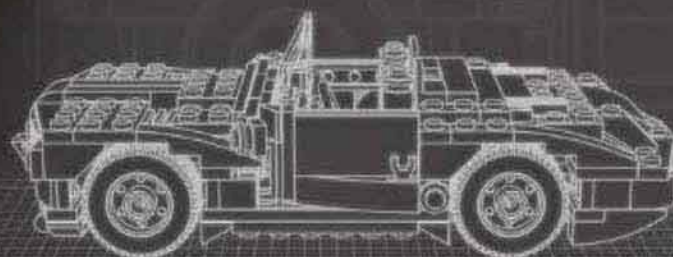
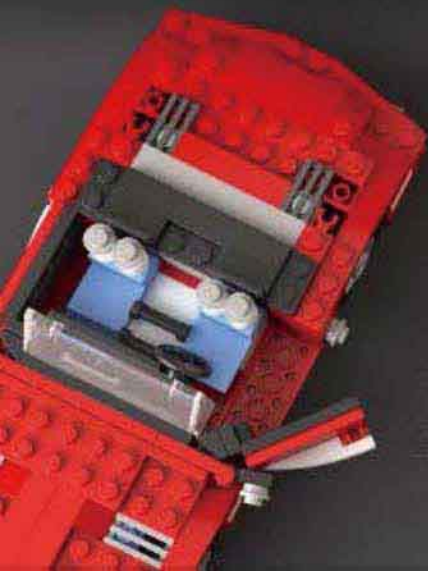
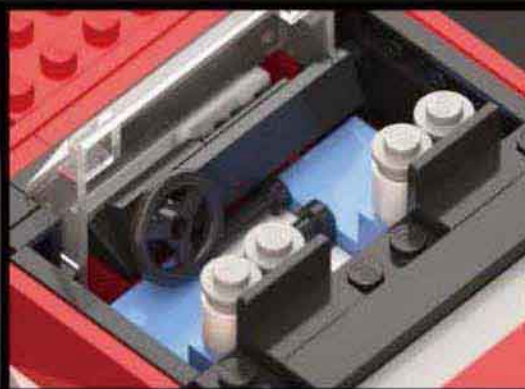
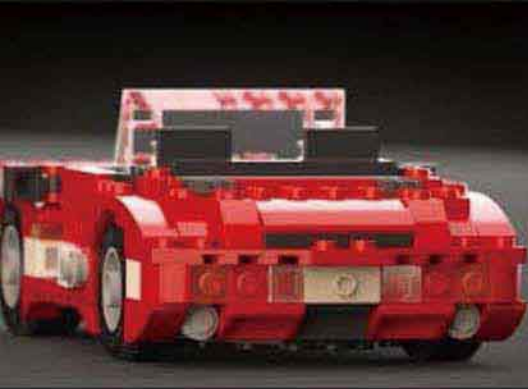

## CLASSIC CAR

Design notes: wide chassis, convertible, wide stripe, classic curves

### Technical specifications:

Dimensions (l x w x h): 23 x 13 x 7 studs

Wheelbase: 12 studs

Axle width front/rear: 10/10 studs

Features: opening doors

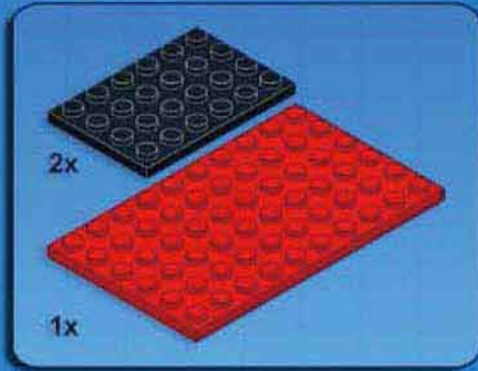

1

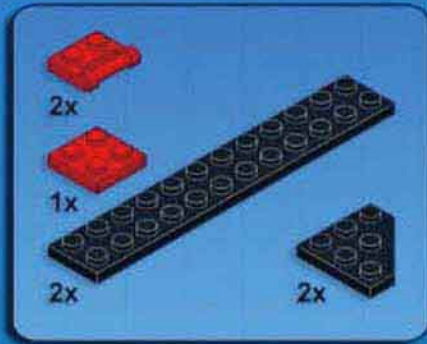
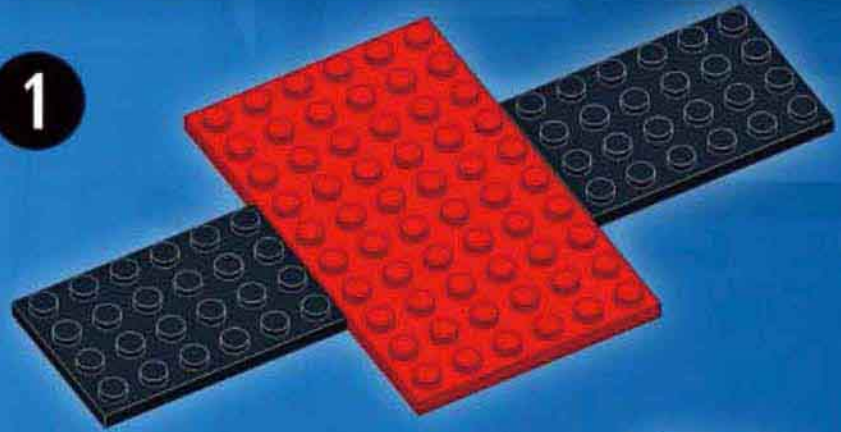

2

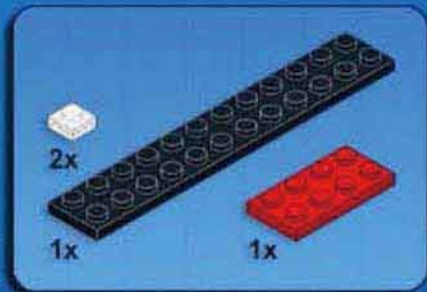
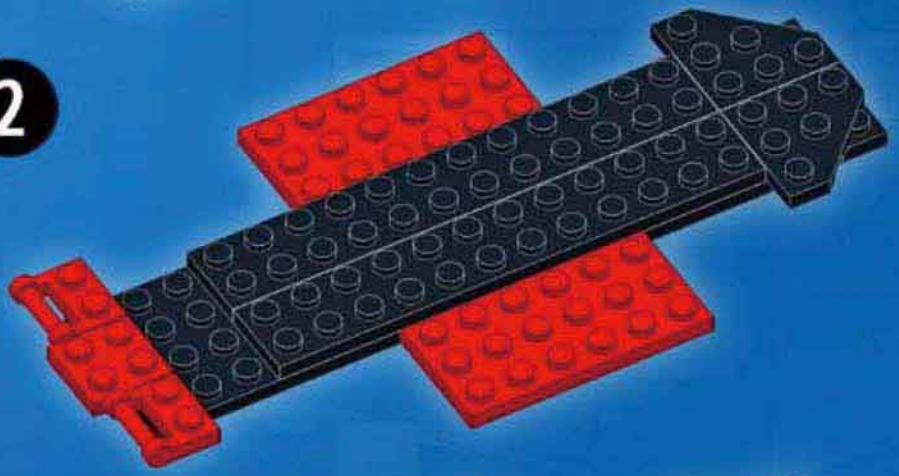

3

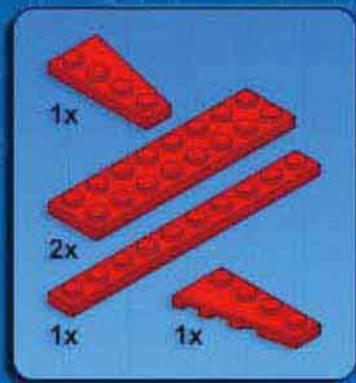
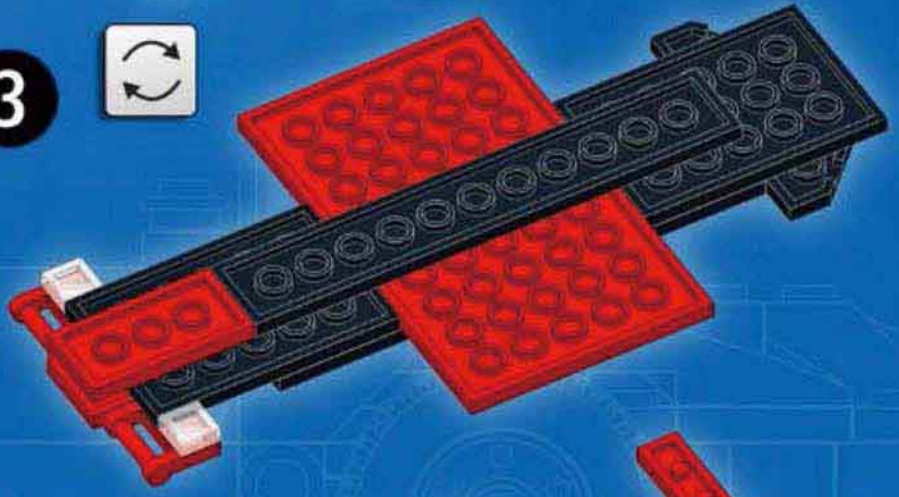

4

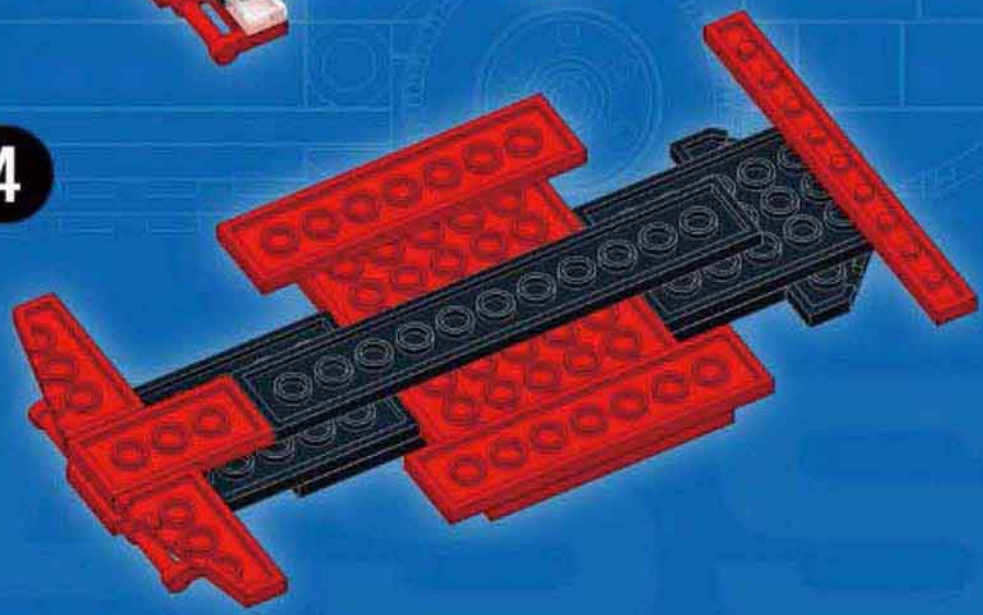

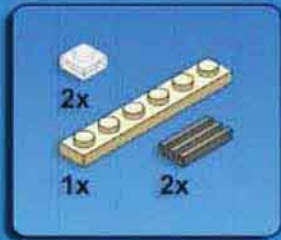

5

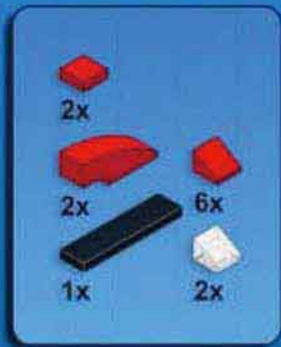
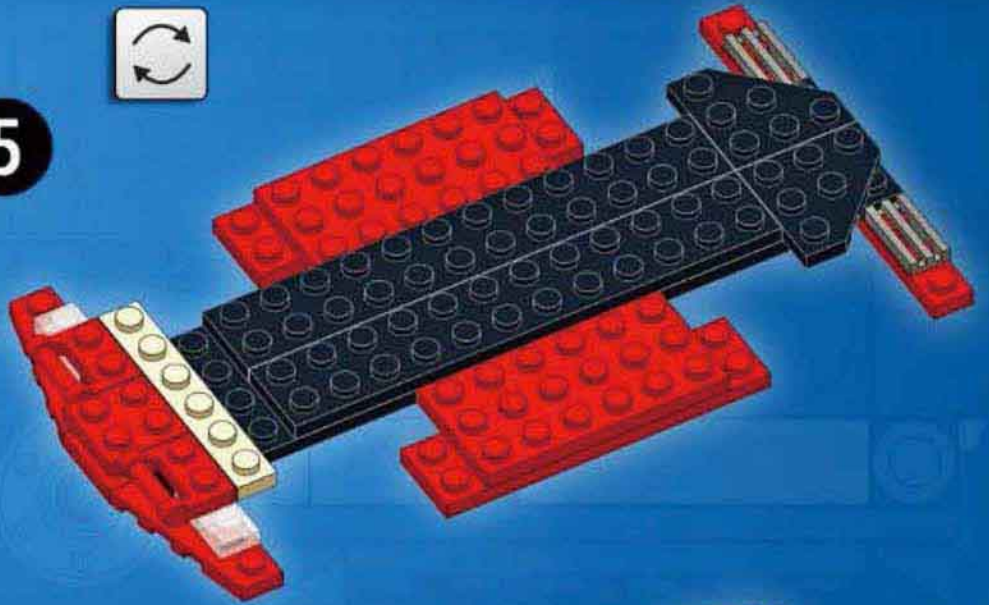

6

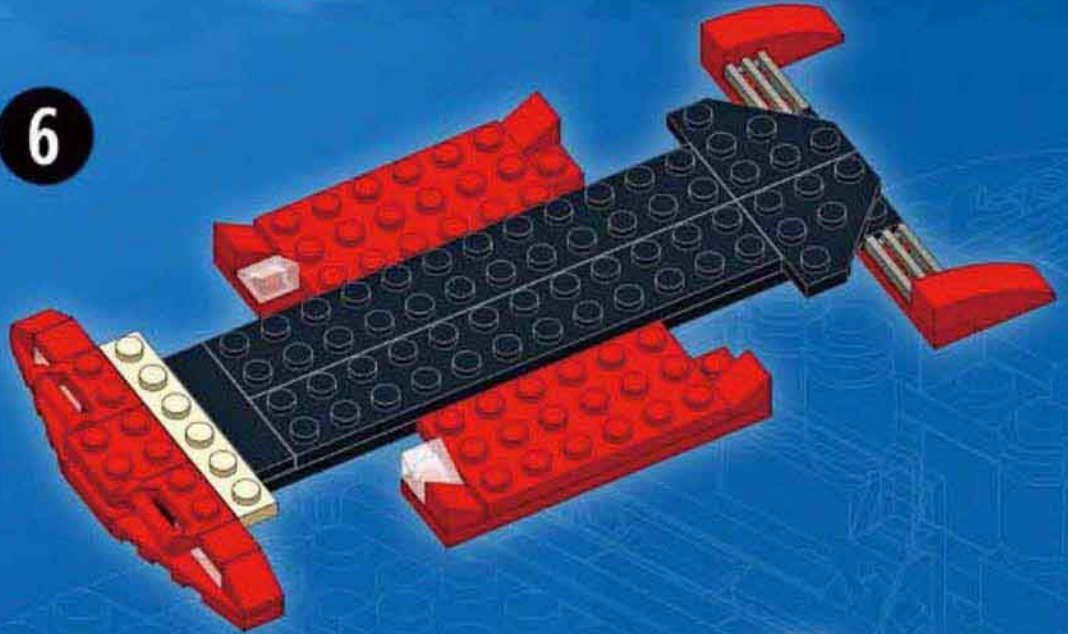

7

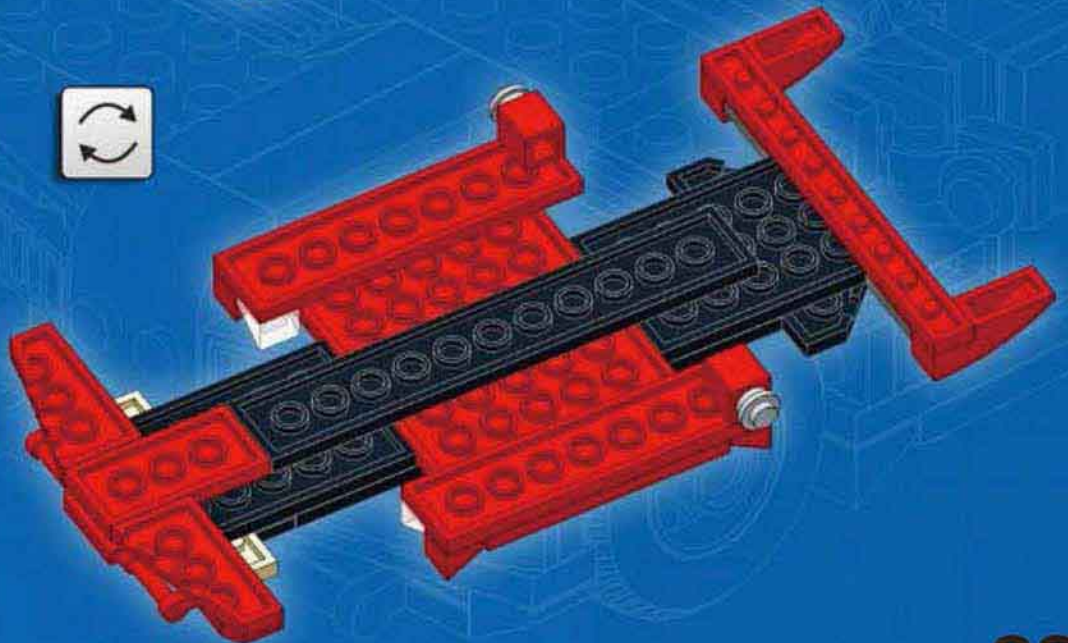



8

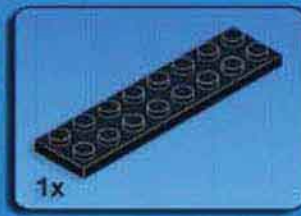

1x



2x

2x

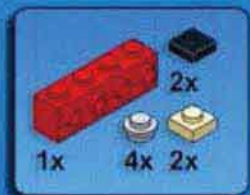

1x

4x

2x

2x



2x

2x

2x



1x

2x

2x

1x

1

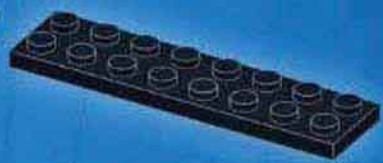

2

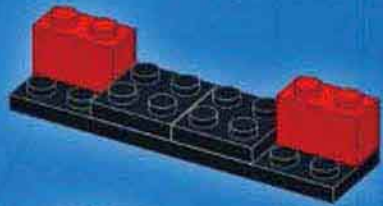

3

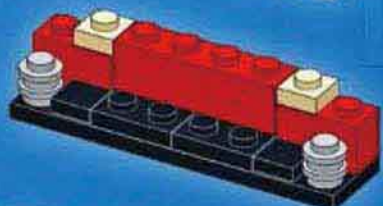

4



5



6



2x

2x

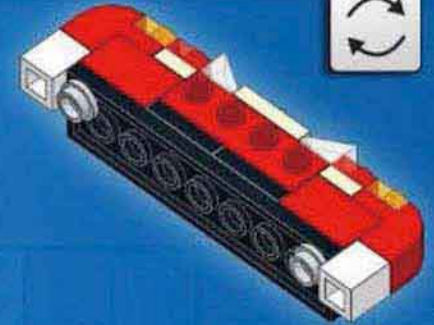

7

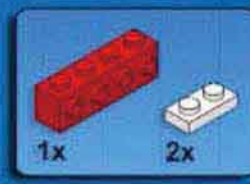

1x

2x

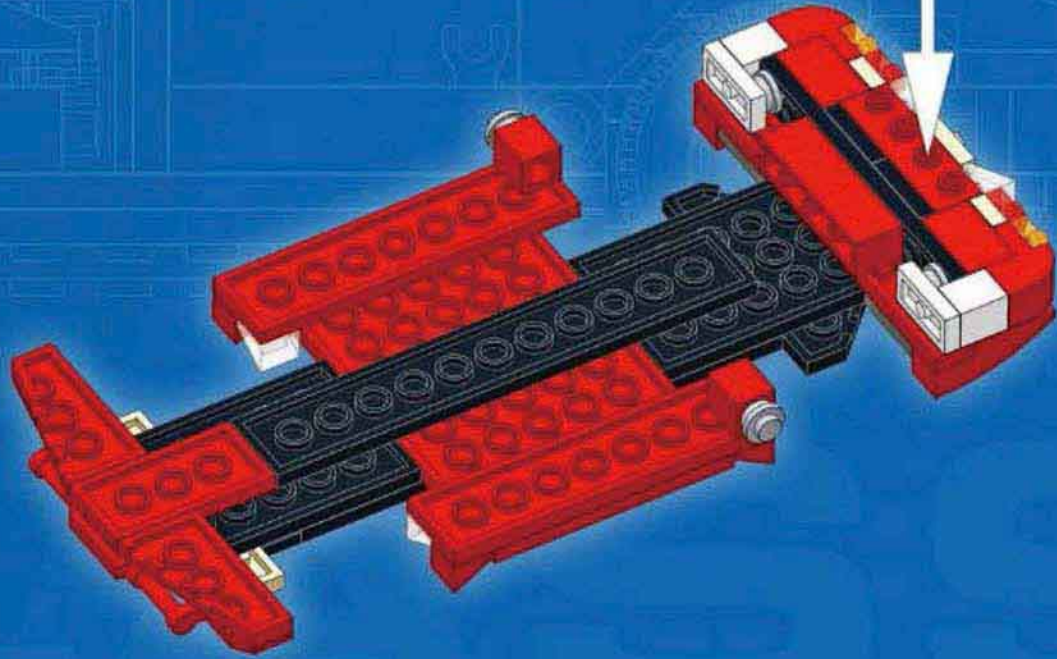
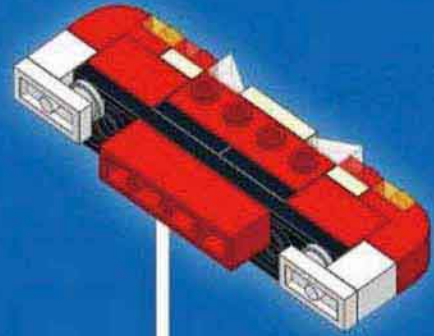



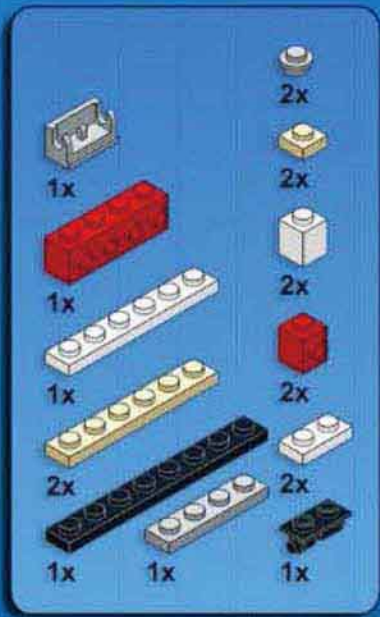
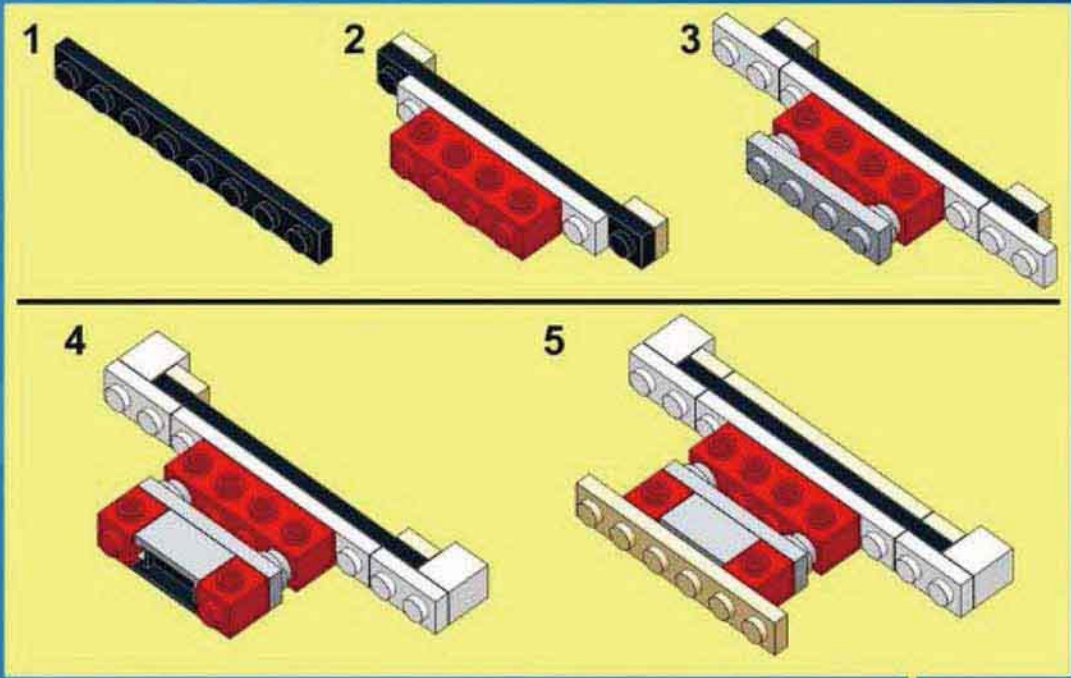

9

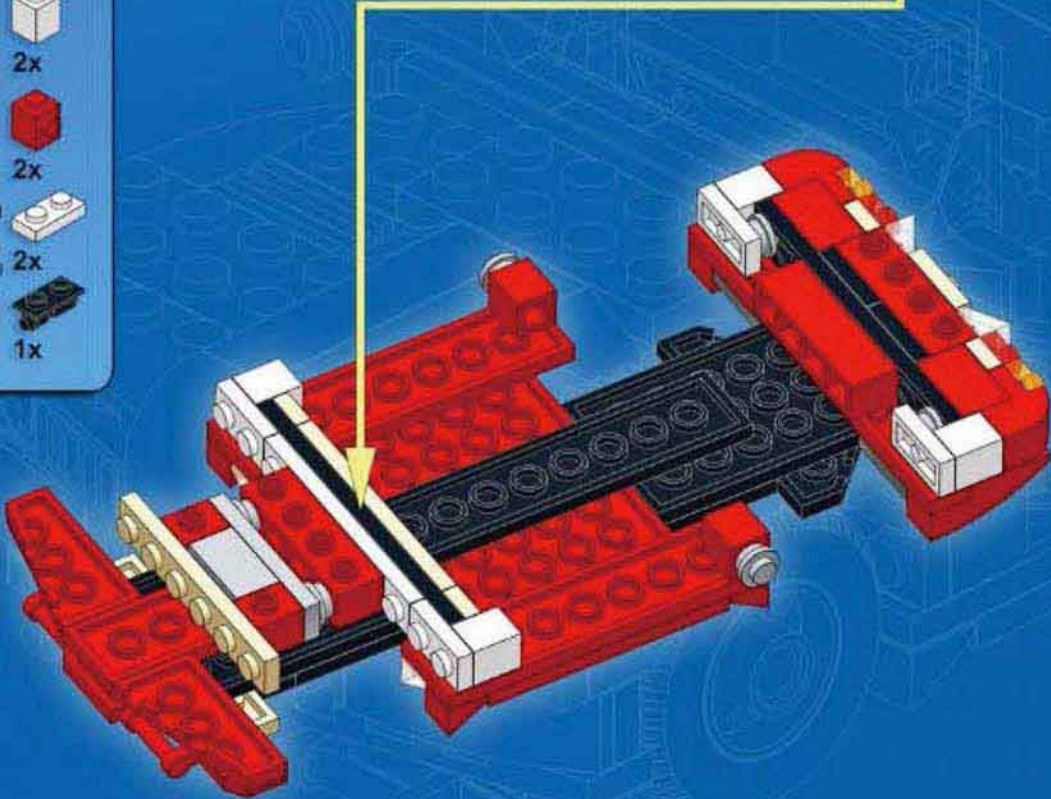





12

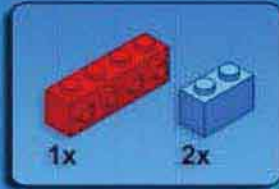

1

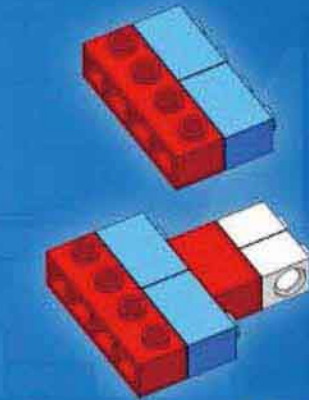

2

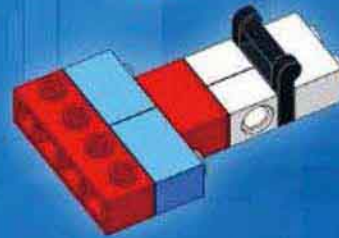

3

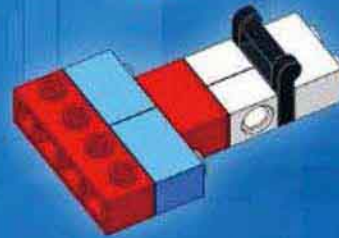

4

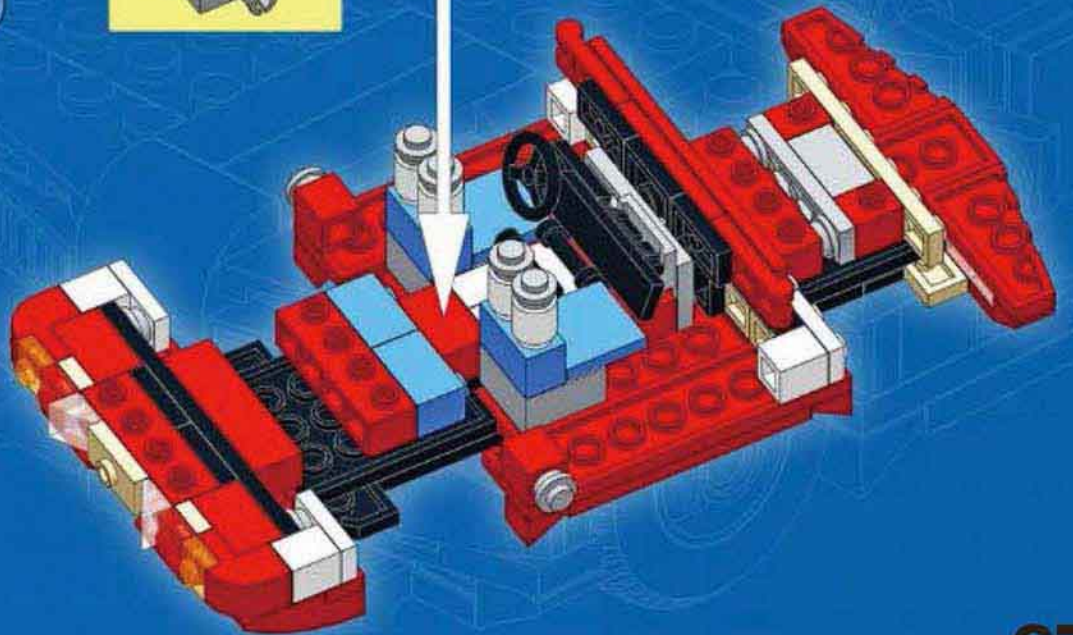
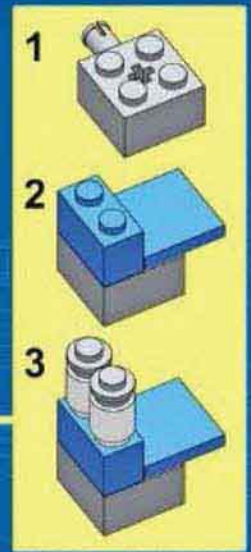
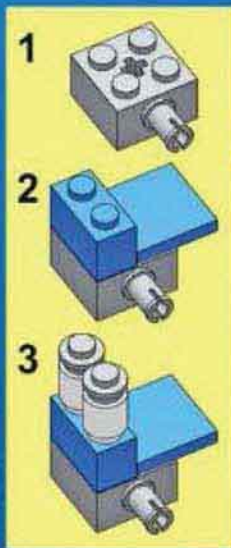



13

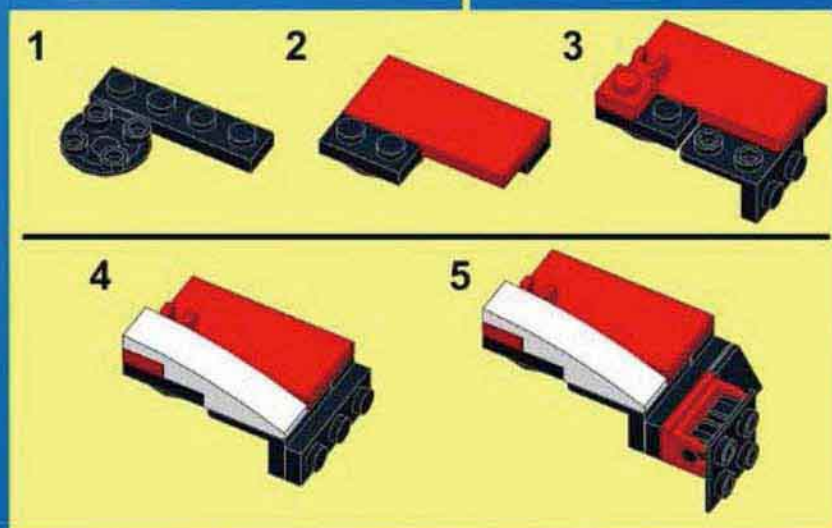
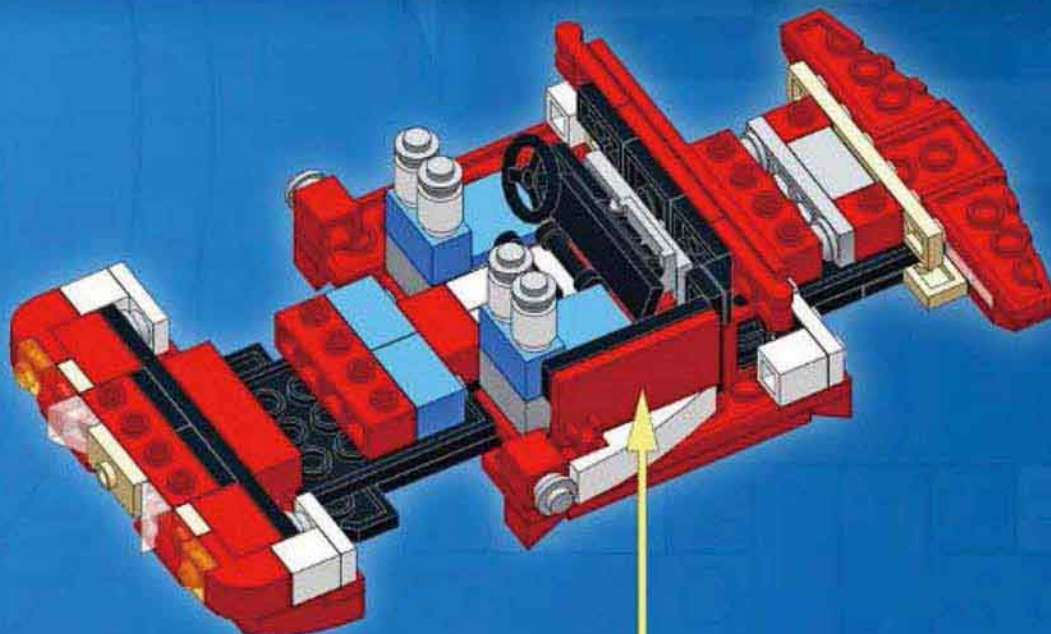
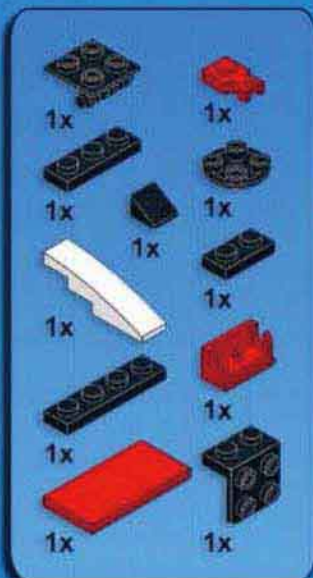

14

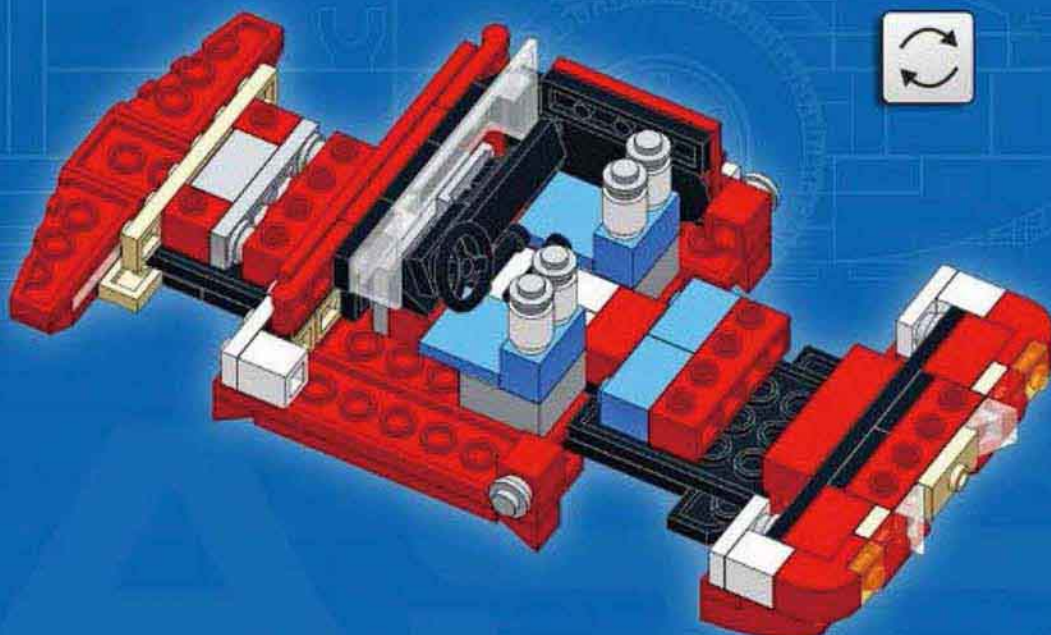



15

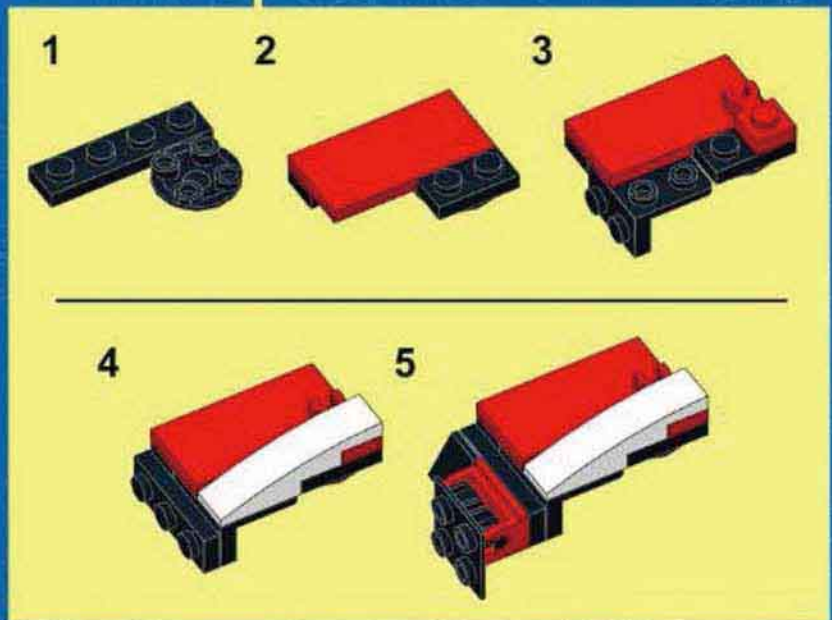
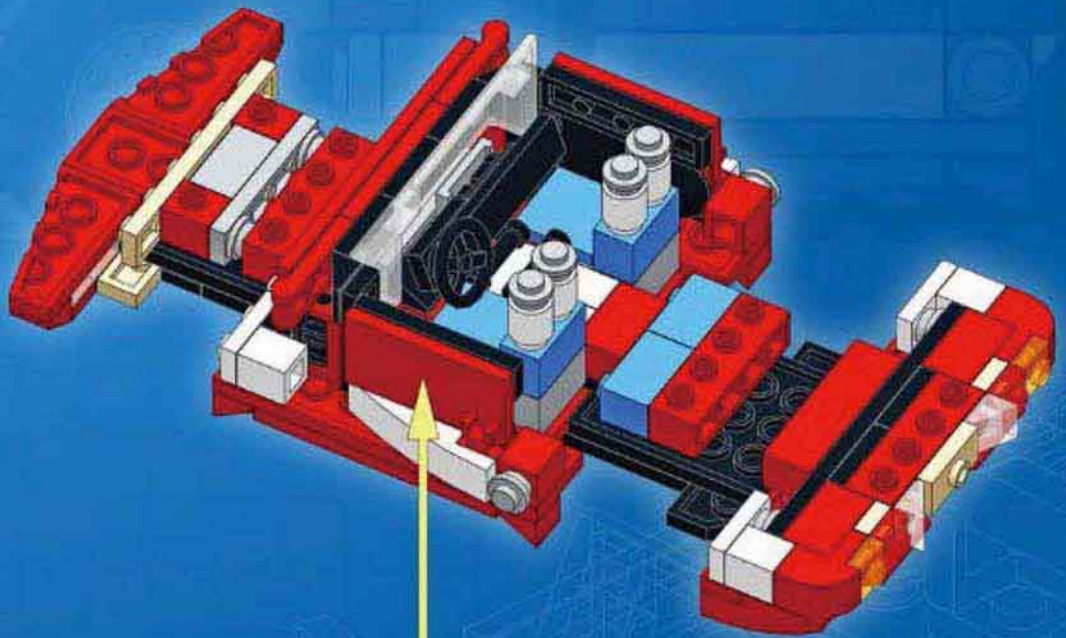
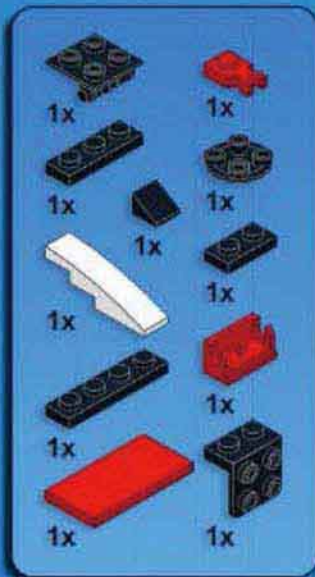



16

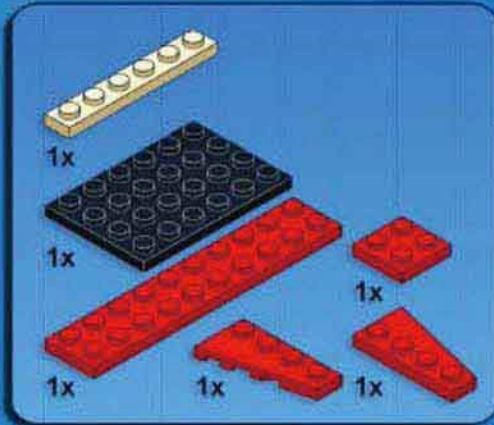

1

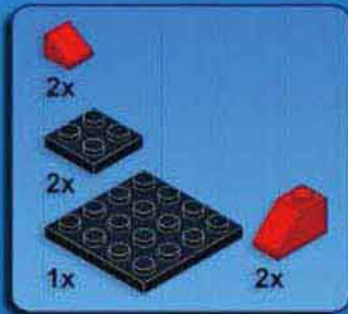
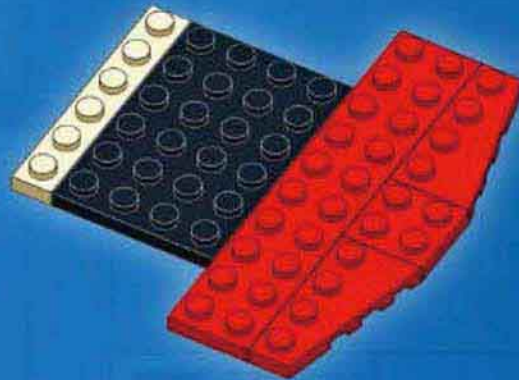

2

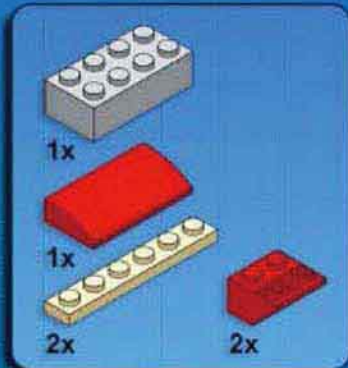
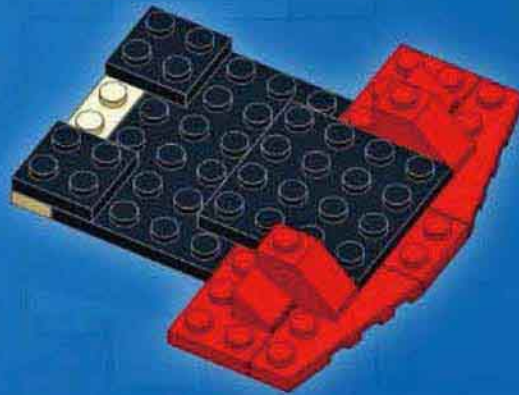

3

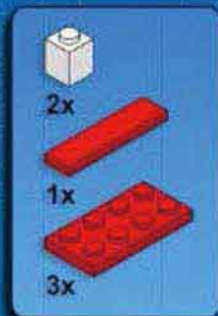
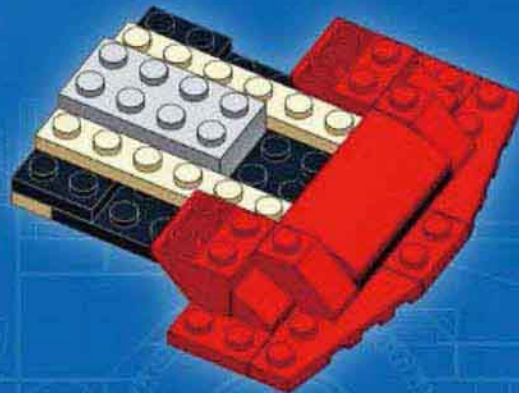

4

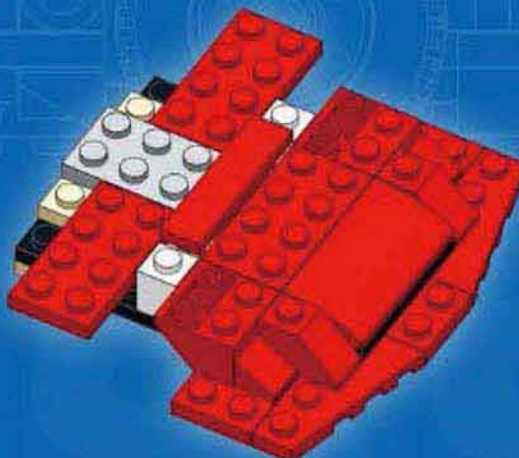

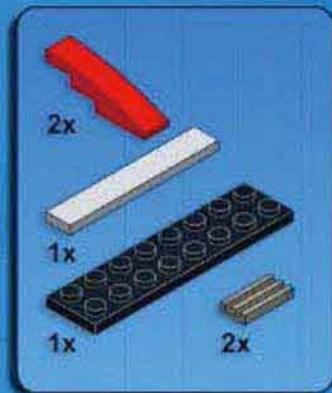

5

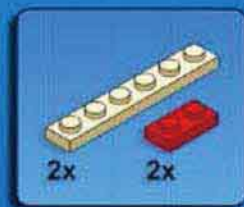
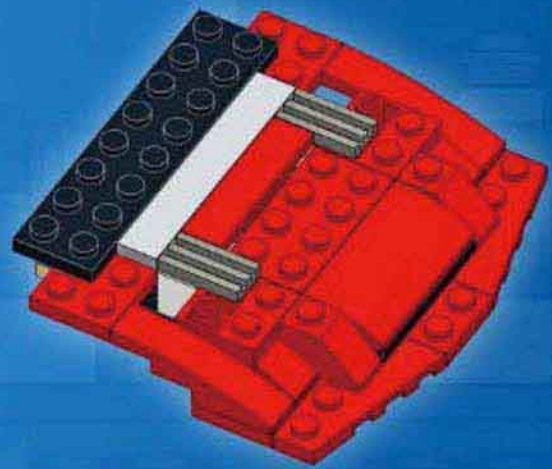

6

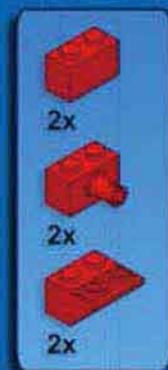
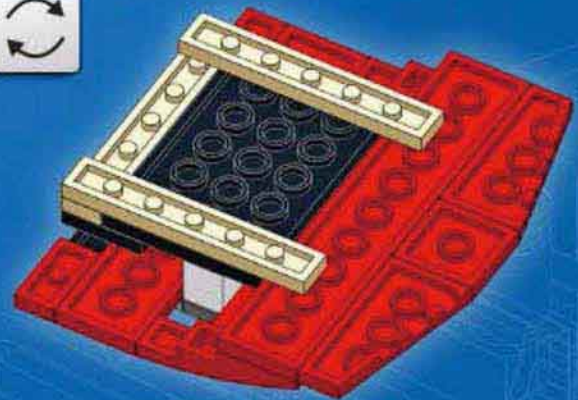

7

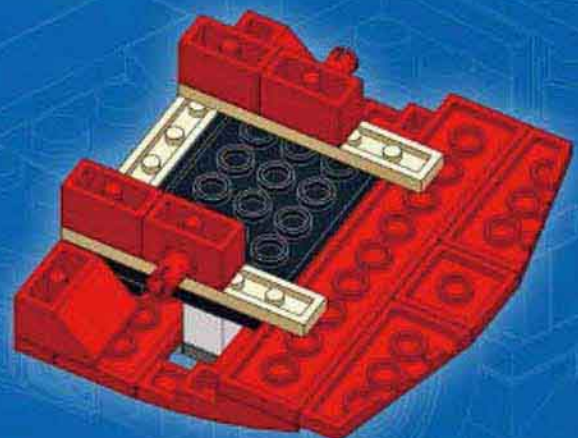



8

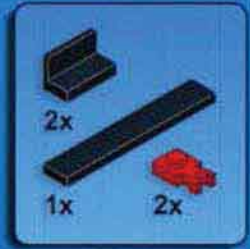
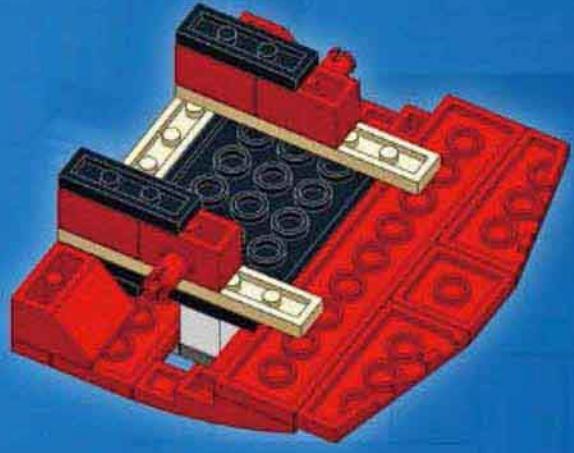

9

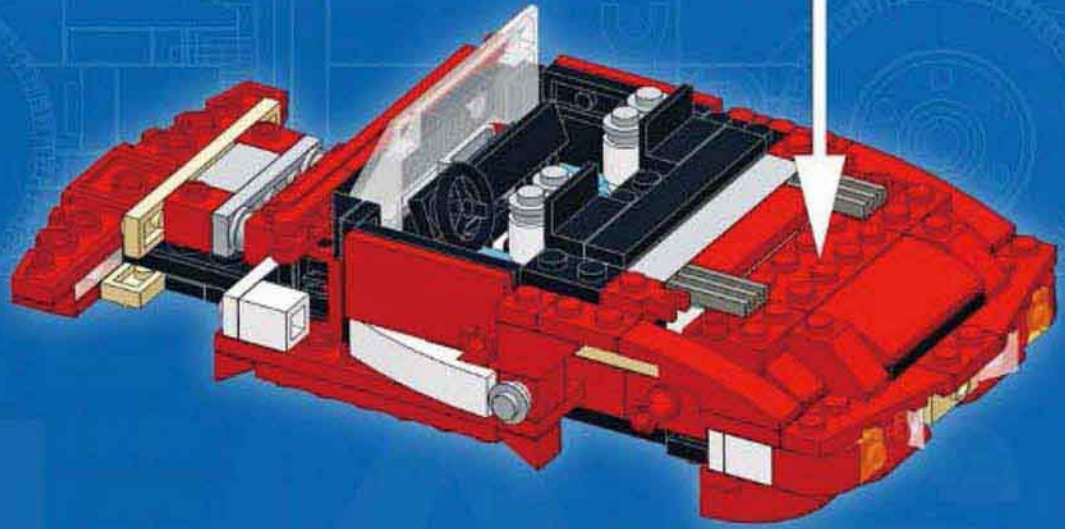
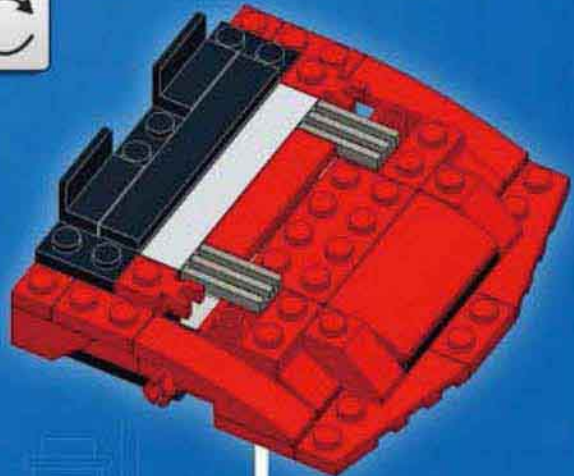





17

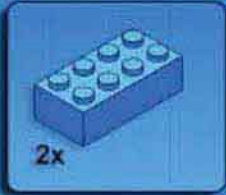

1

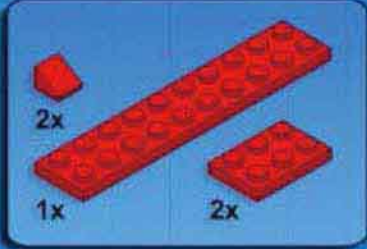
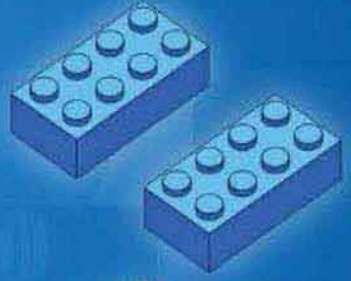

2

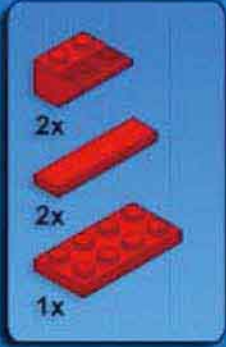
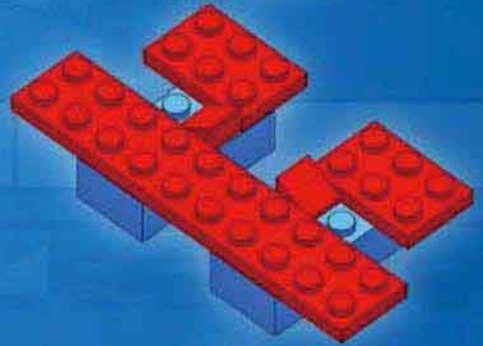

3

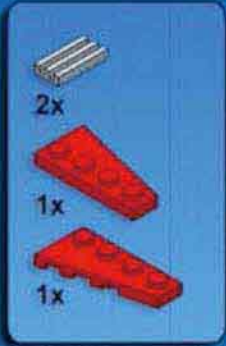
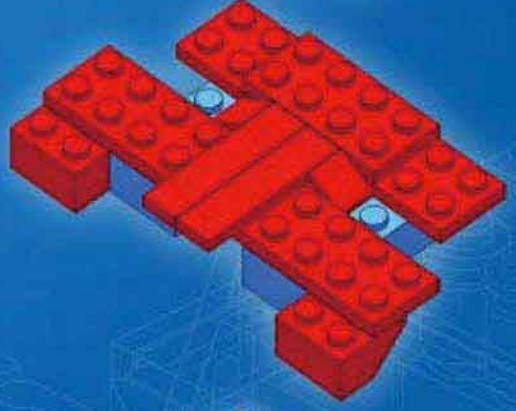

4

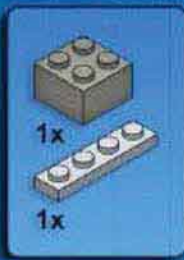
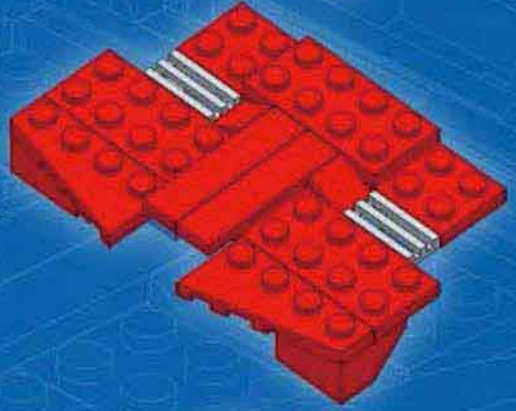

5

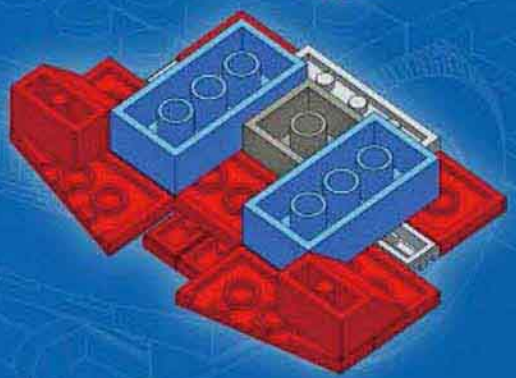

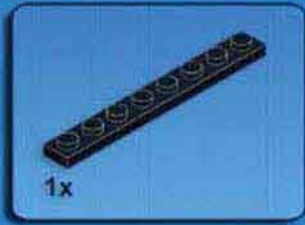

1x

6

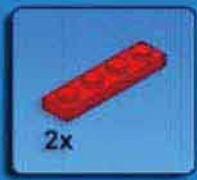
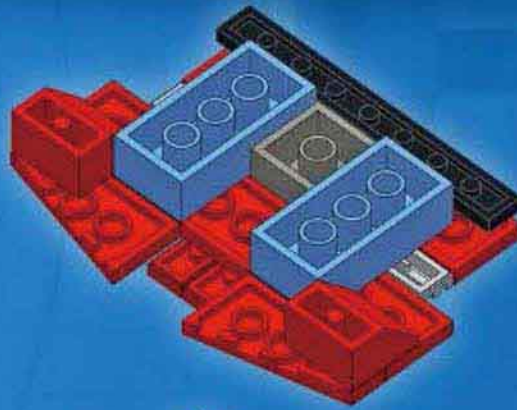

2x

7

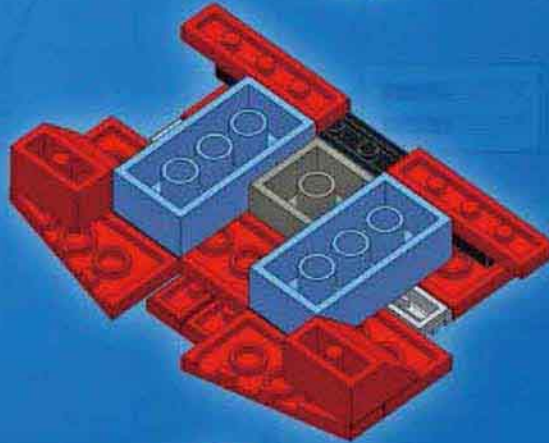

2x

2x

8

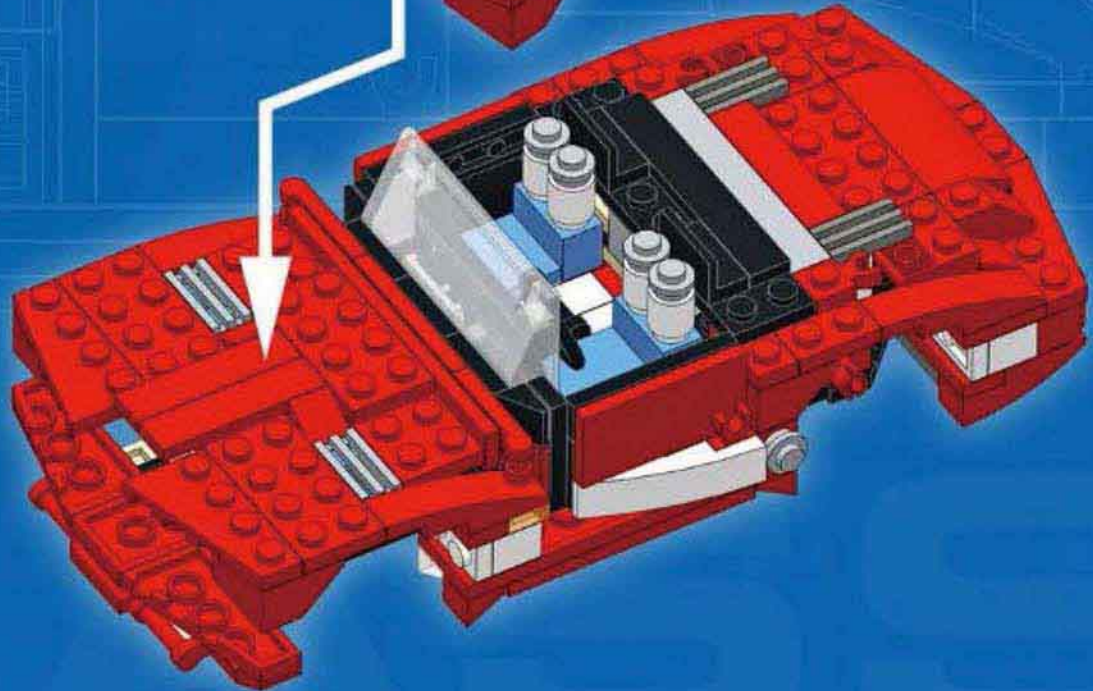
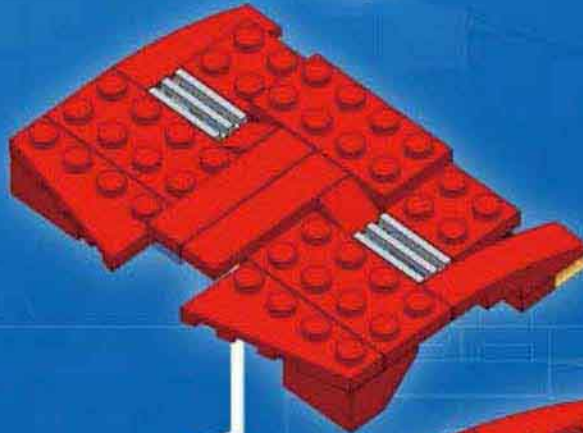



18

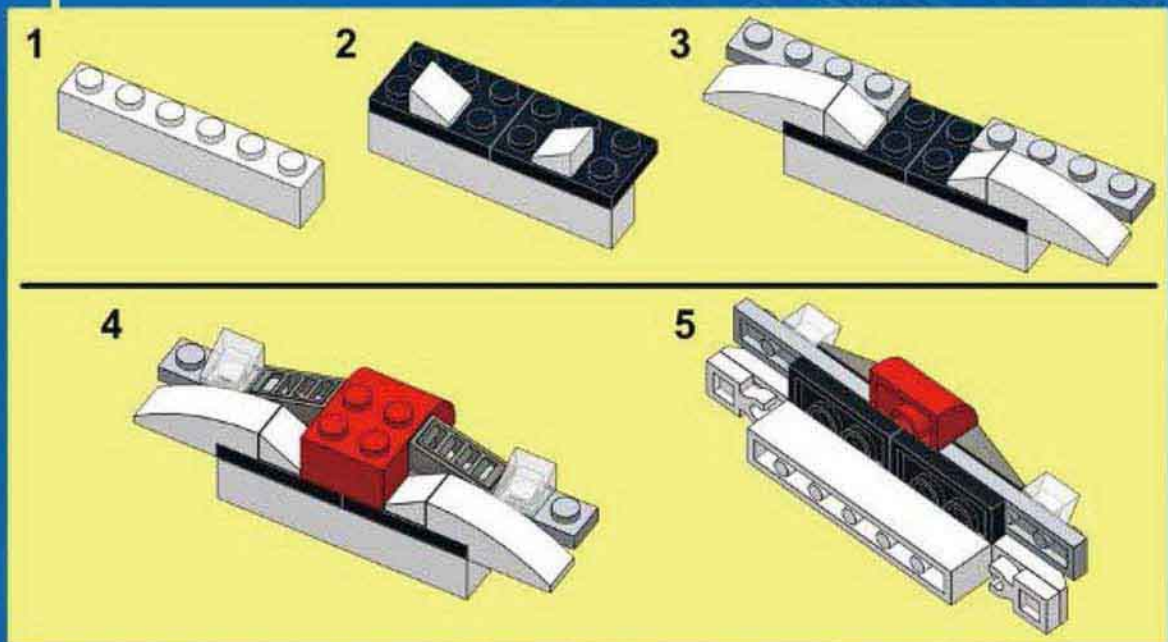
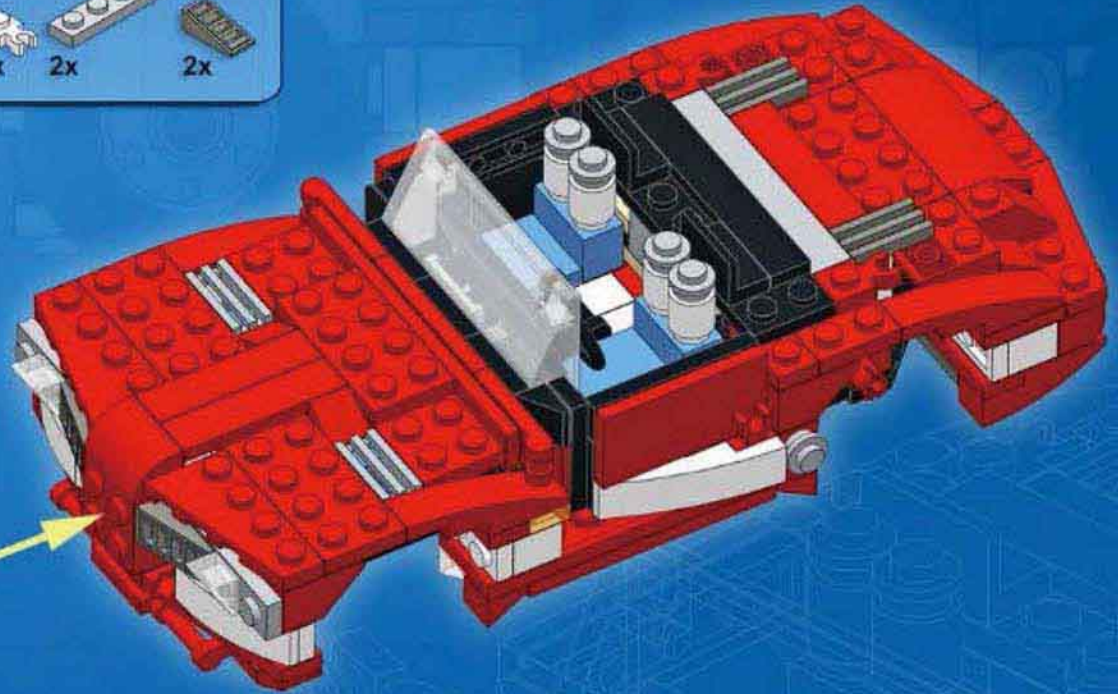
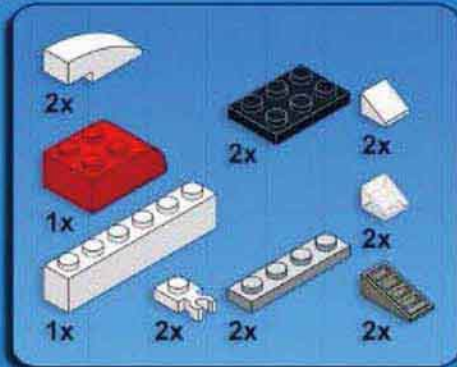



19

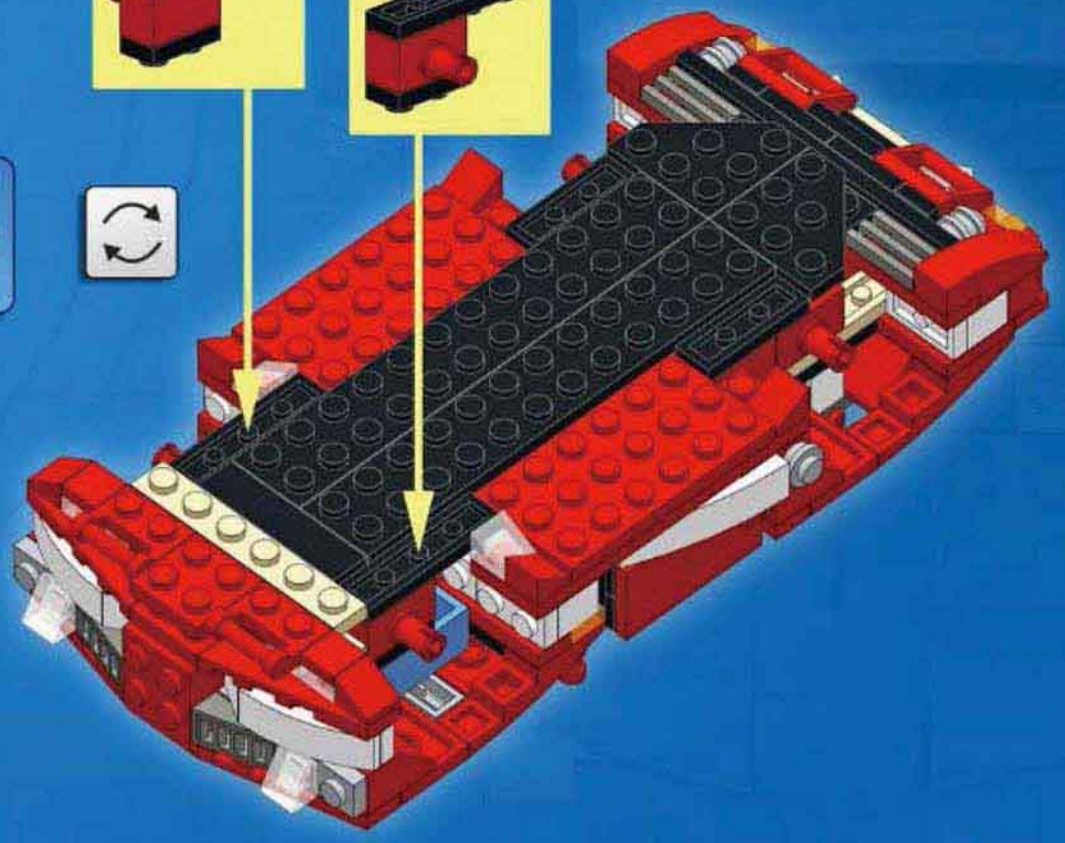
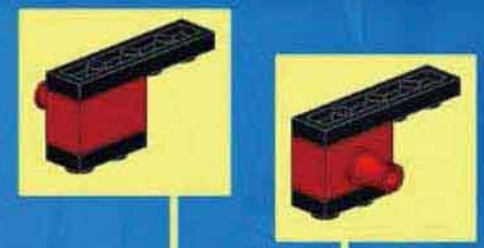
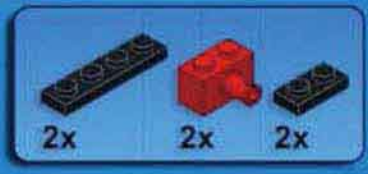

20

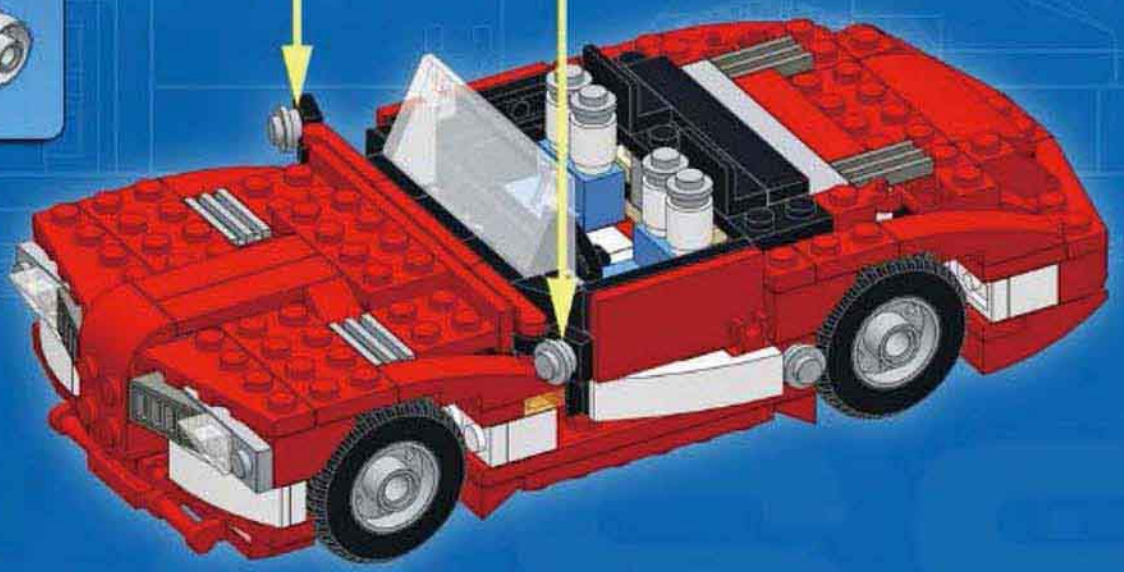



Complexity  
Functions  
Pieces

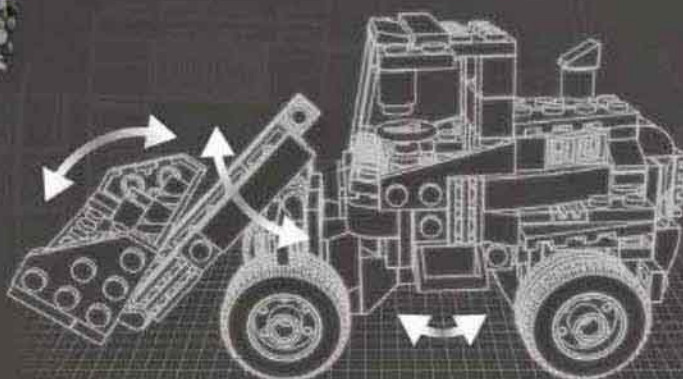

## WHEEL LOADER

Design notes: heavy-duty construction, central cabin

### Technical specifications:

Dimensions (l x w x h): 21 x 10 x 11 studs

Wheelbase: 9 studs

Axle width front/rear: 8/8 studs

Features: articulated steering, arm elevation, tipping bucket



1

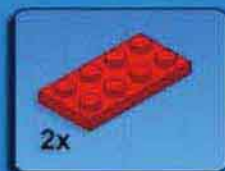

1

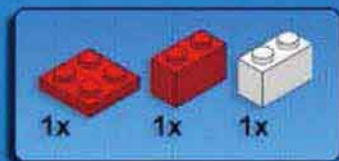
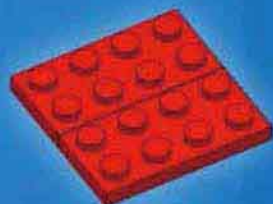

2

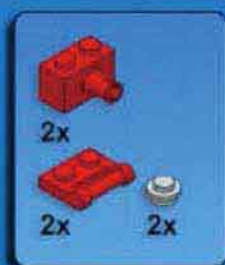

3

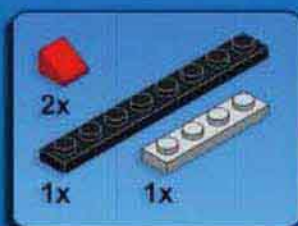
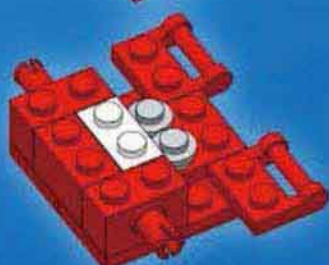

4

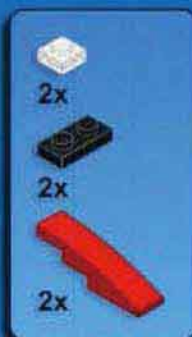
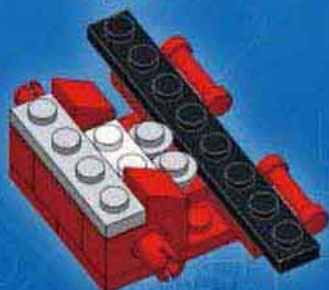

5

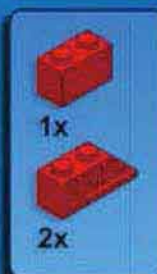
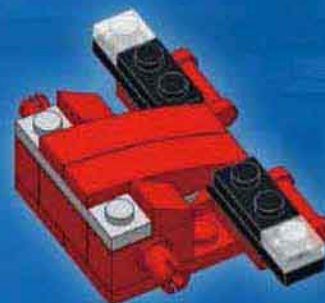

6

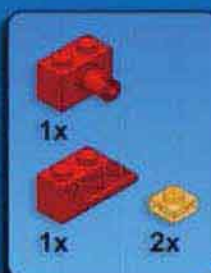
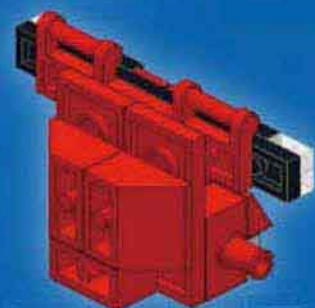

7

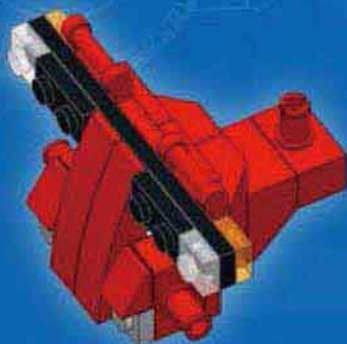
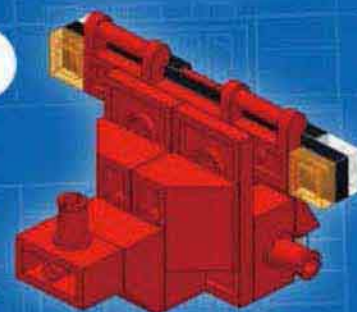

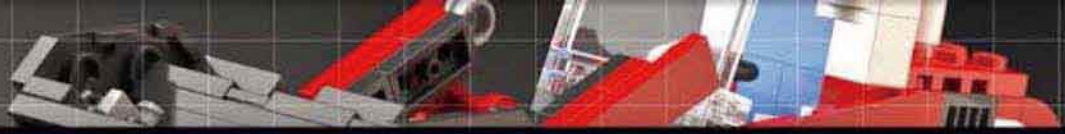

# 2

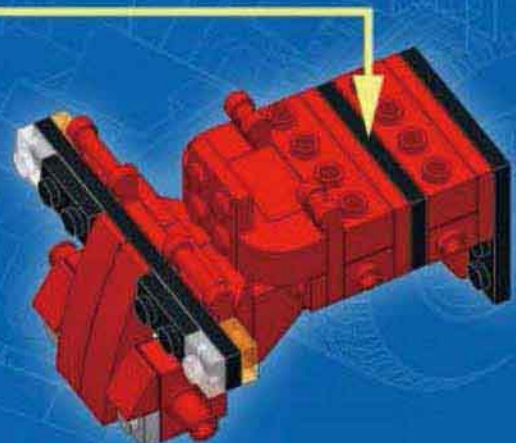
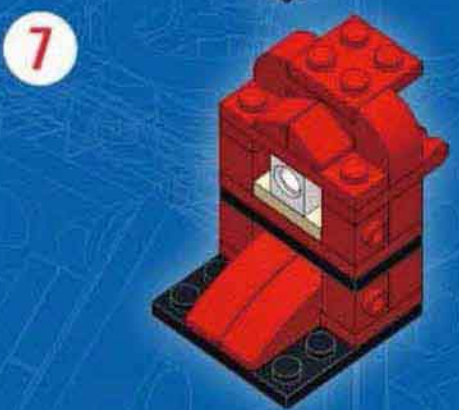
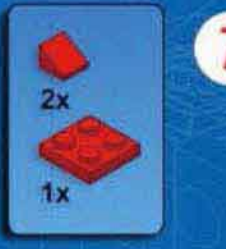
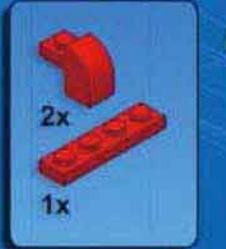
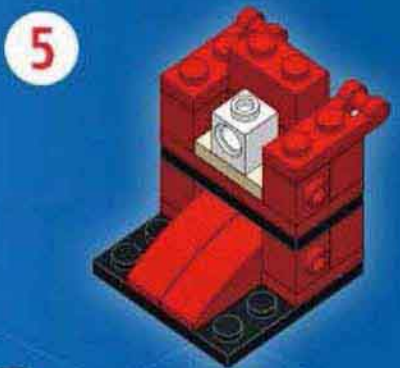
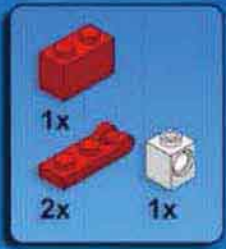
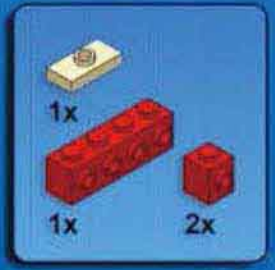
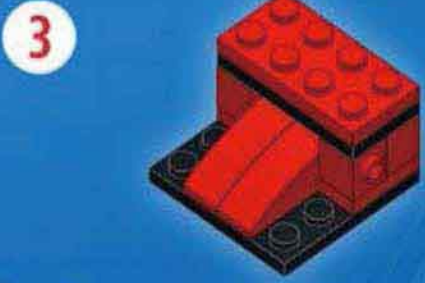
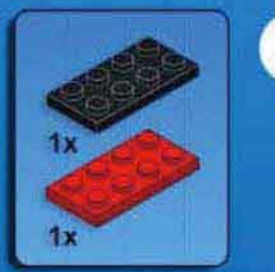
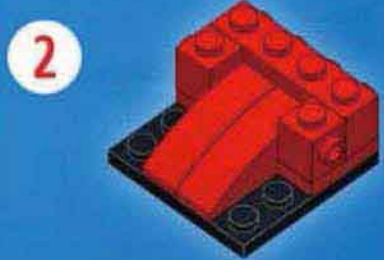
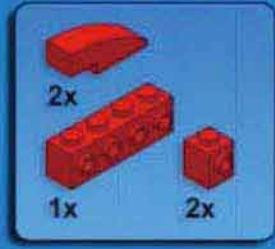
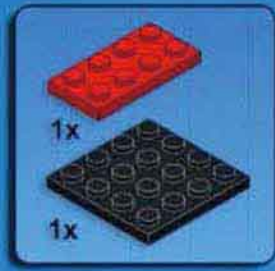



3

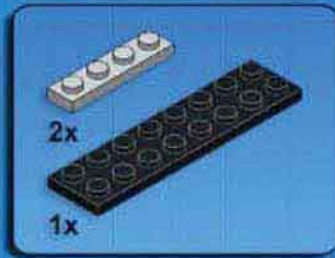

1

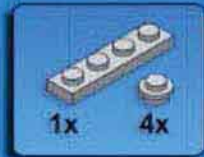

2

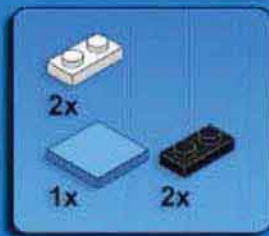
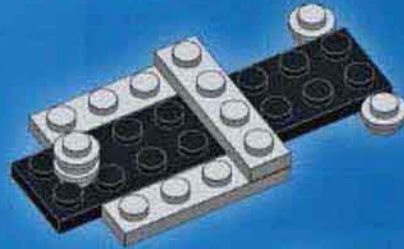

3

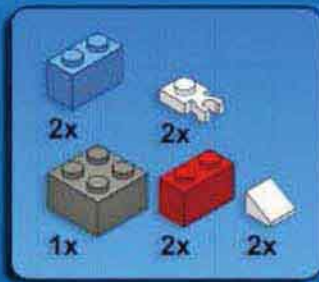
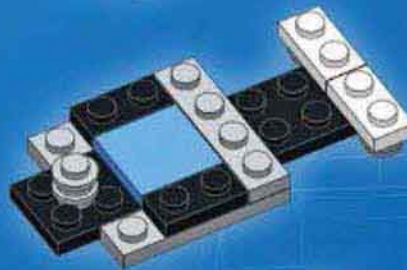

4

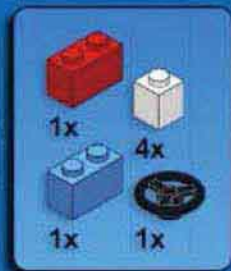
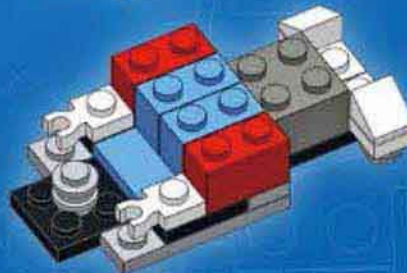

5

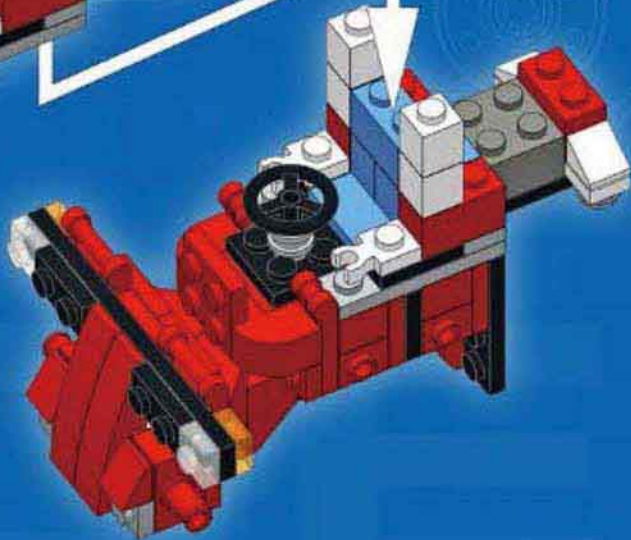
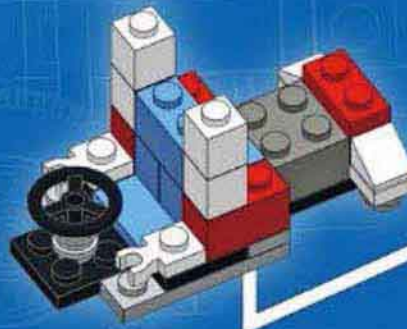



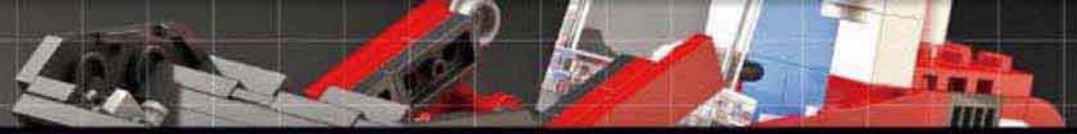

4

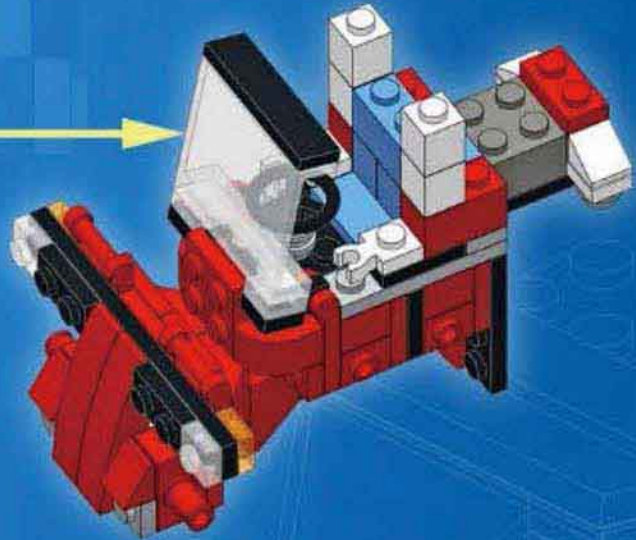
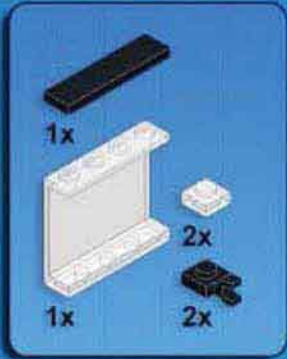

5

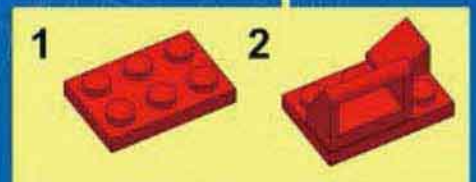
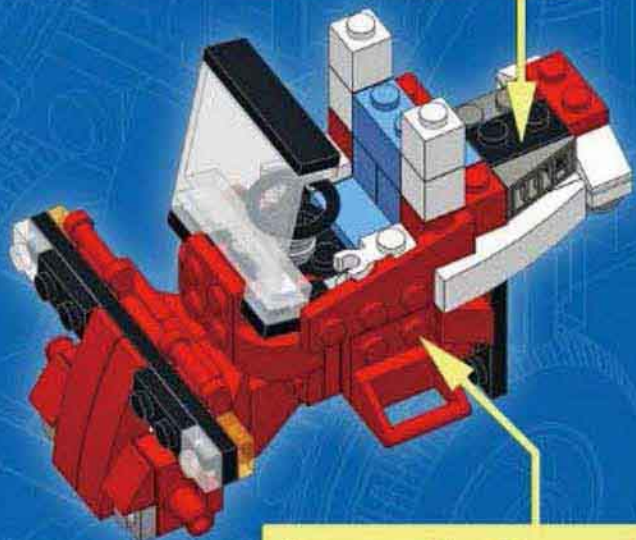
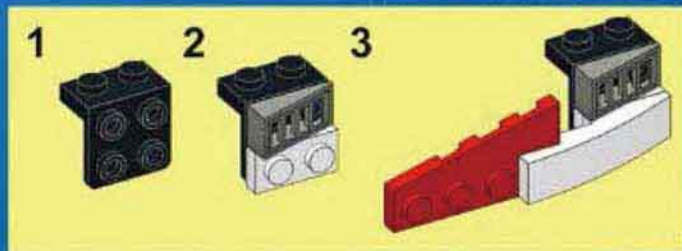
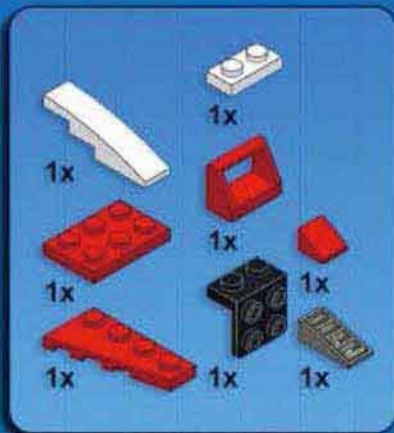

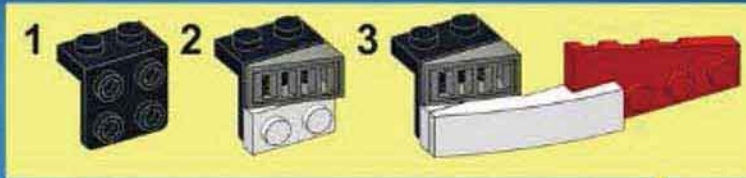

6

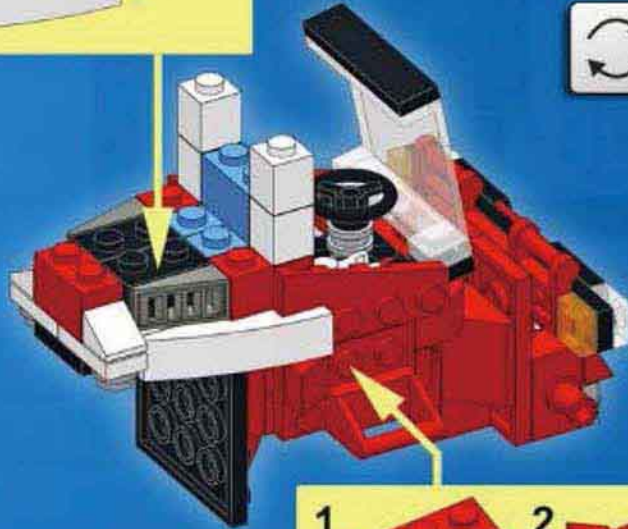
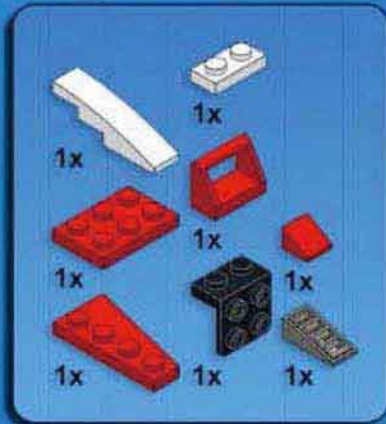

7

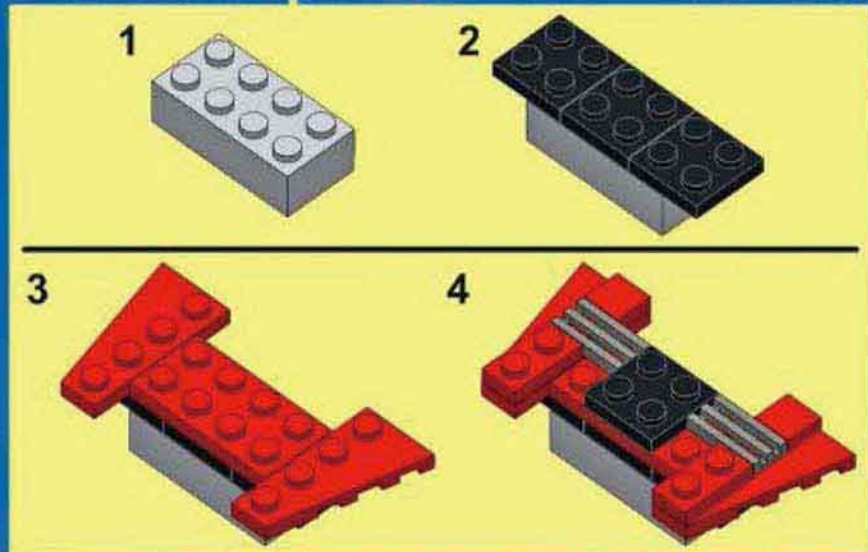
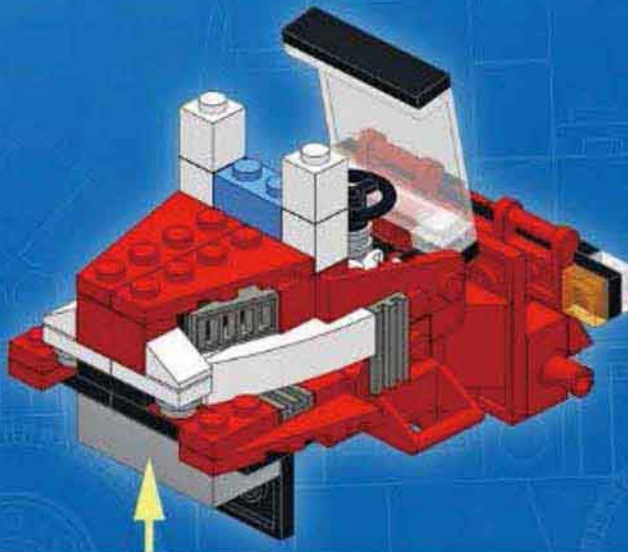
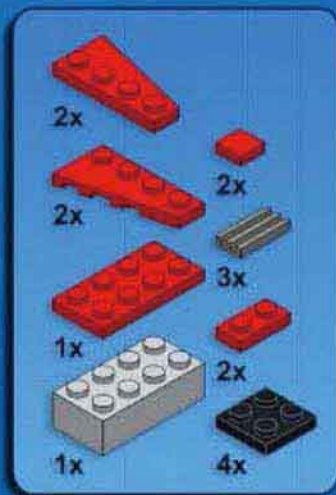



8

			2x
2x			2x
	2x		2x
1x			2x
	4x		2x
1x			2x
	2x		
	1x		

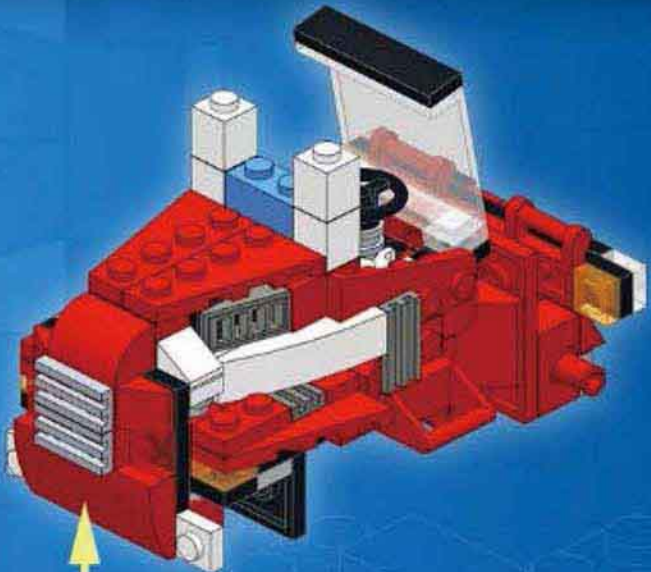

1

2

3

---

4

5

9

1x	
1x	
	2x

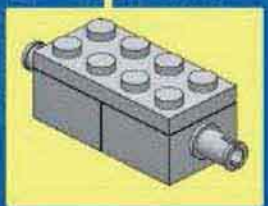
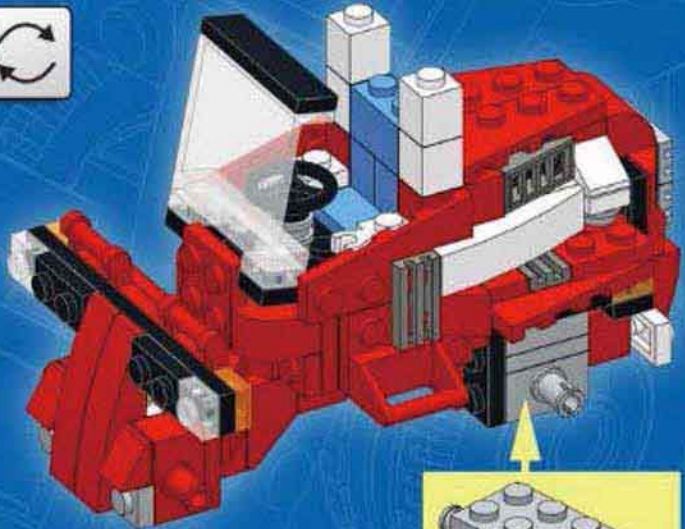



10

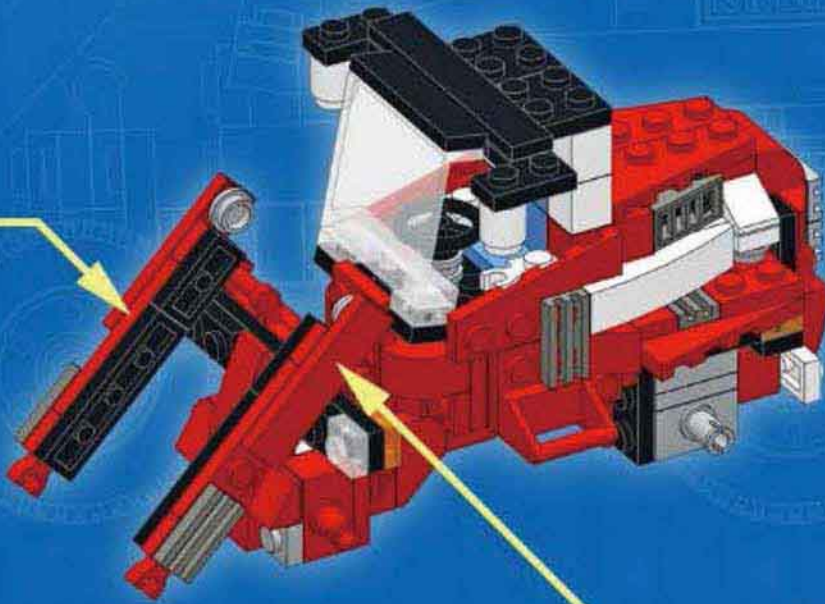
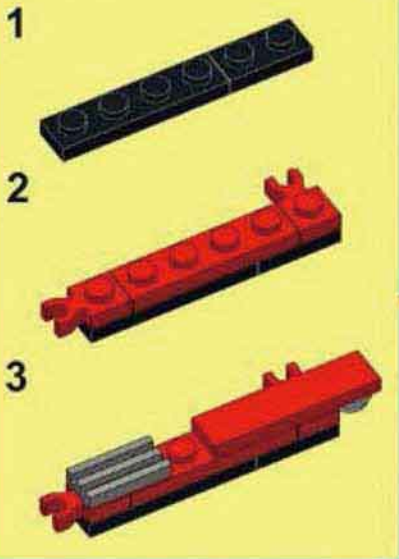
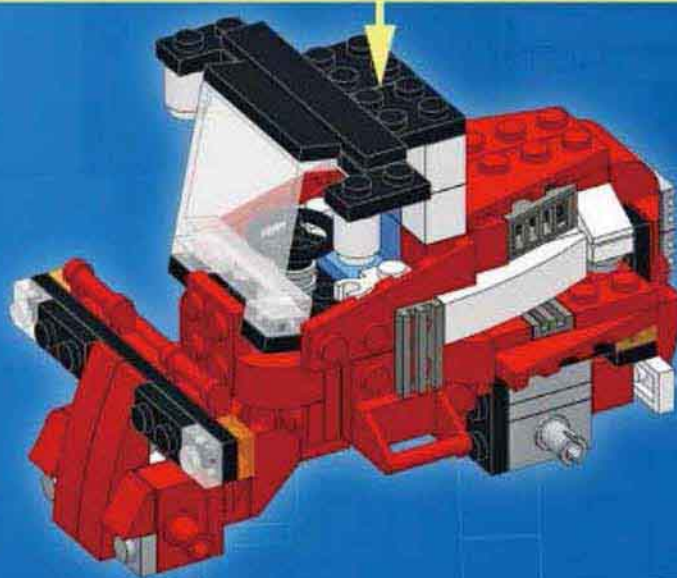
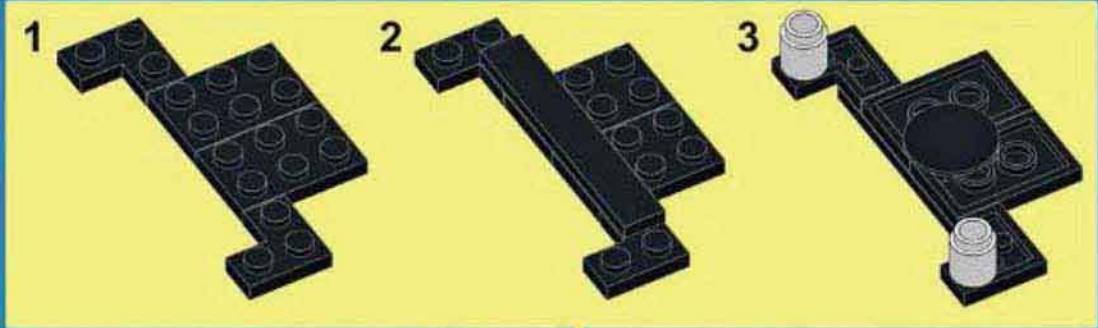
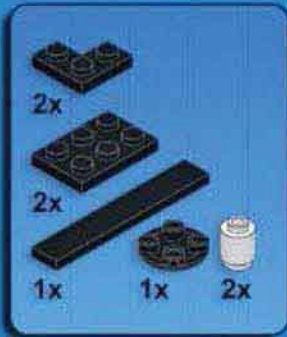

11

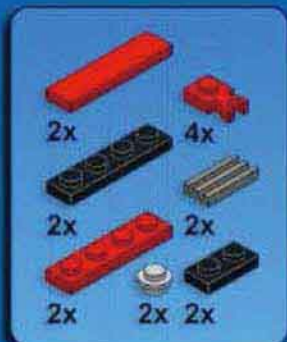



12

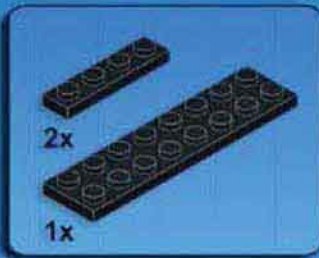

1

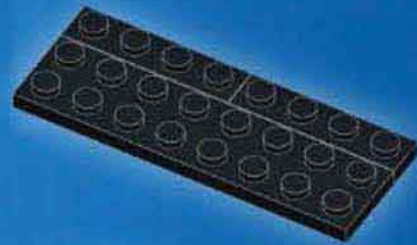

2



3

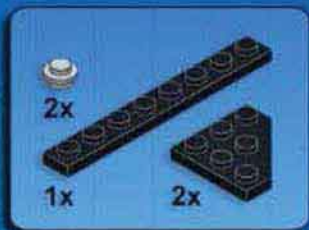
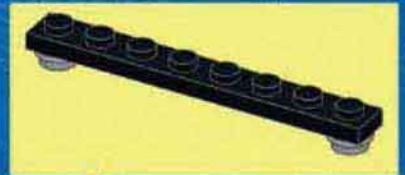
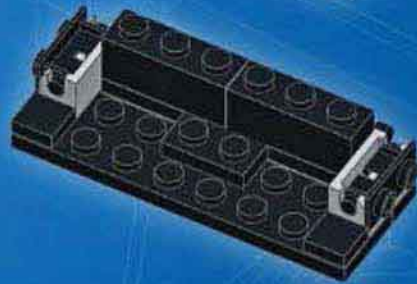

4

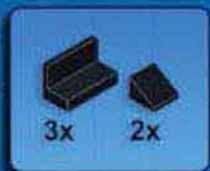
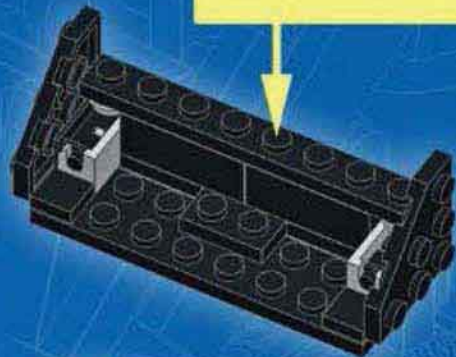

5





13



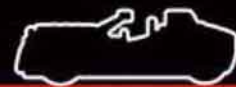

Complexity   
Functions   
Pieces 

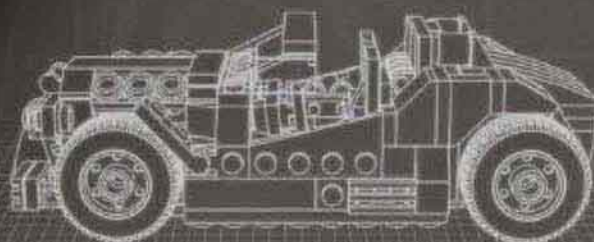
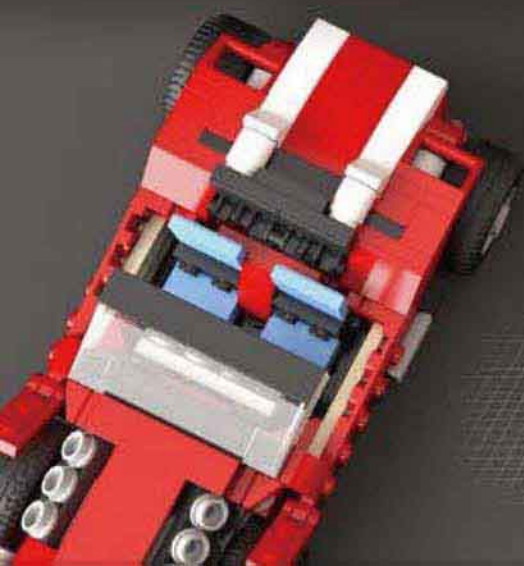

## STREET ROD

Design notes: wide rear axle, lowrider, exposed V6 engine, detailed two-seat interior

### Technical specifications:

Dimensions (l x w x h): 19 x 10 x 6 studs  
Wheelbase: 12 studs  
Axle width front/rear: 9/10 studs

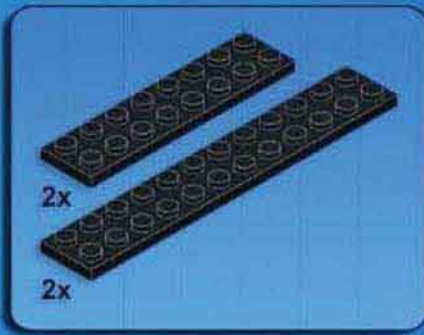
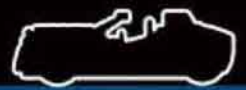

1

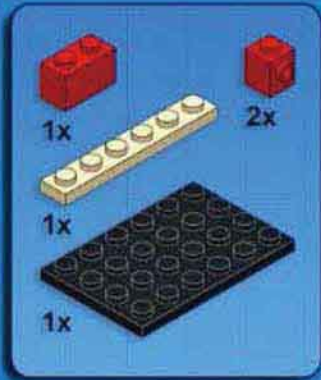

2

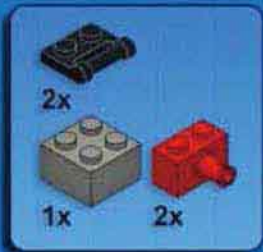

3

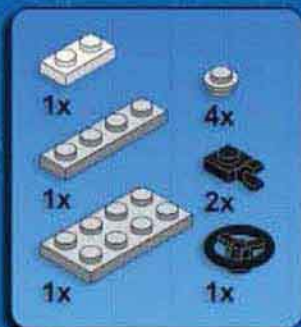
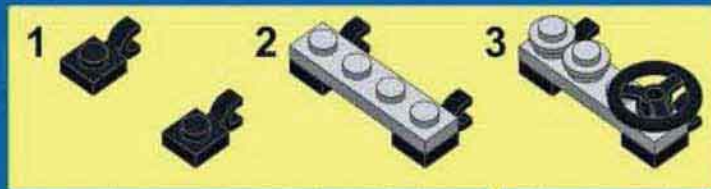
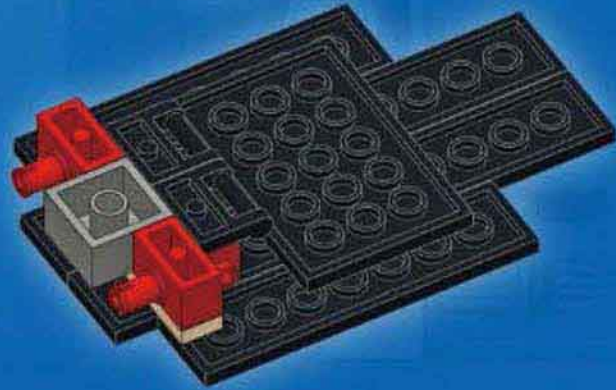

4





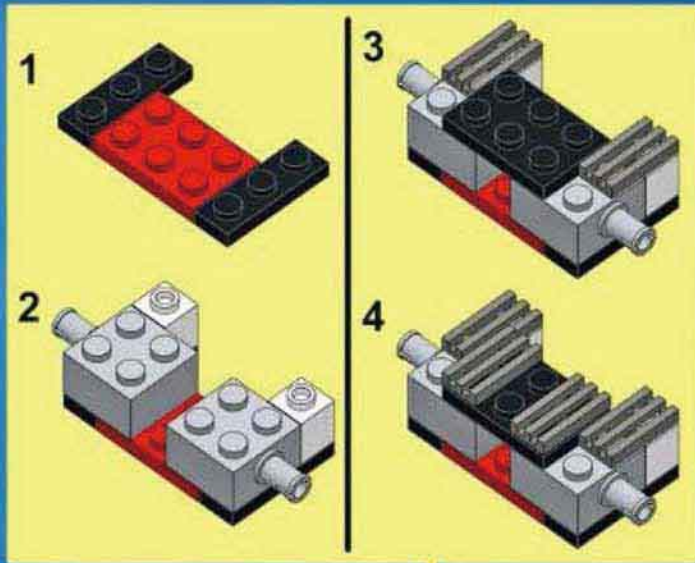

5

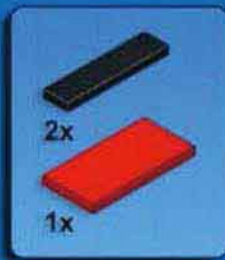
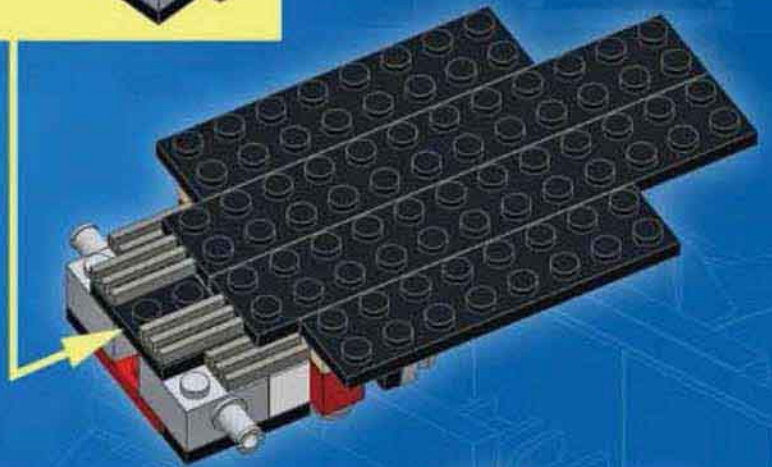

6

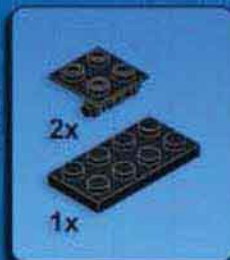
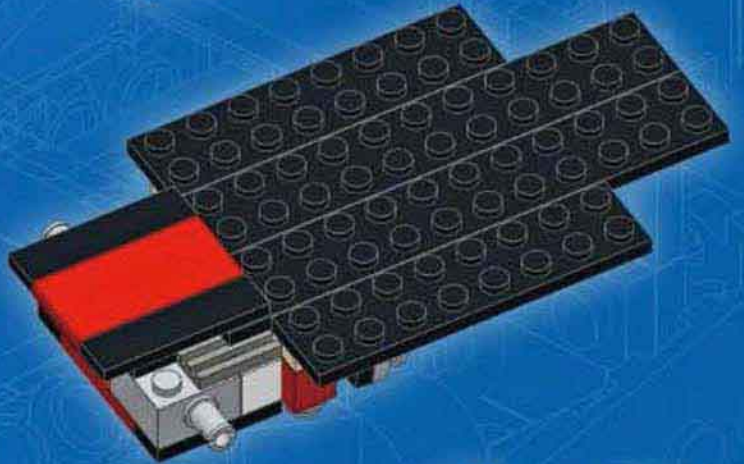

7

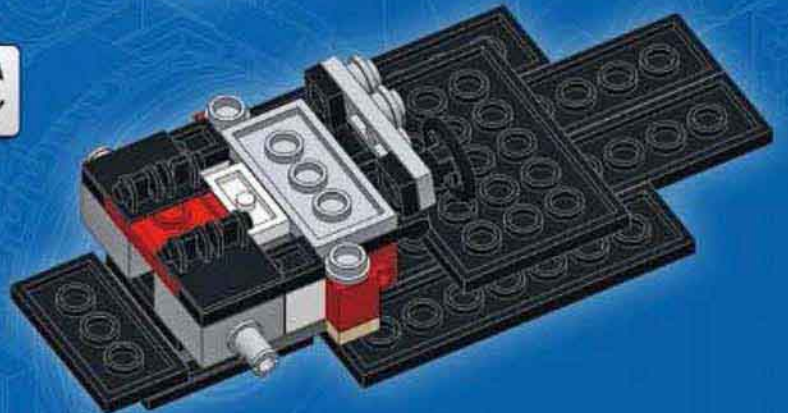

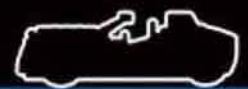

8

- 2x
- 1x
- 2x
- 3x
- 1x

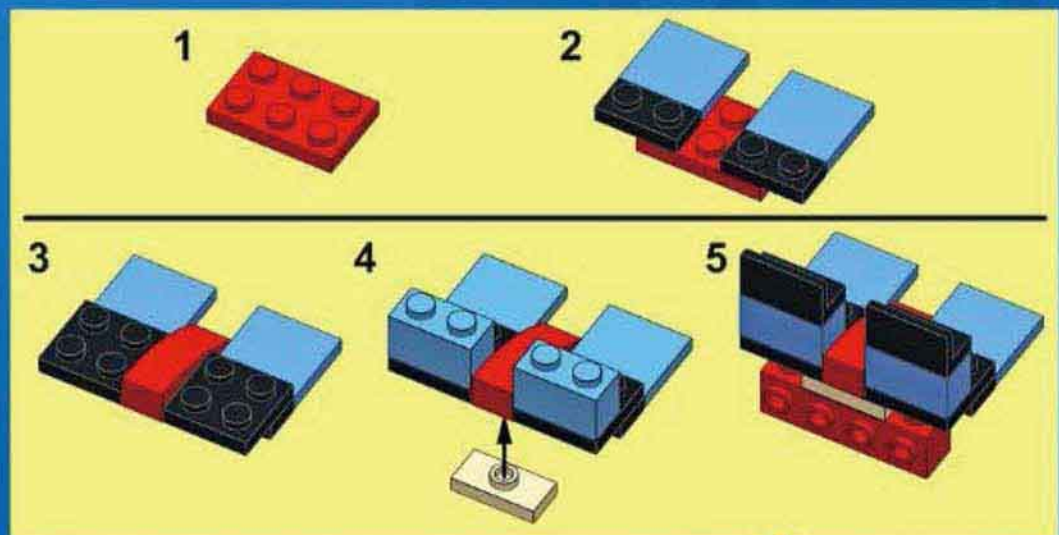
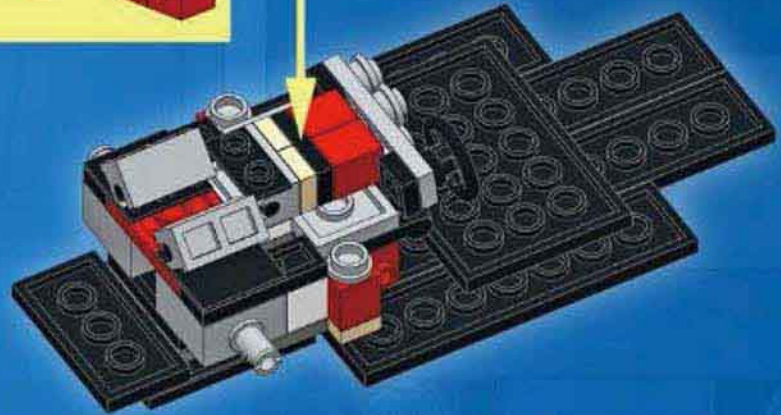
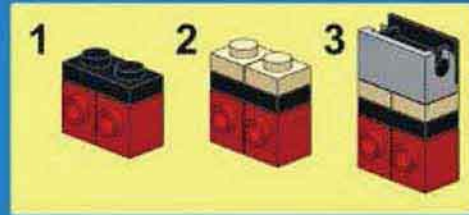

9

- 1x
- 2x
- 2x
- 1x
- 2x
- 1x
- 1x
- 2x
- 2x
- 2x

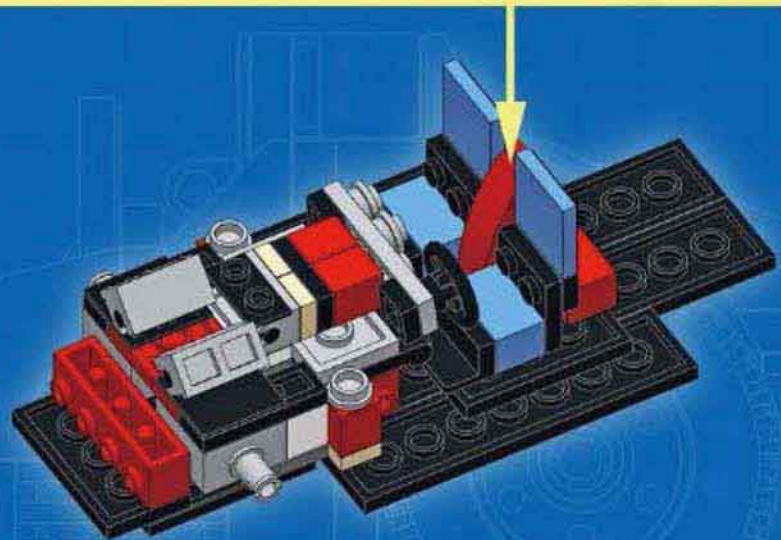

10



1

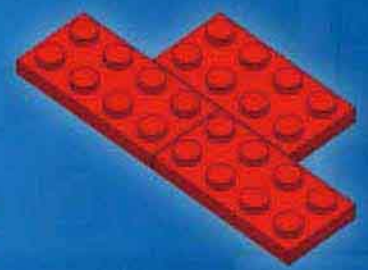

2

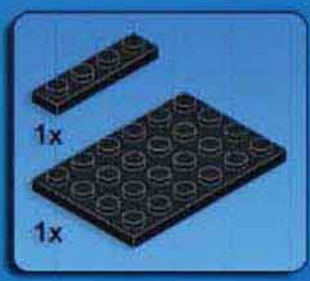

3

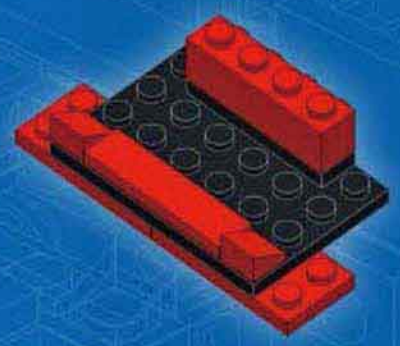
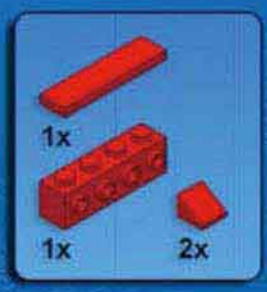

4

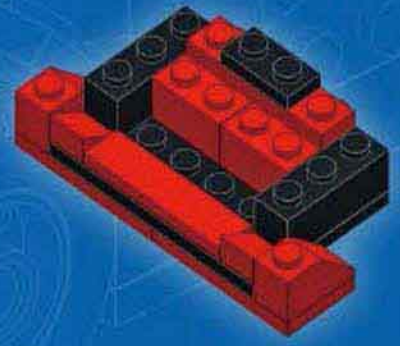
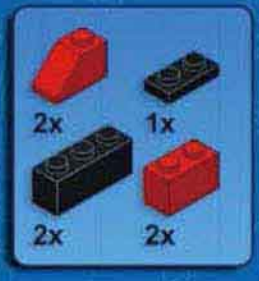

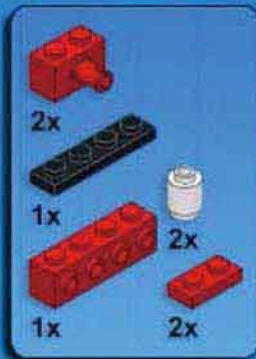
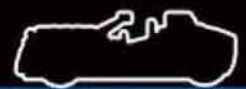

5

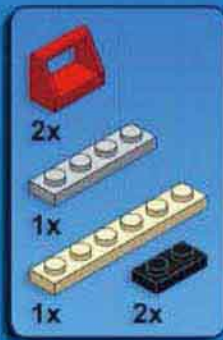
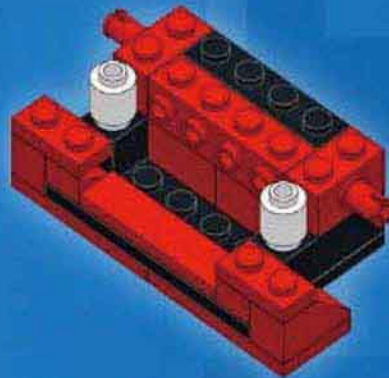

6

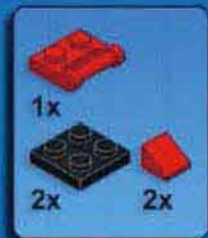
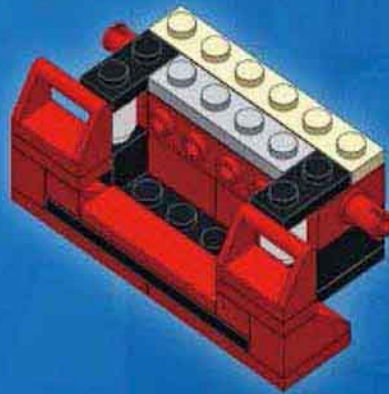

7

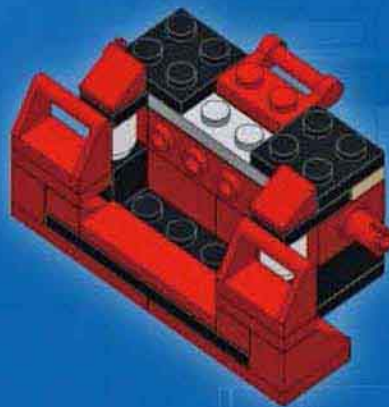

8

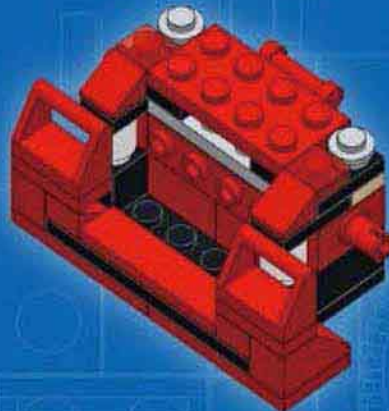

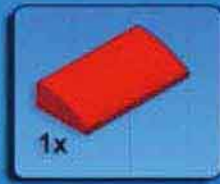

9

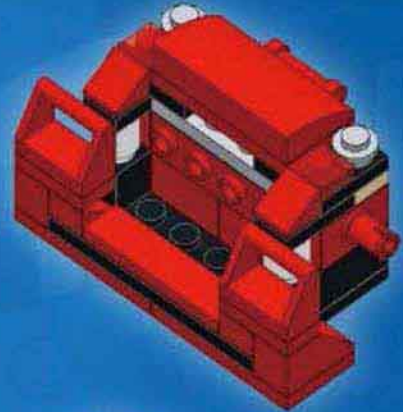

10

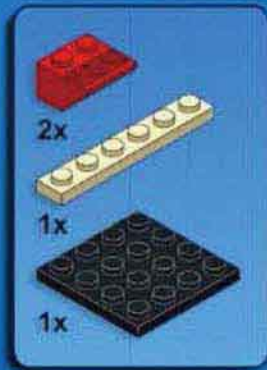
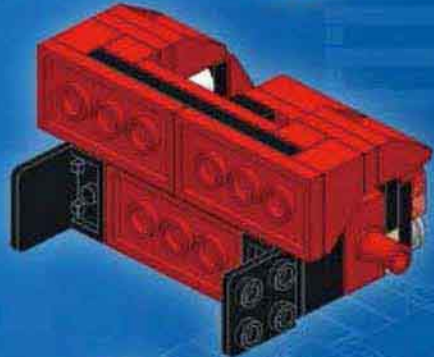

11

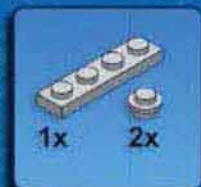
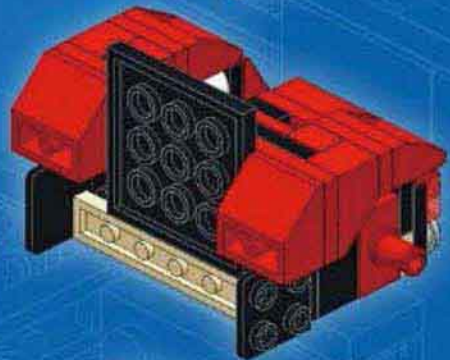

12

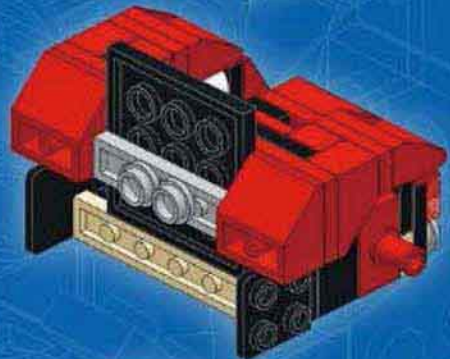

13

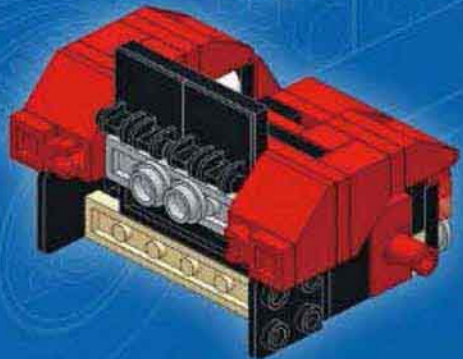

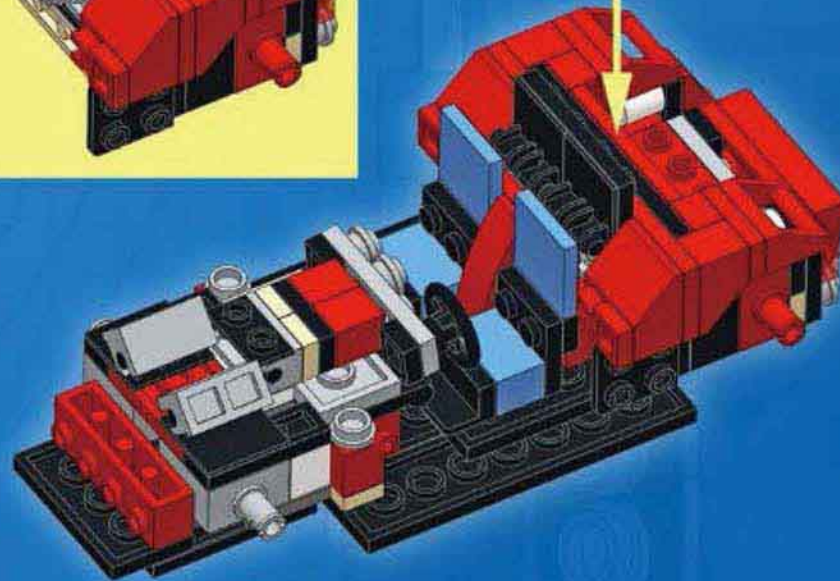
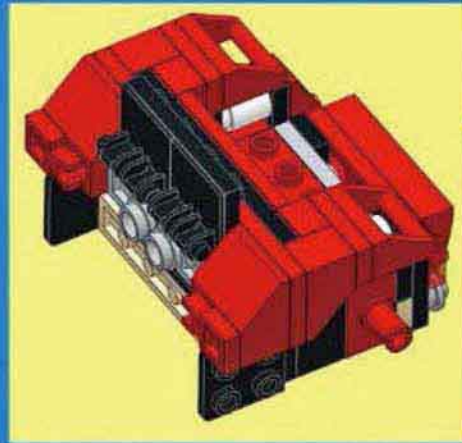
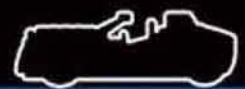

11

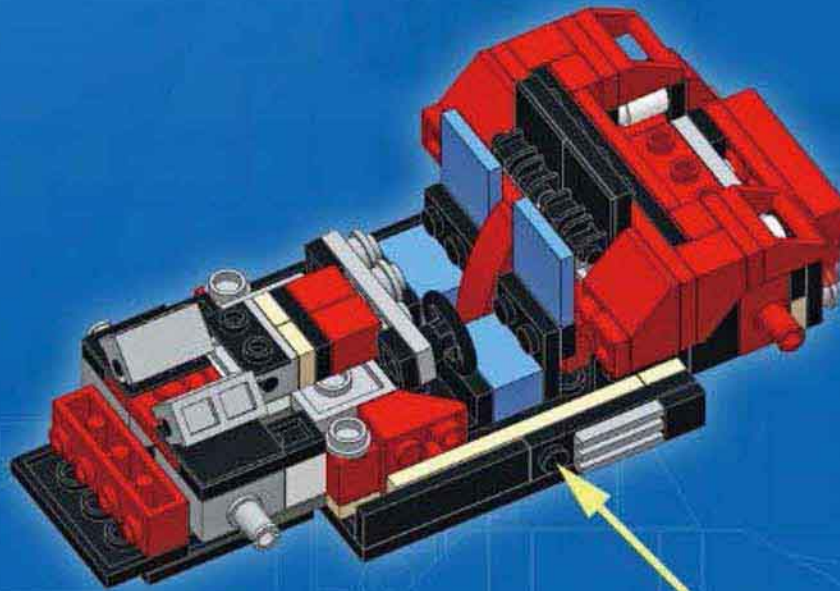
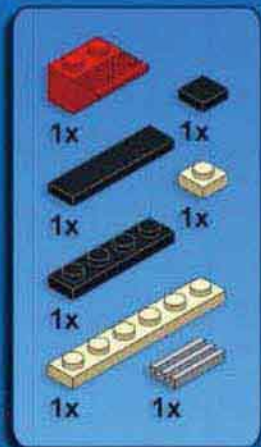

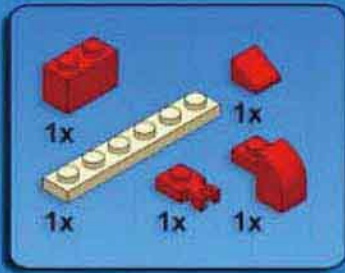

12

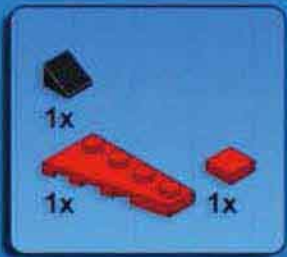
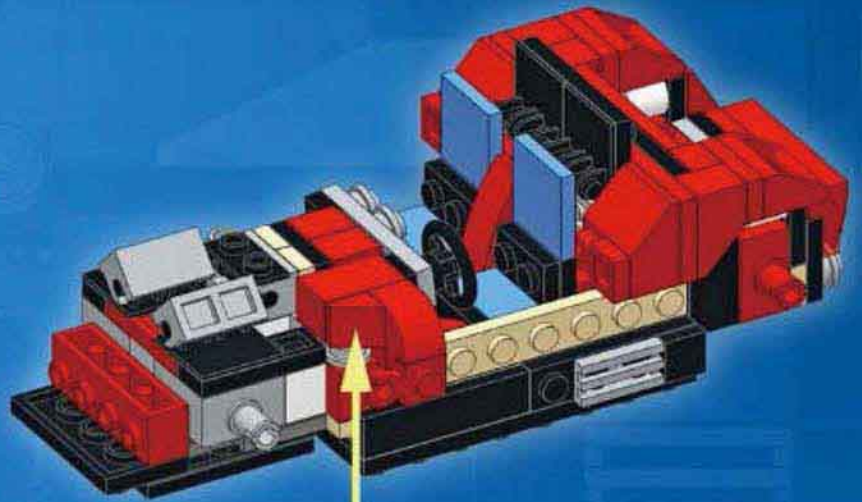
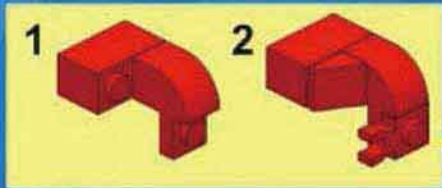

13

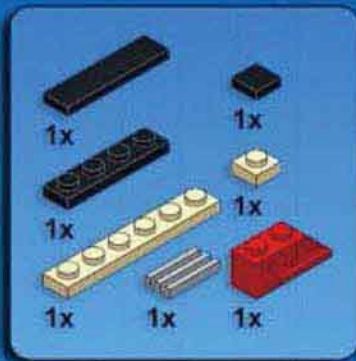
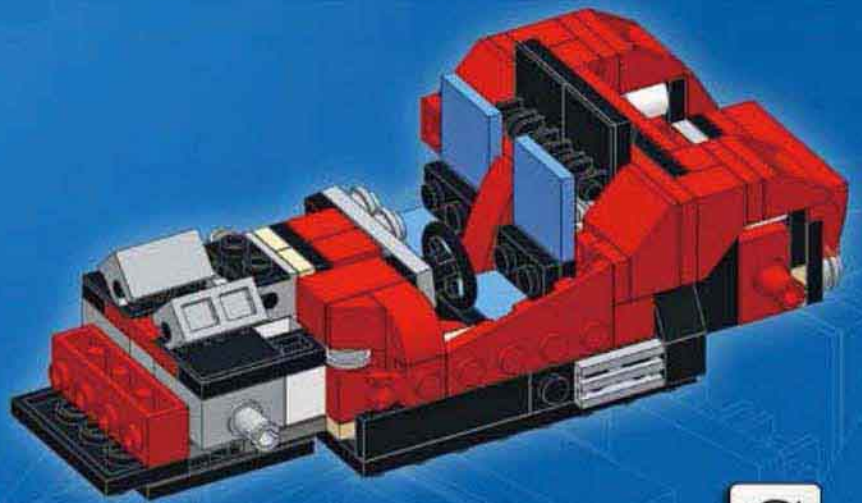

14

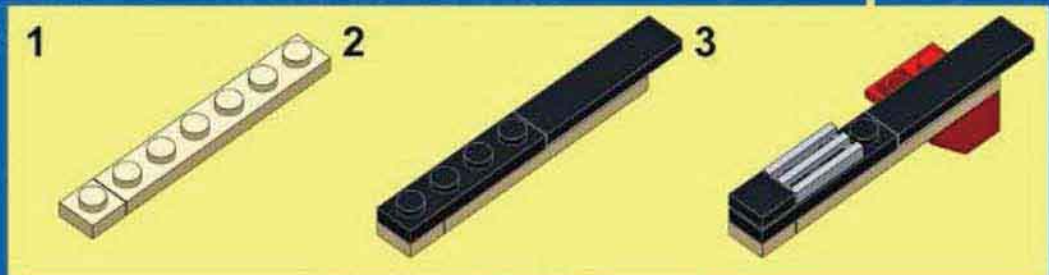

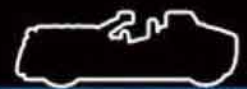

15

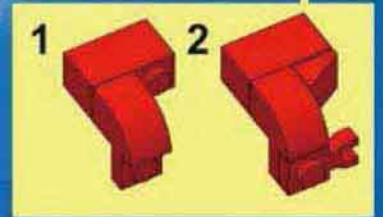
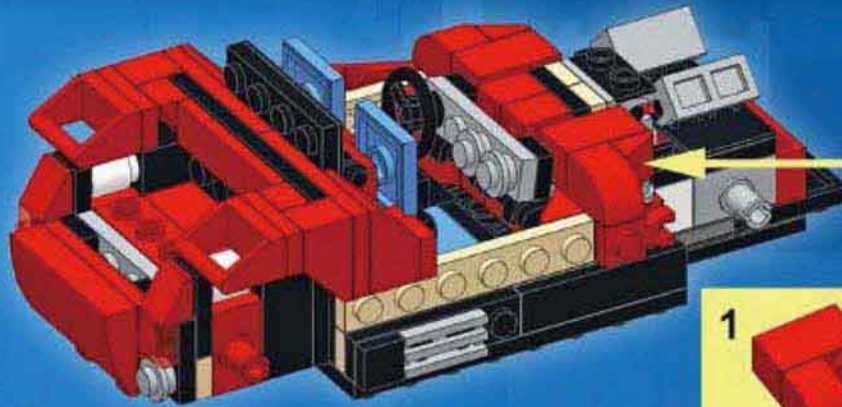
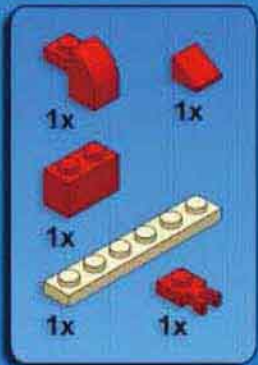

16

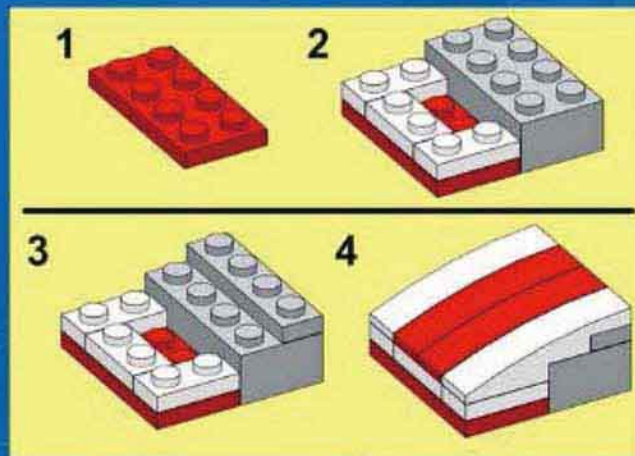
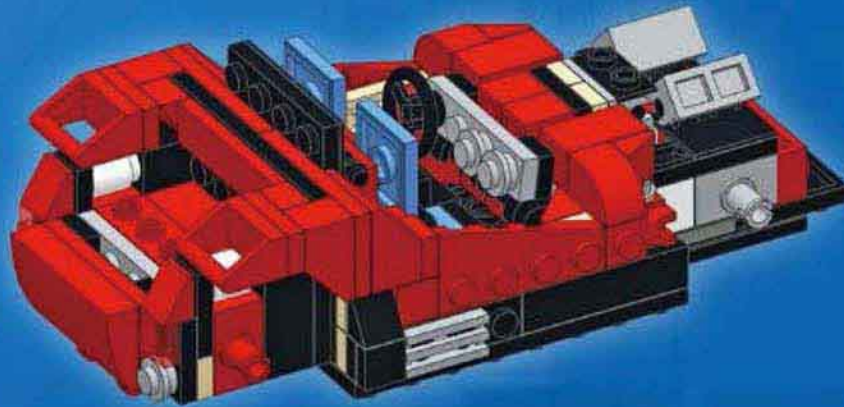

17

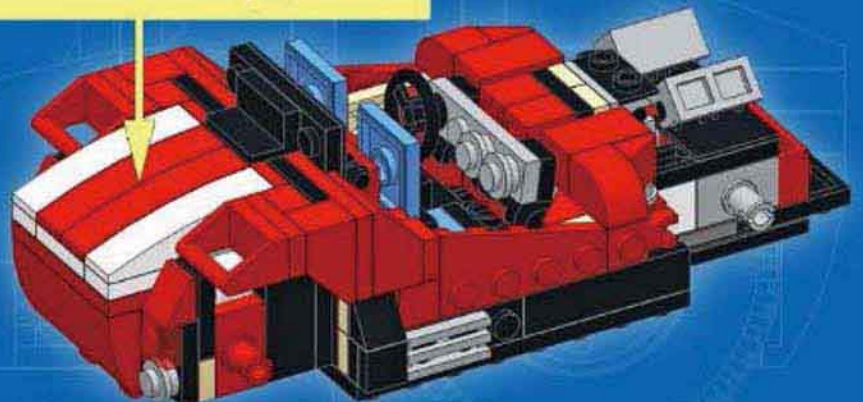
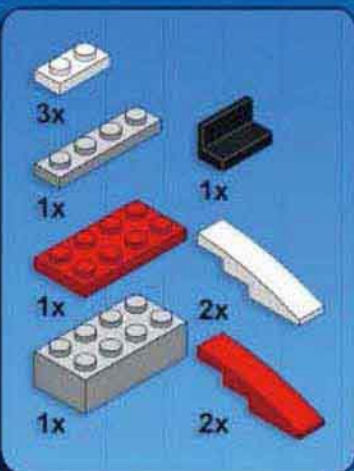





18

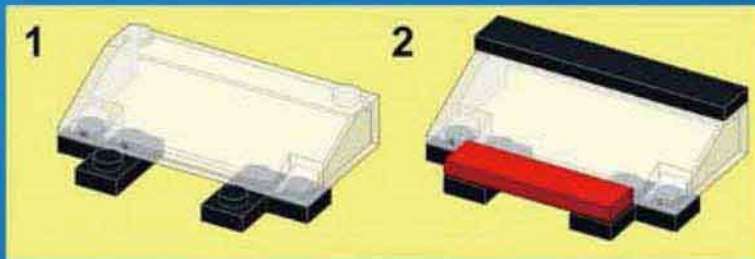
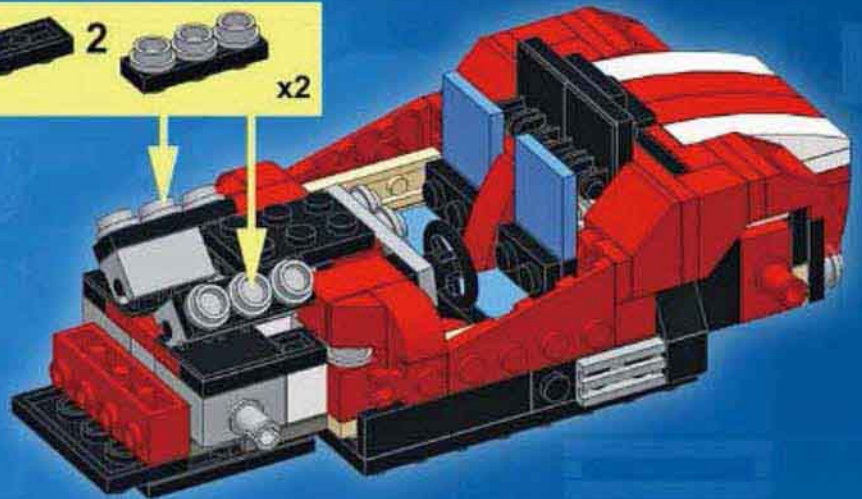

19

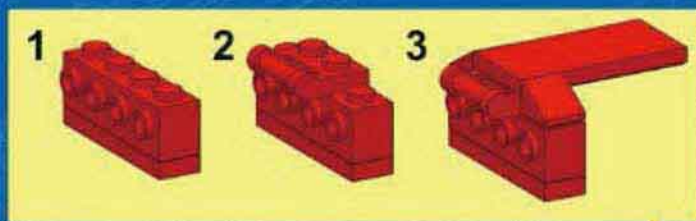
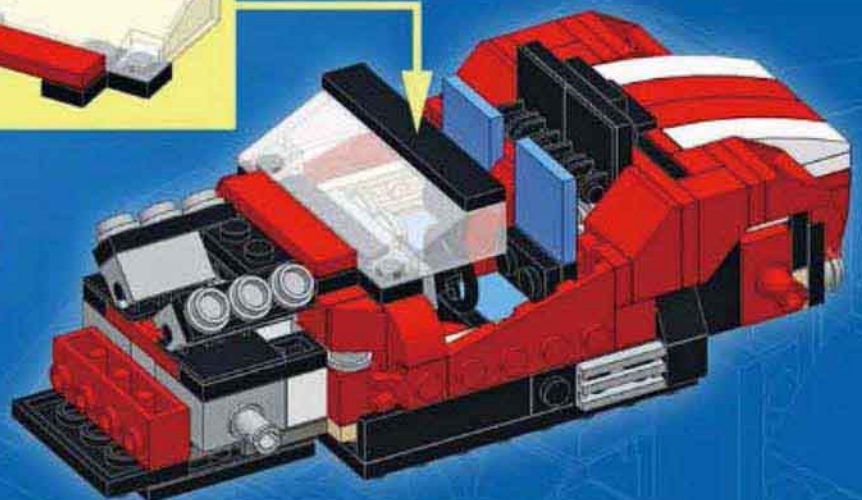
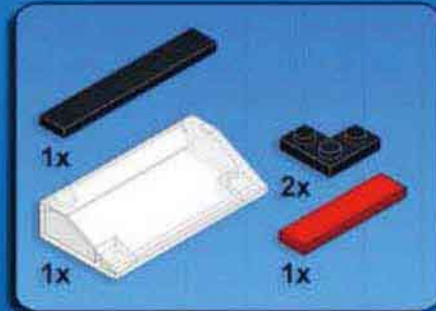

20

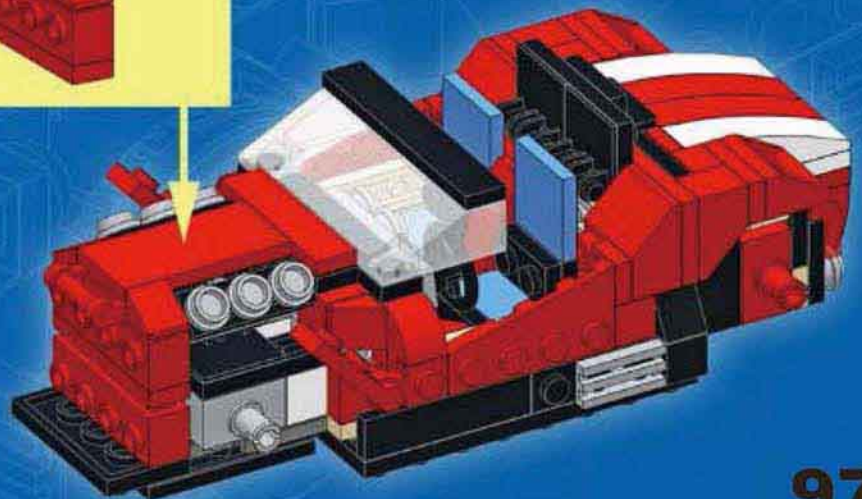
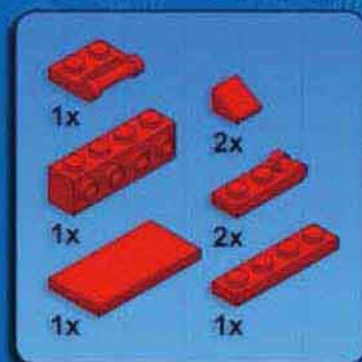

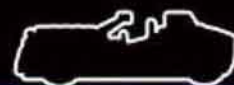

21

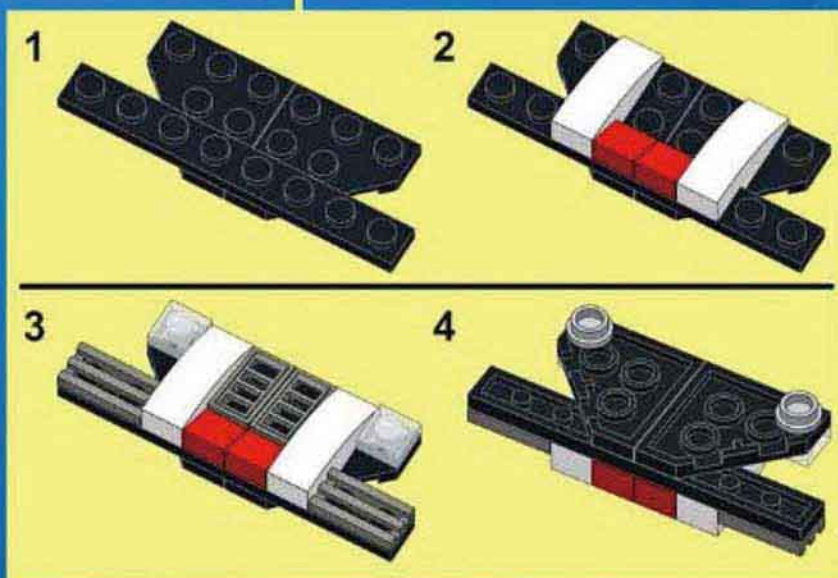
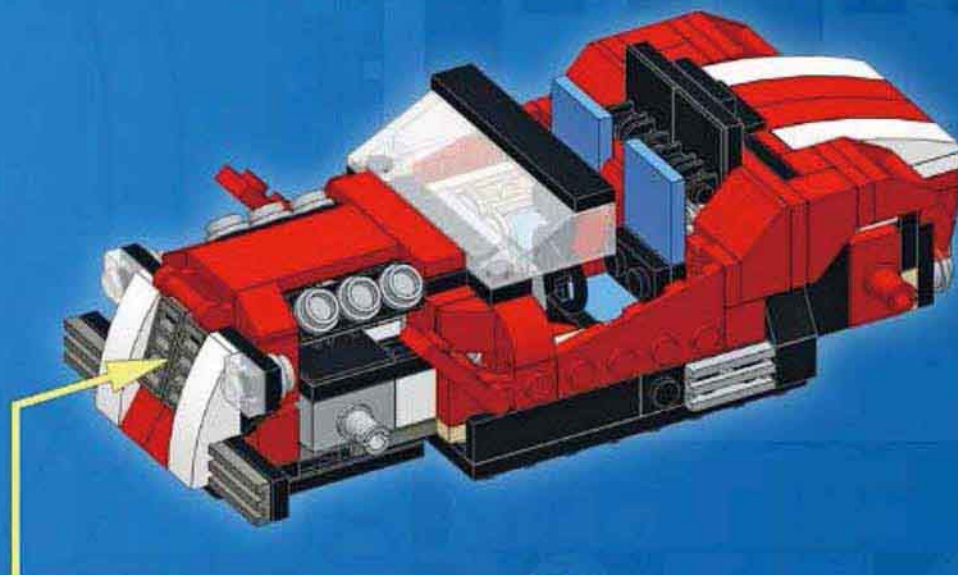
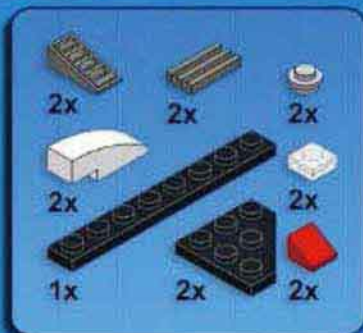

22

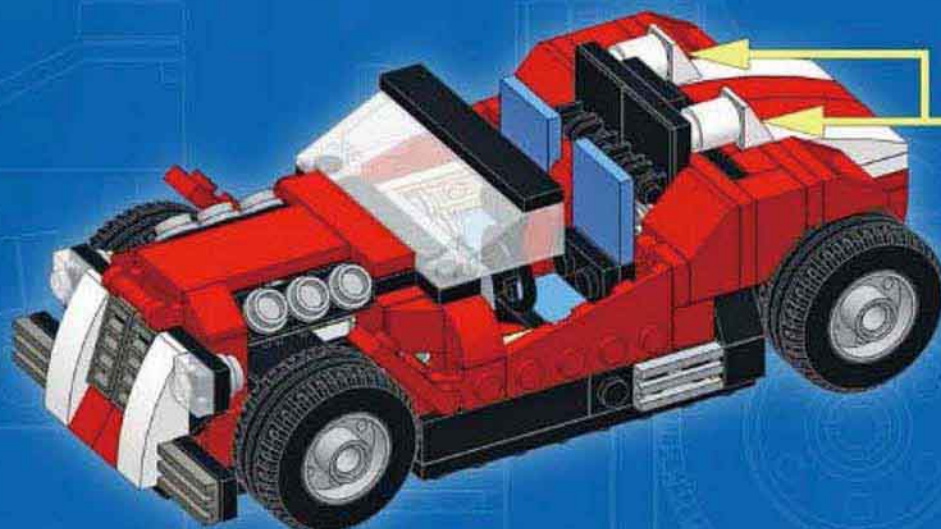



Complexity 

Functions 

Pieces 

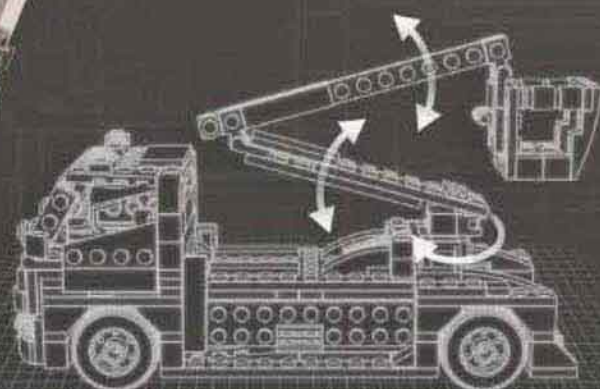
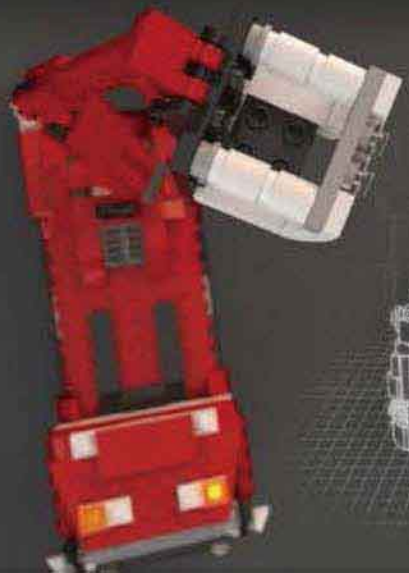
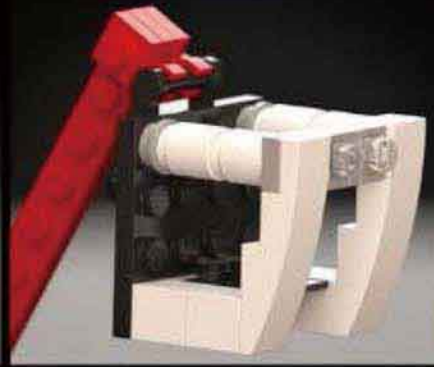

## RESCUE TRUCK

Design notes: long wheelbase, cherry picker arm with bucket, massive front grille, hazard lights

Technical specifications:  
 Dimensions (l x w x h): 26 x 10 x 11 studs  
 Wheelbase: 16 studs  
 Axle width front/rear: 8/8 studs

Features: boom rotation, boom elevation

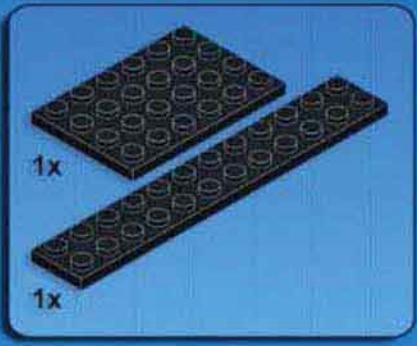

1

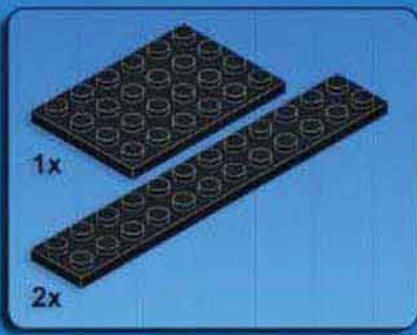

2

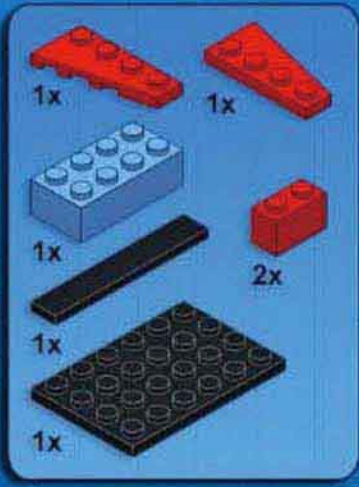
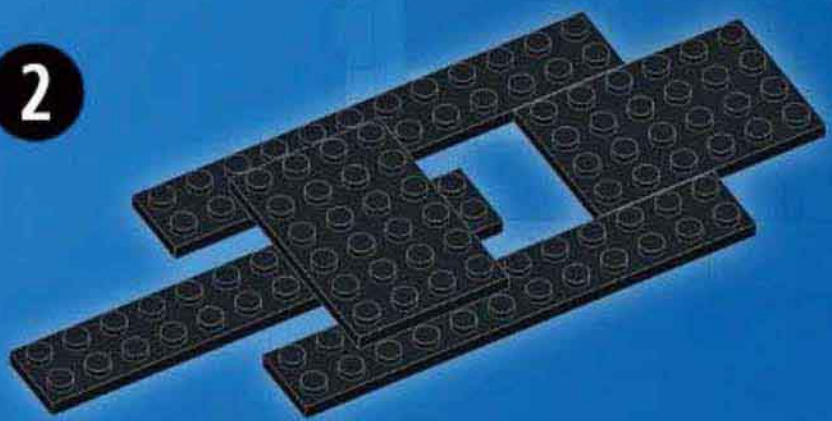

3

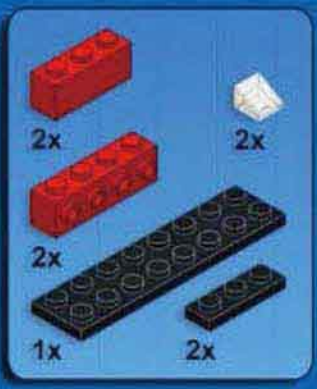
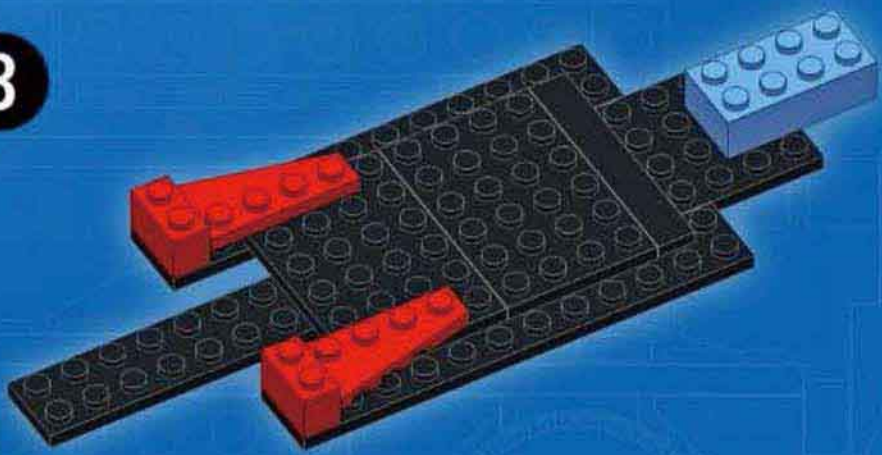

4



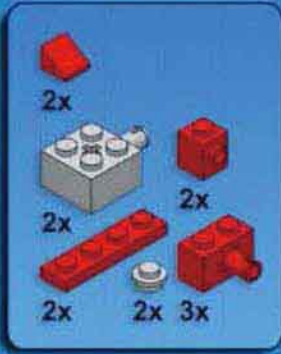

5

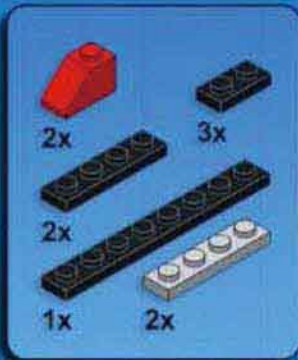
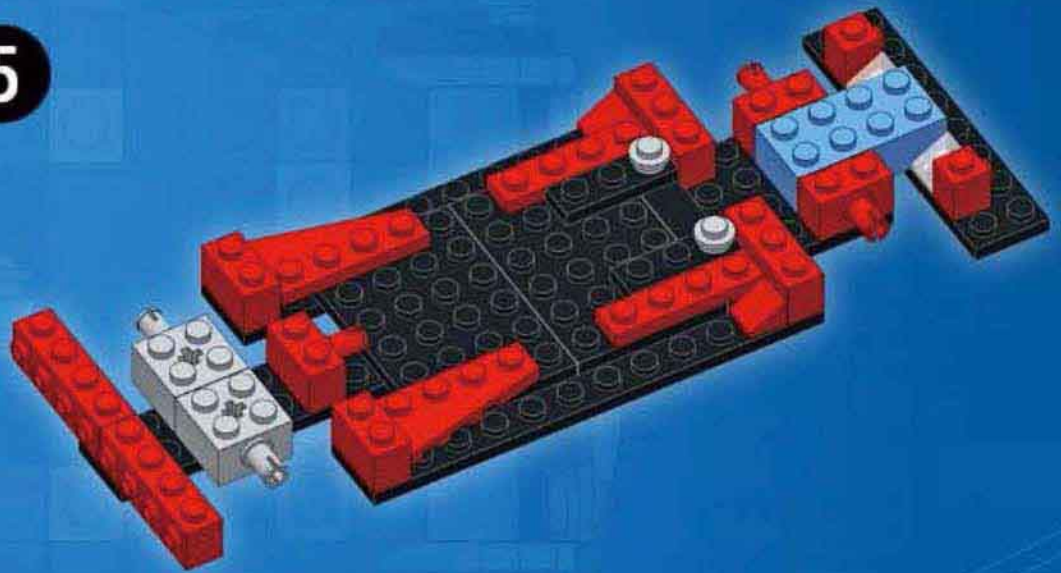

6

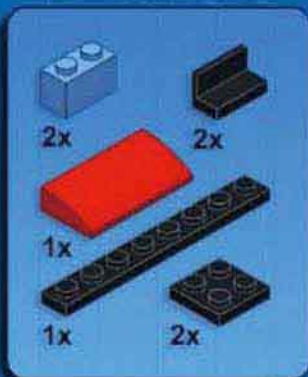

7

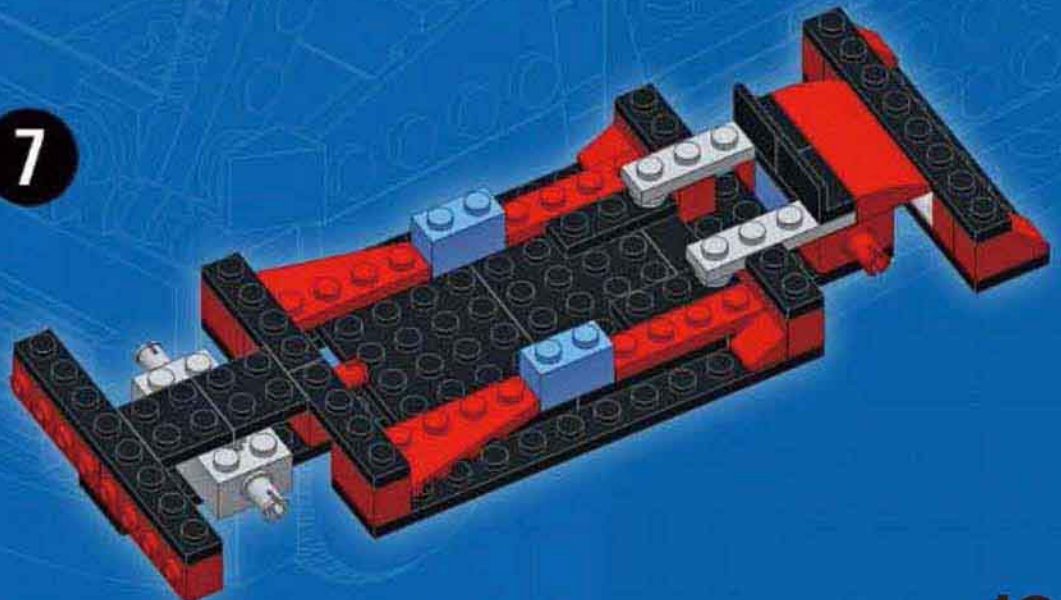



8

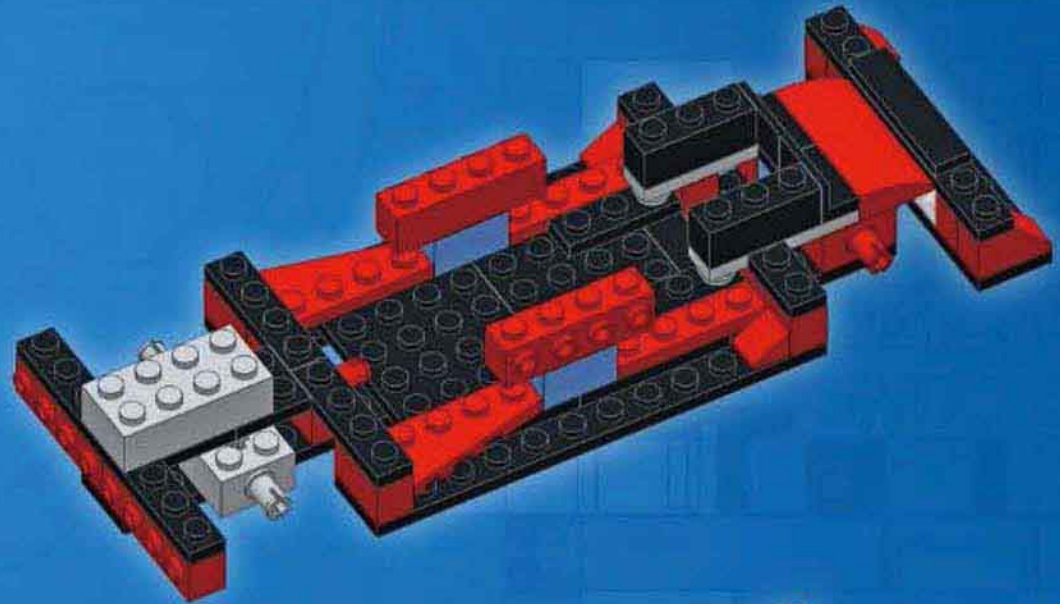
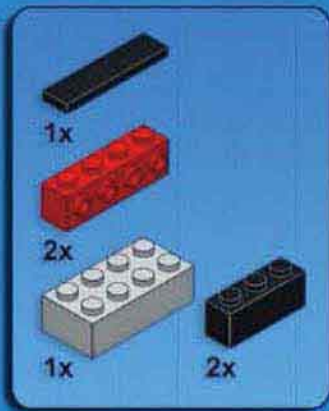

9

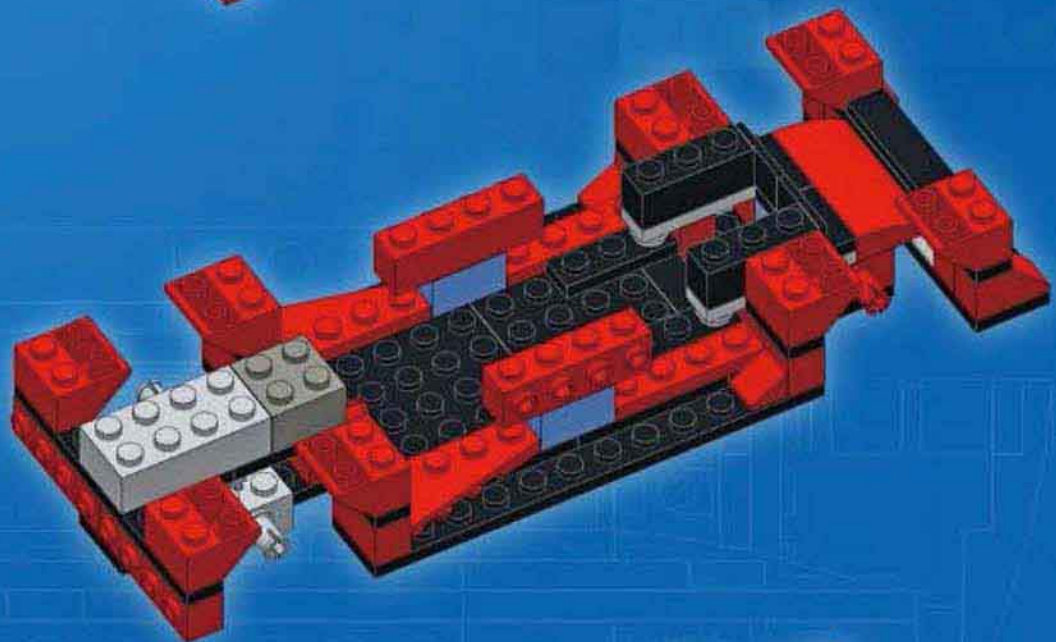
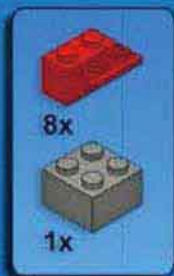

10

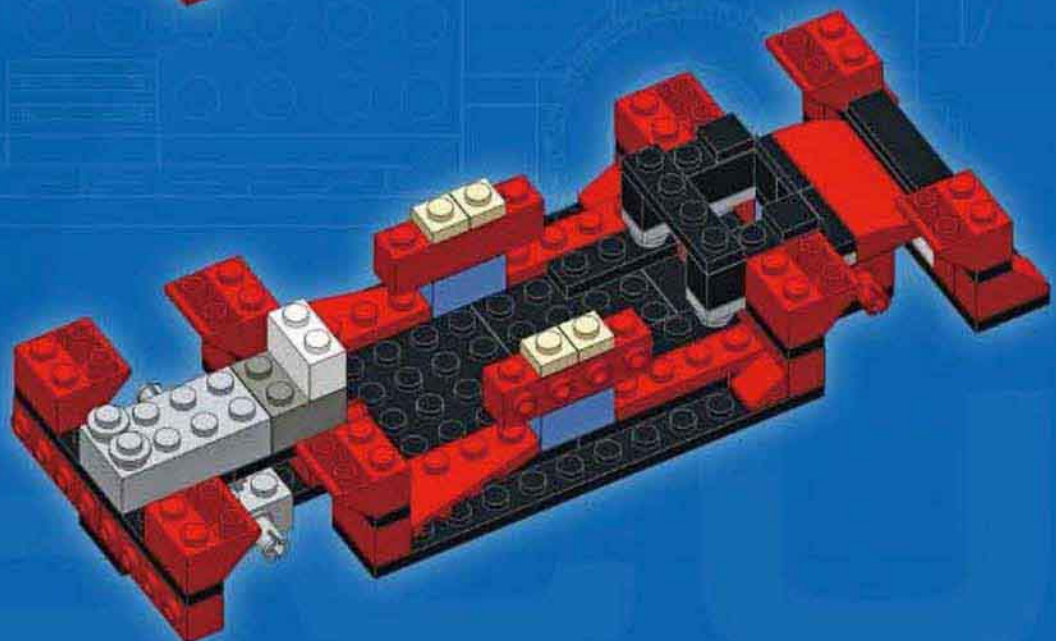



11

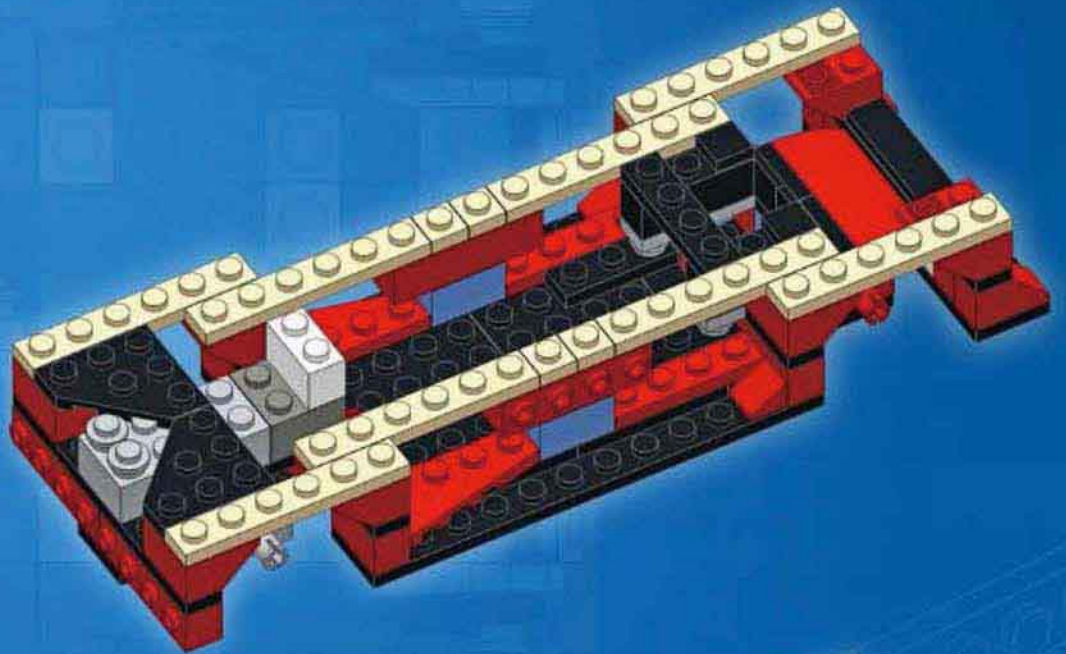
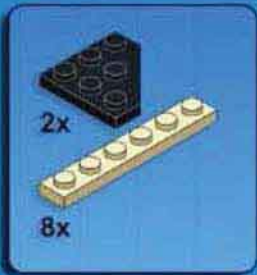

12

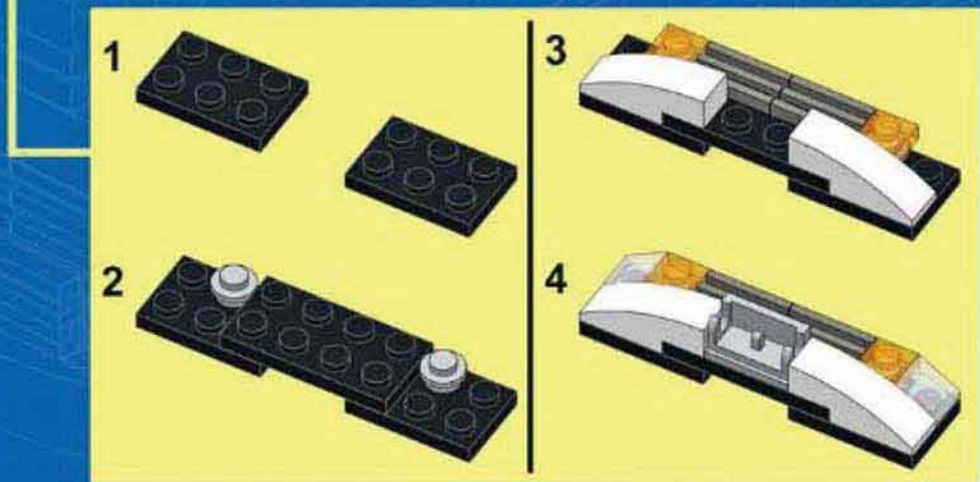
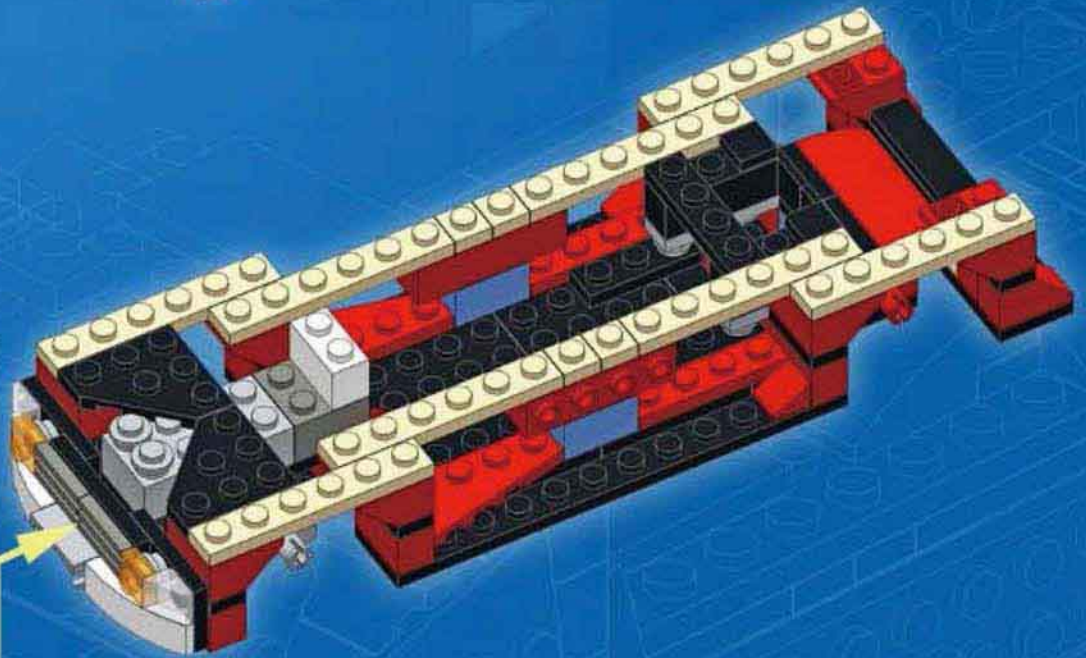



13

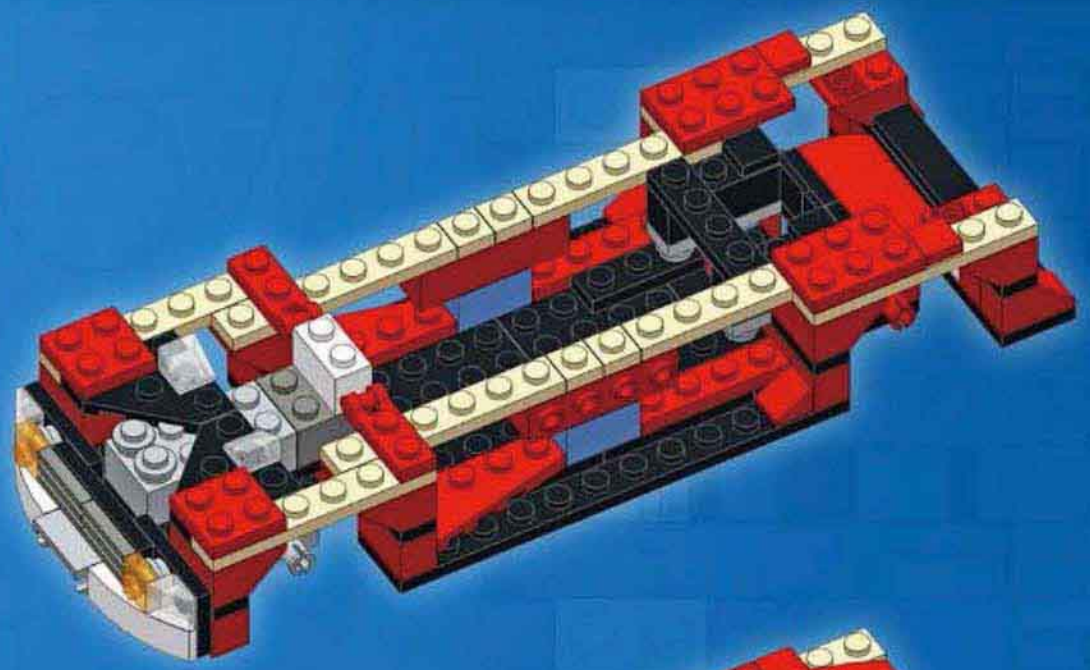
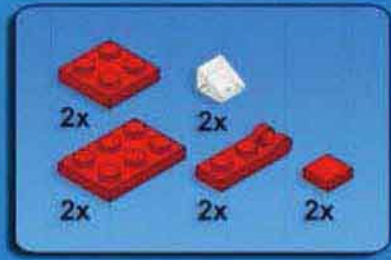

14

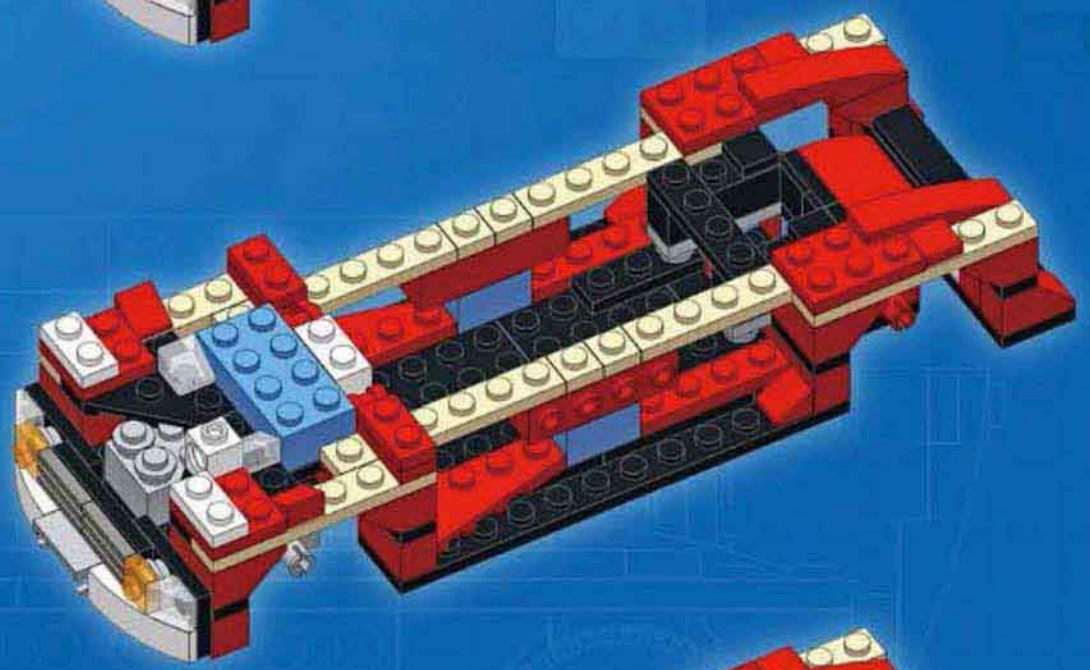
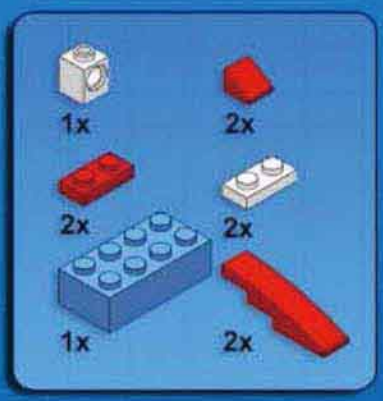

15

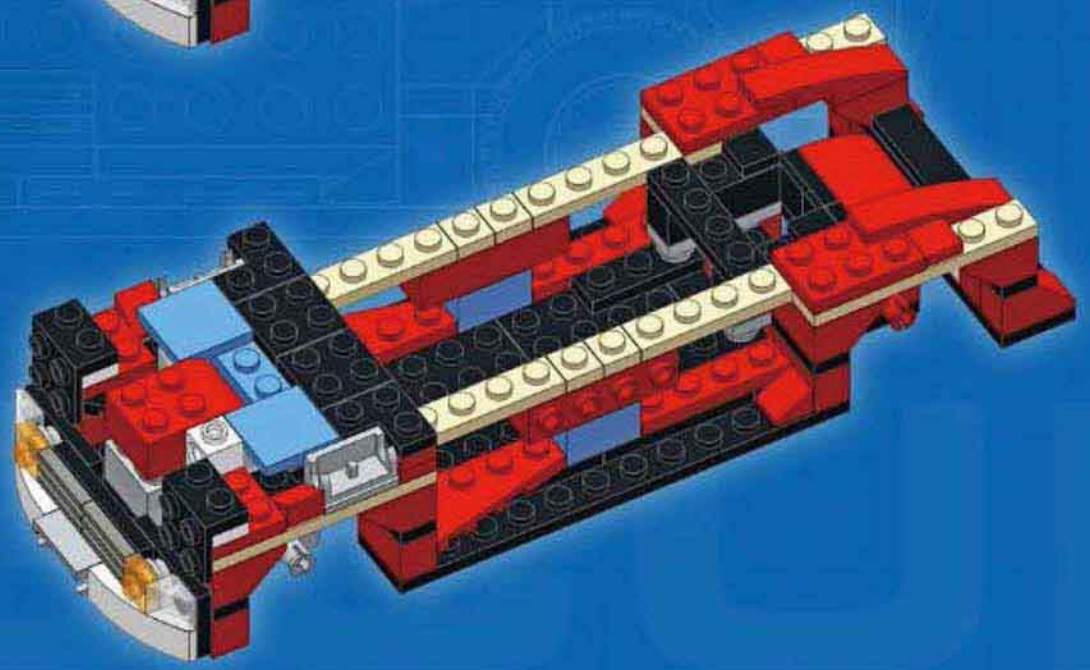
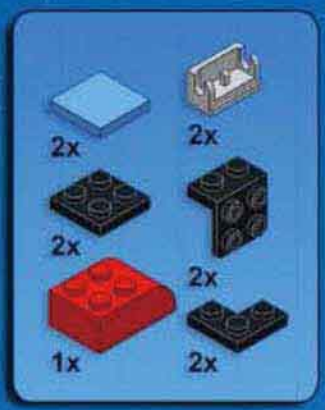







17

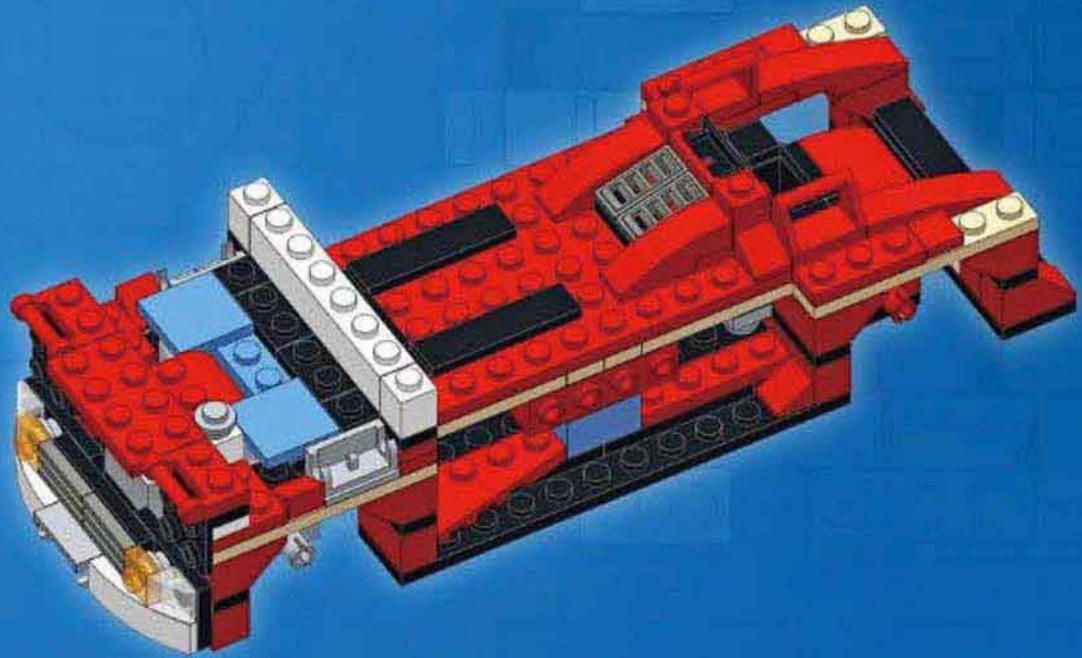
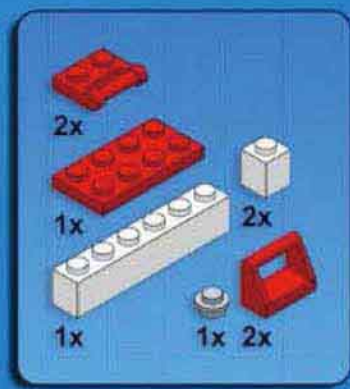

18

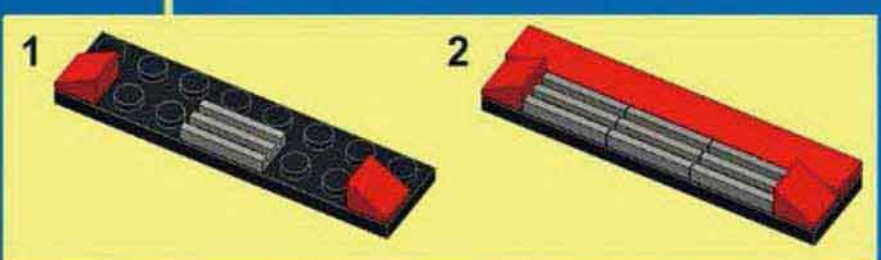
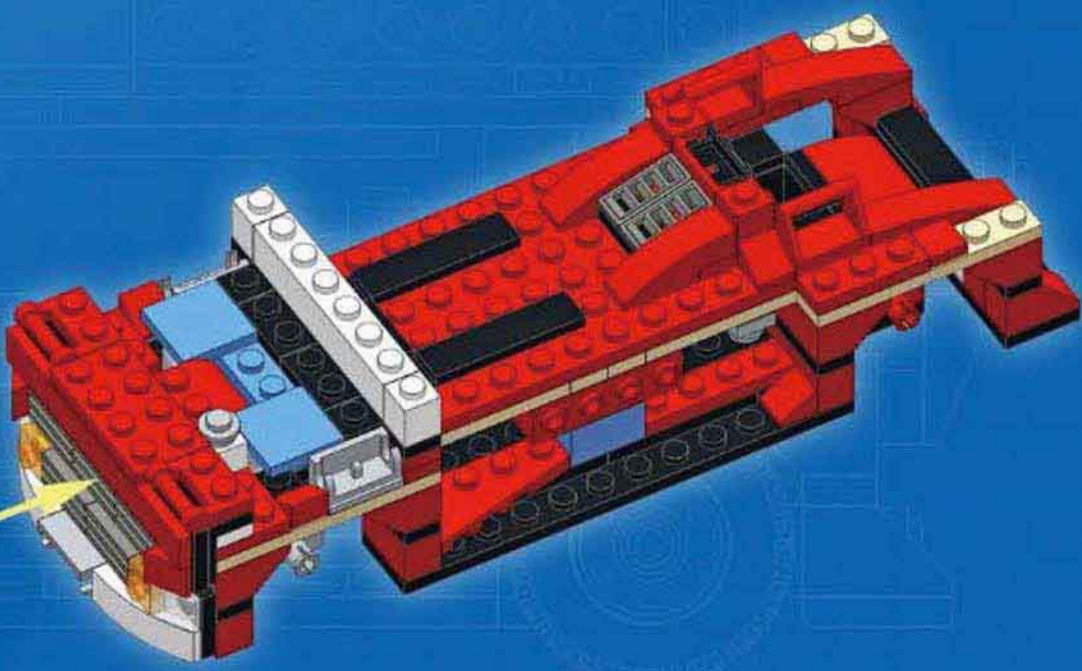
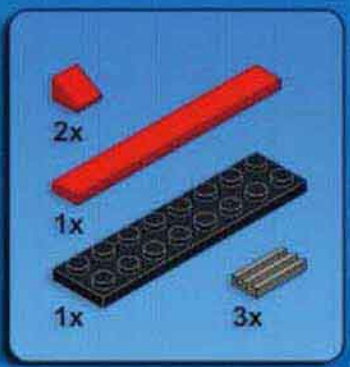



19

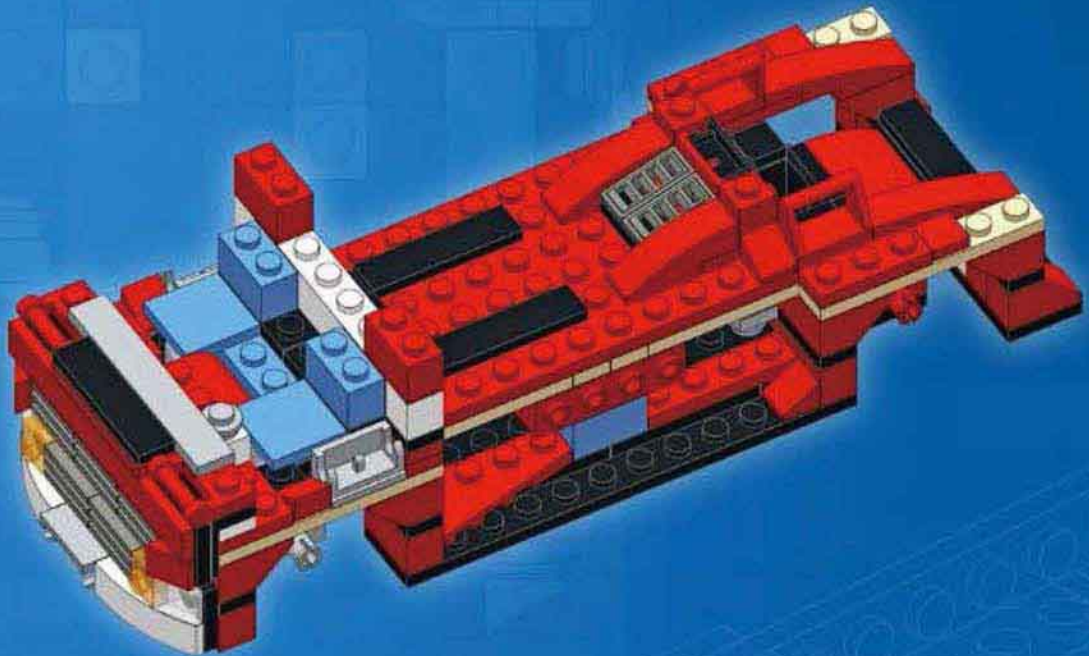
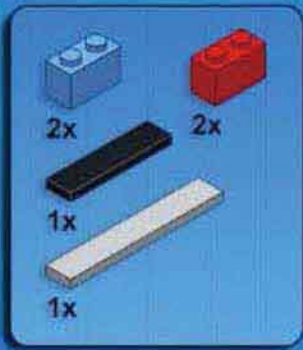

20

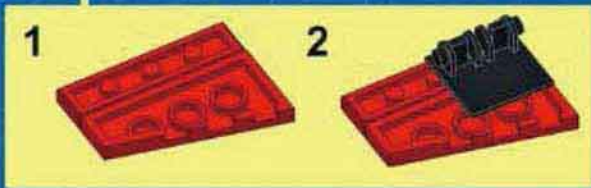
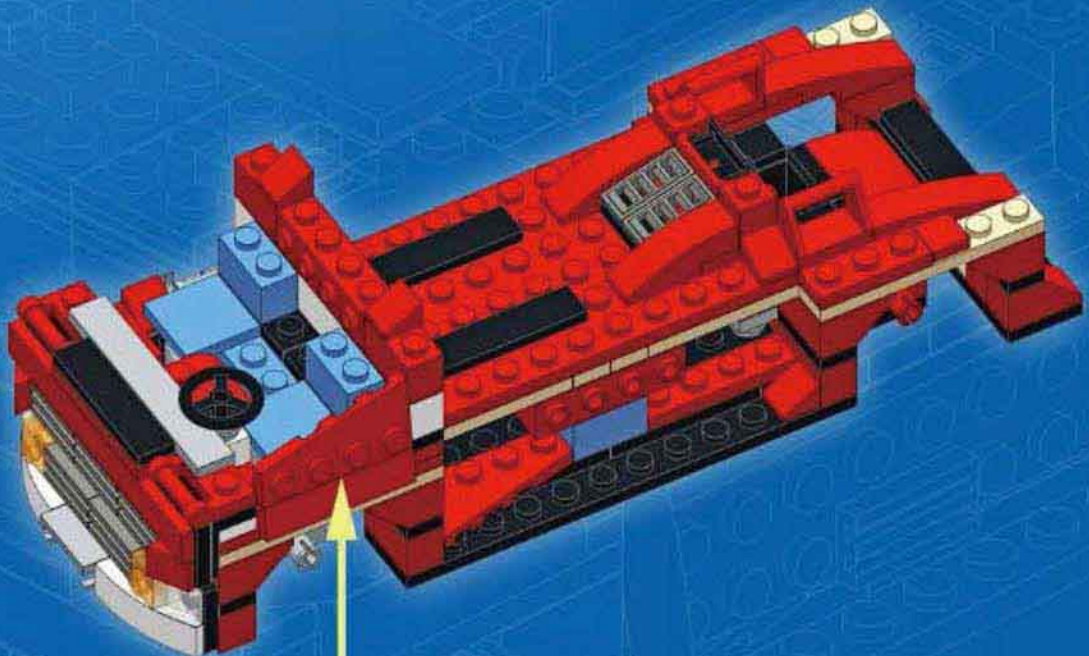
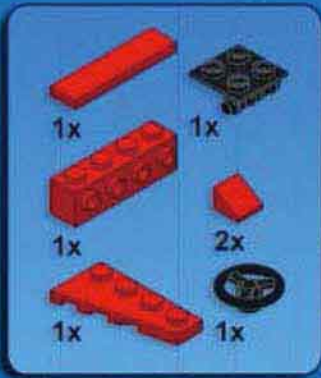

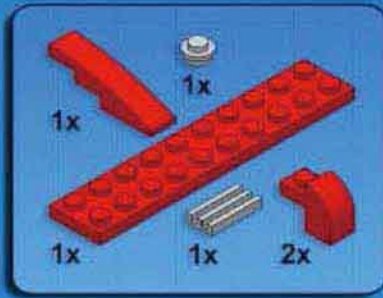

21

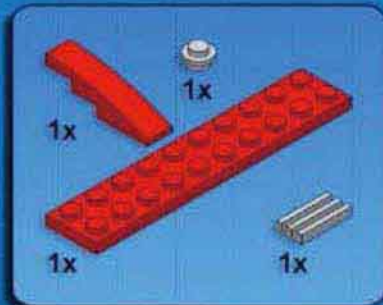
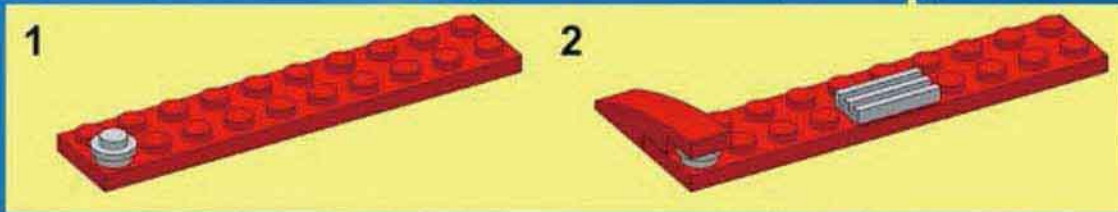
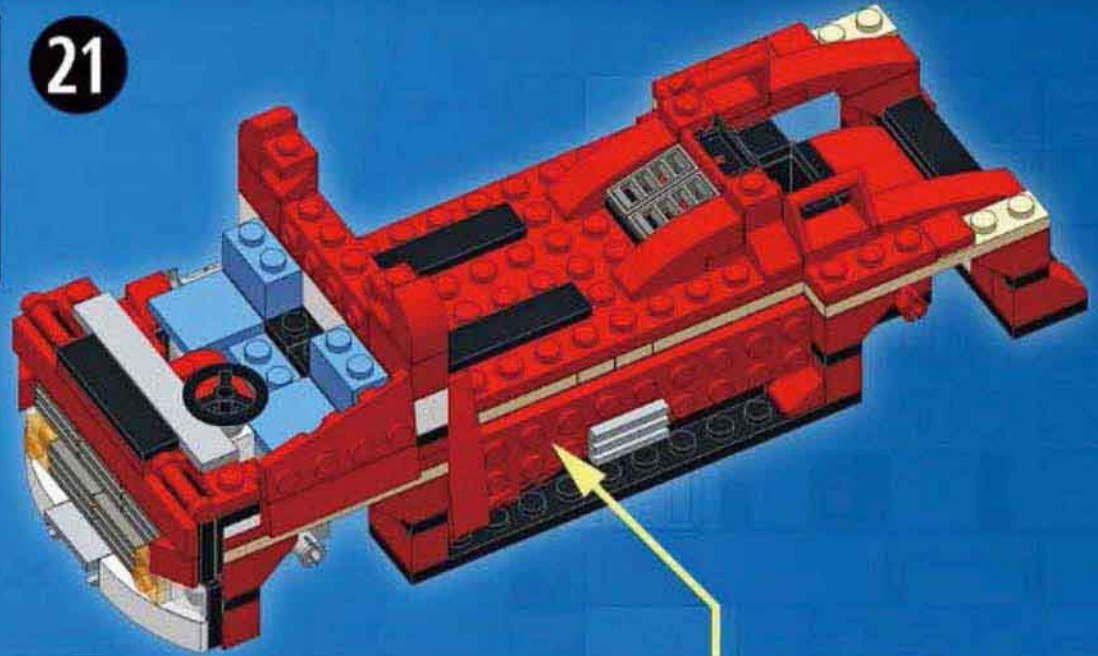

22

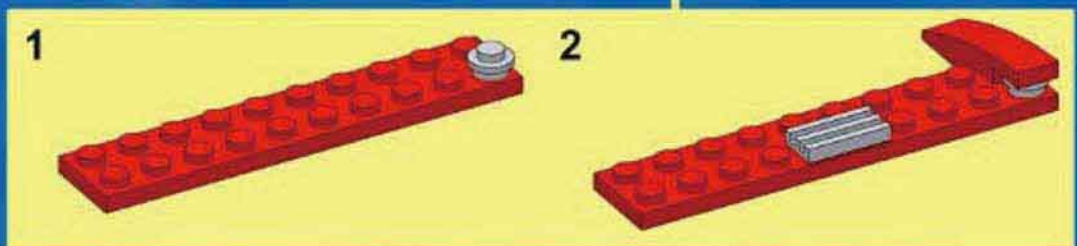
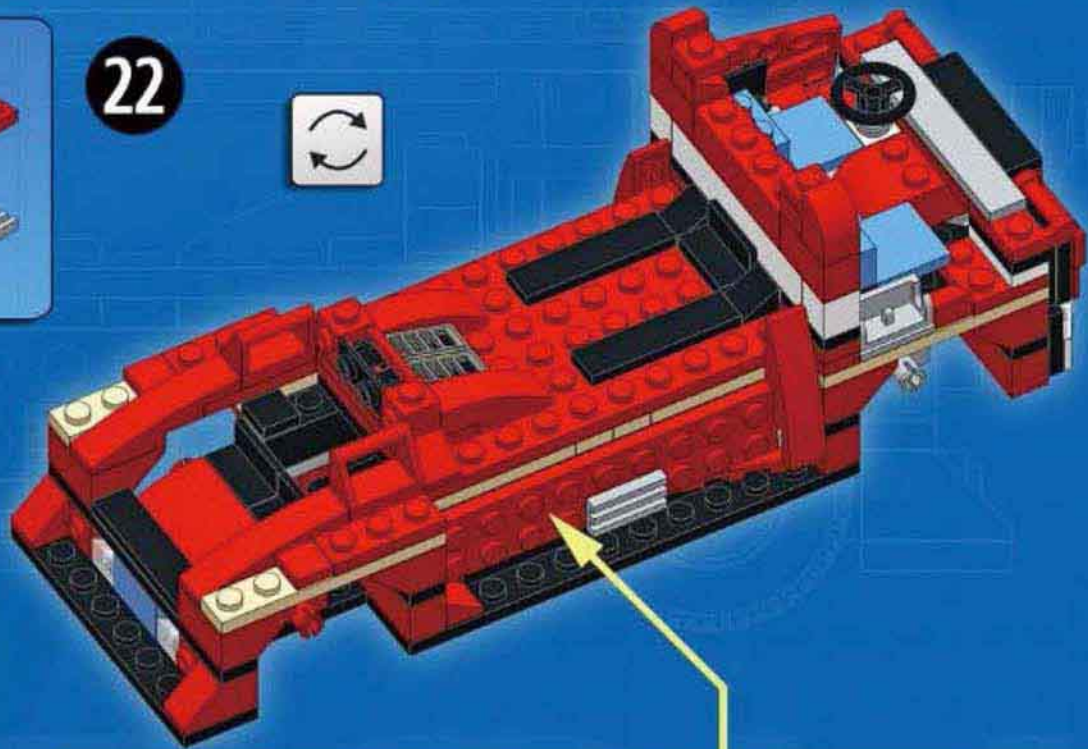



23

- 1x
- 1x
- 1x
- 2x

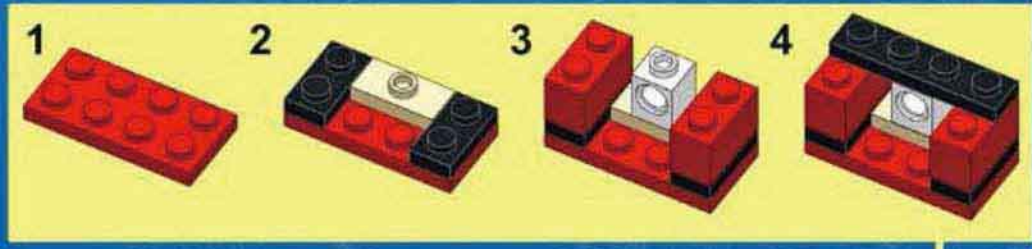

24

- 2x
- 1x
- 1x
- 1x
- 1x
- 2x

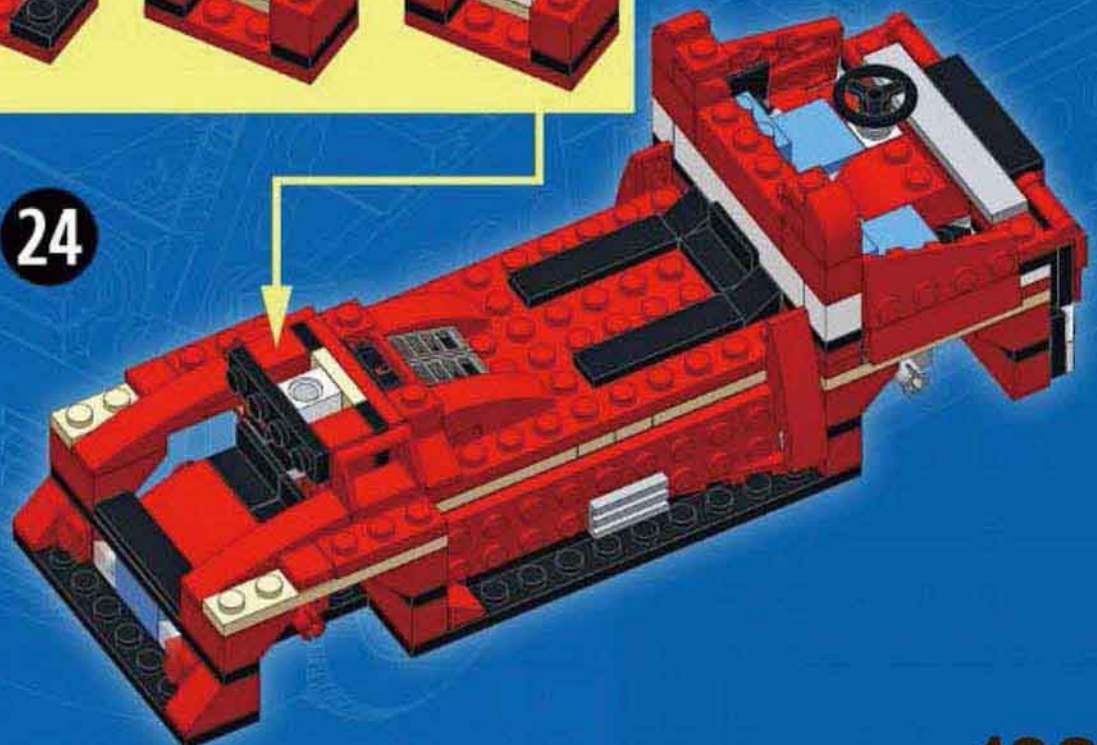

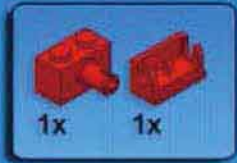

25

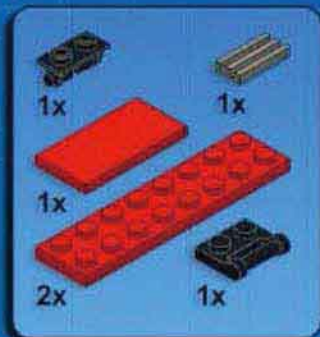
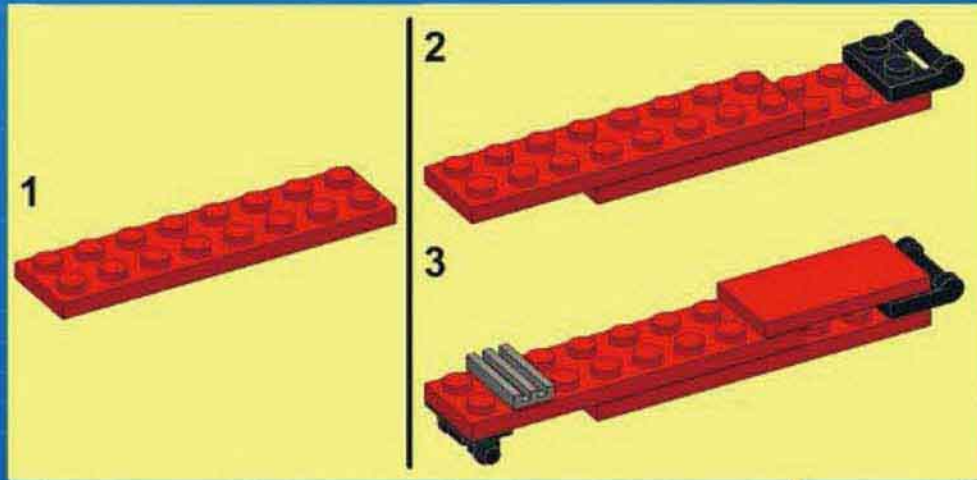
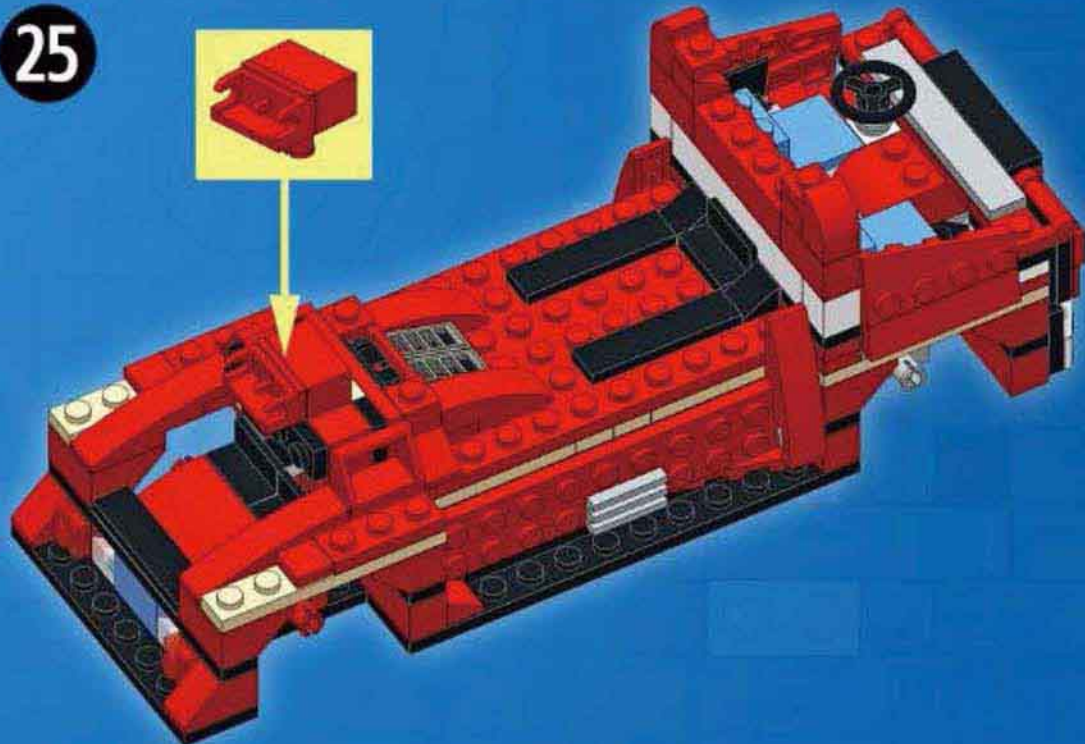

26

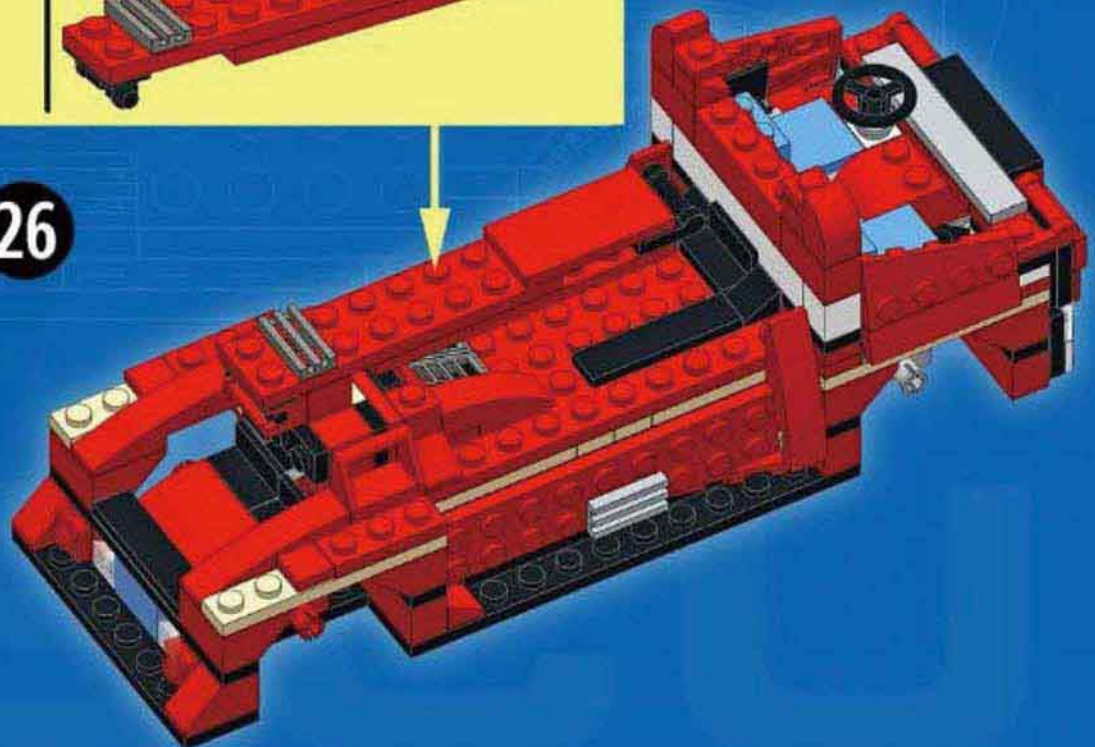



27

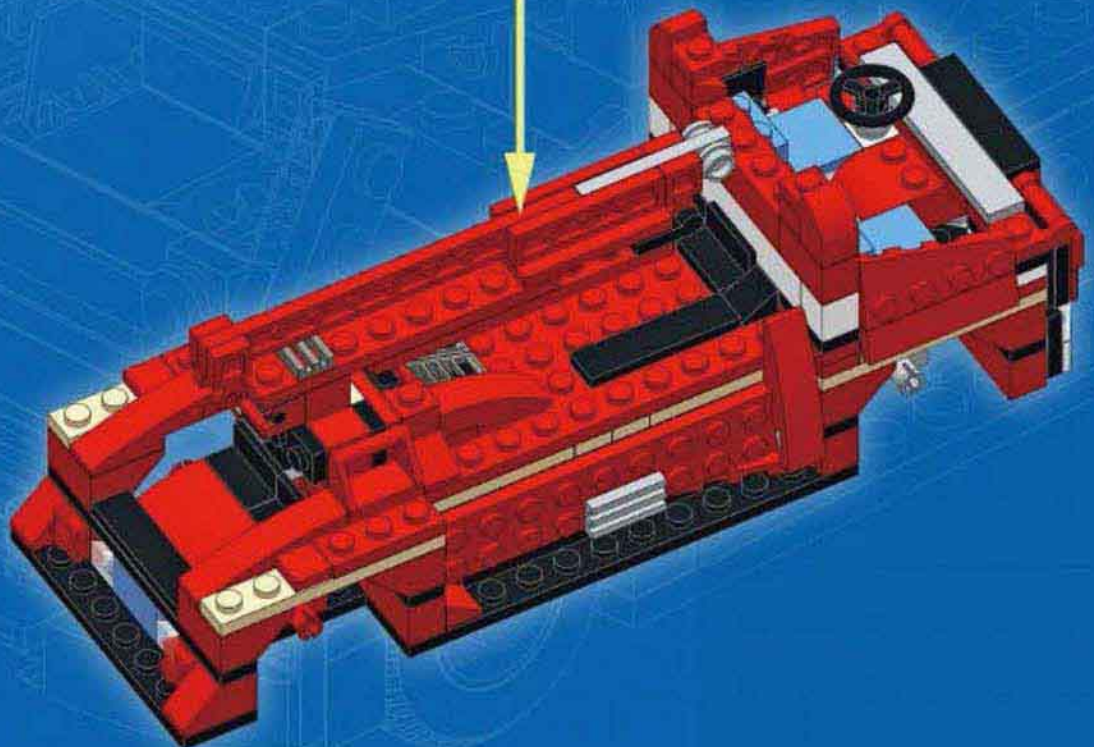
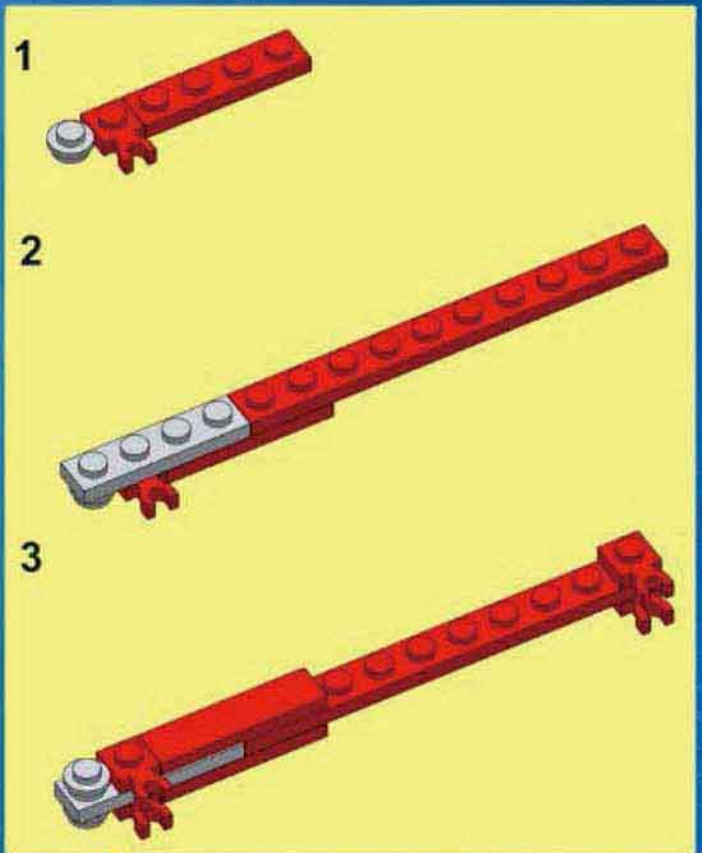
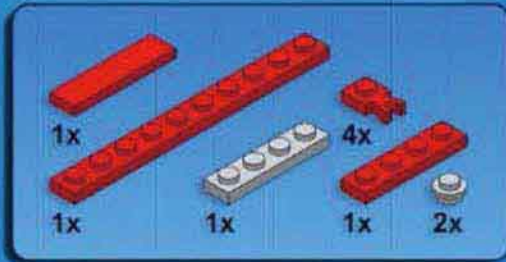



28

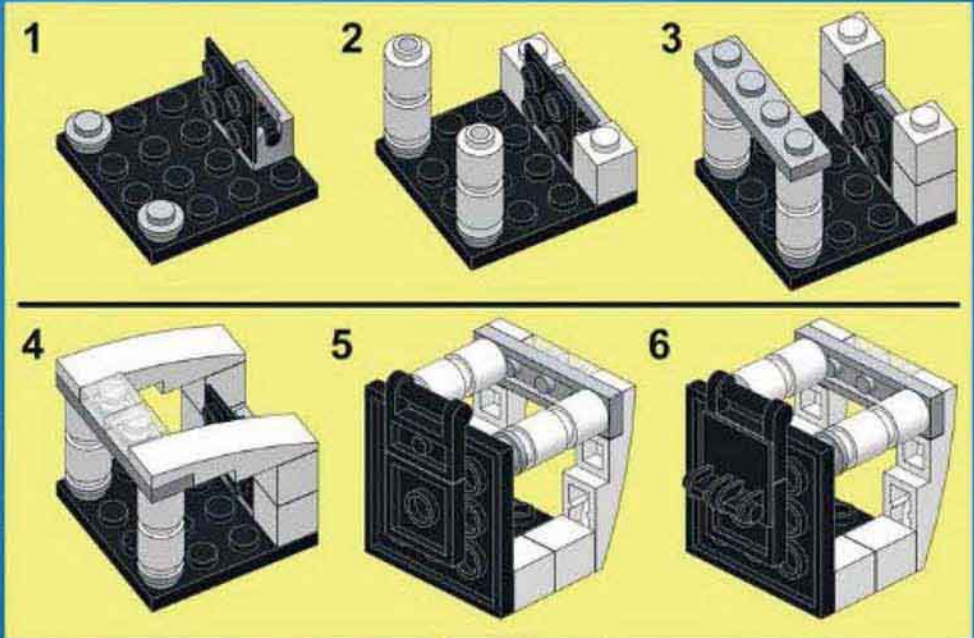
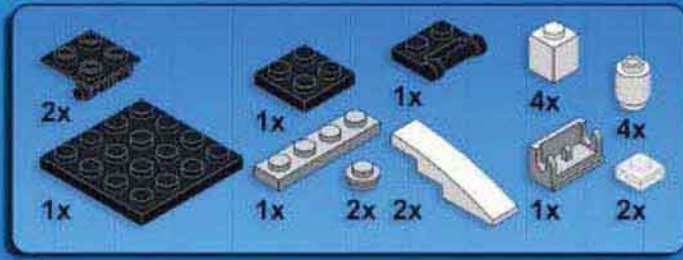





29

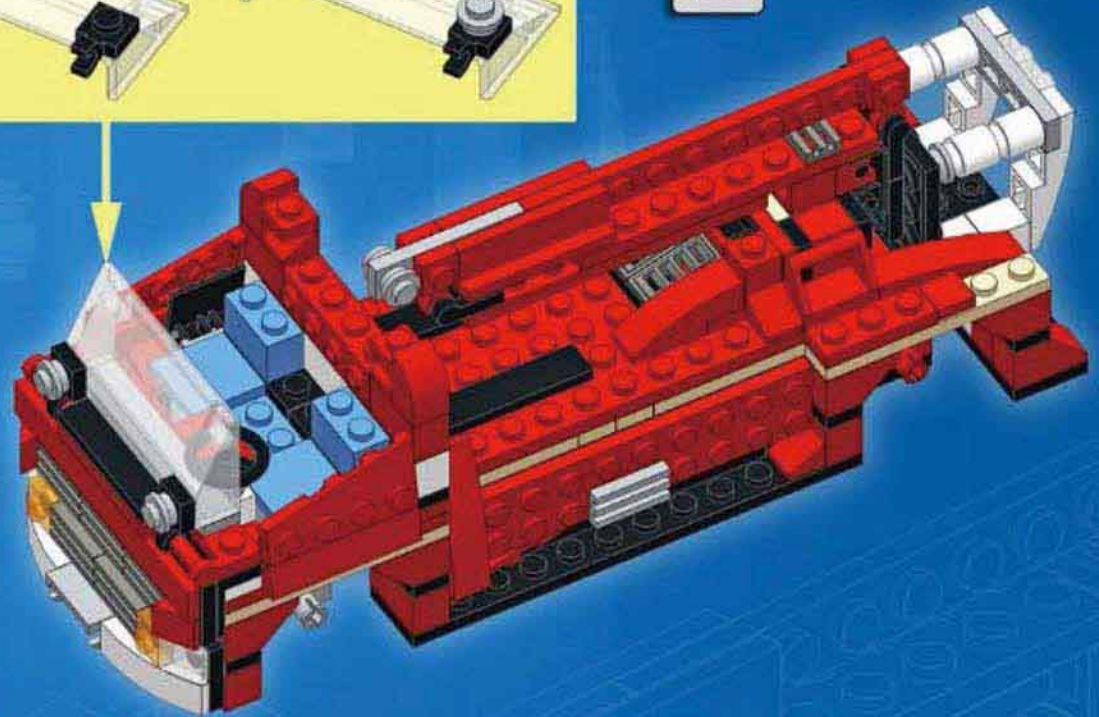
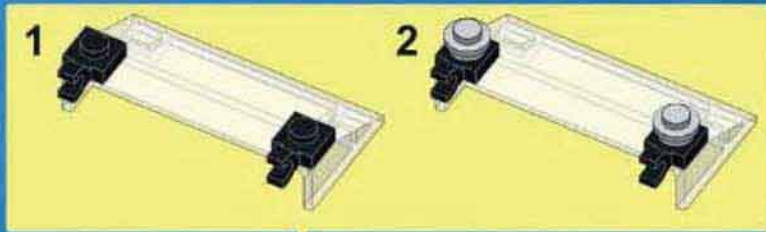

30

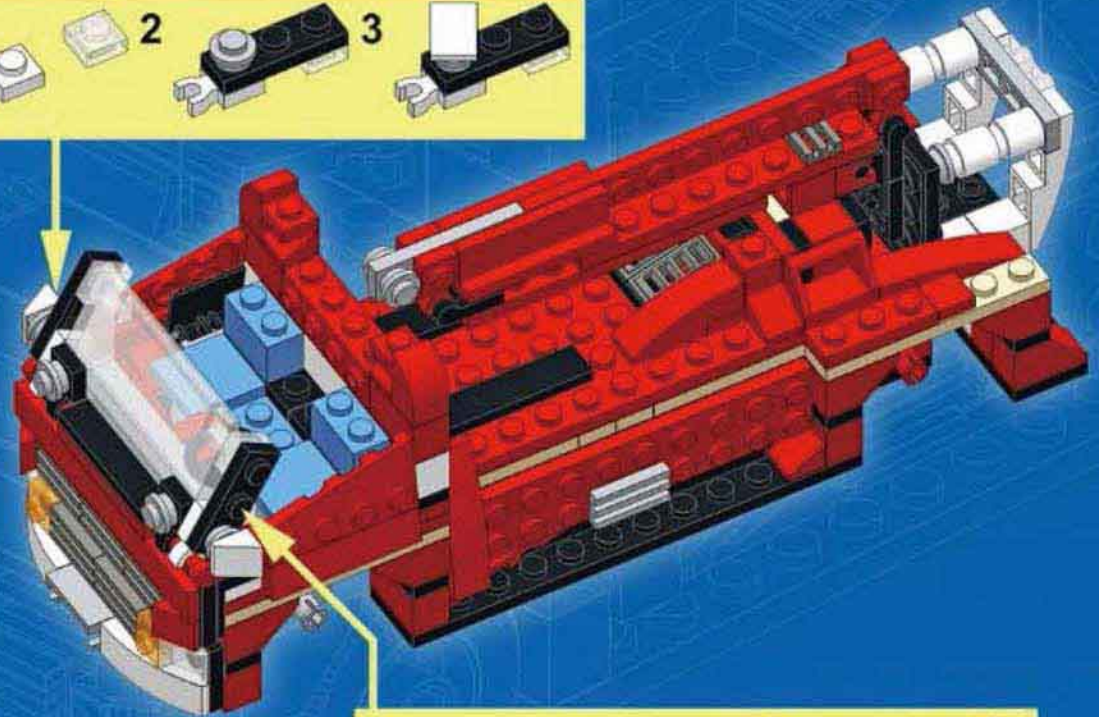
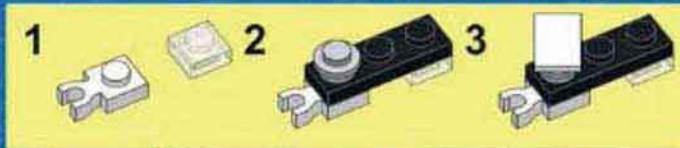



31

- 2x
- 2x
- 1x
- 1x
- 1x
- 2x
- 1x
- 1x
- 1x
- 2x

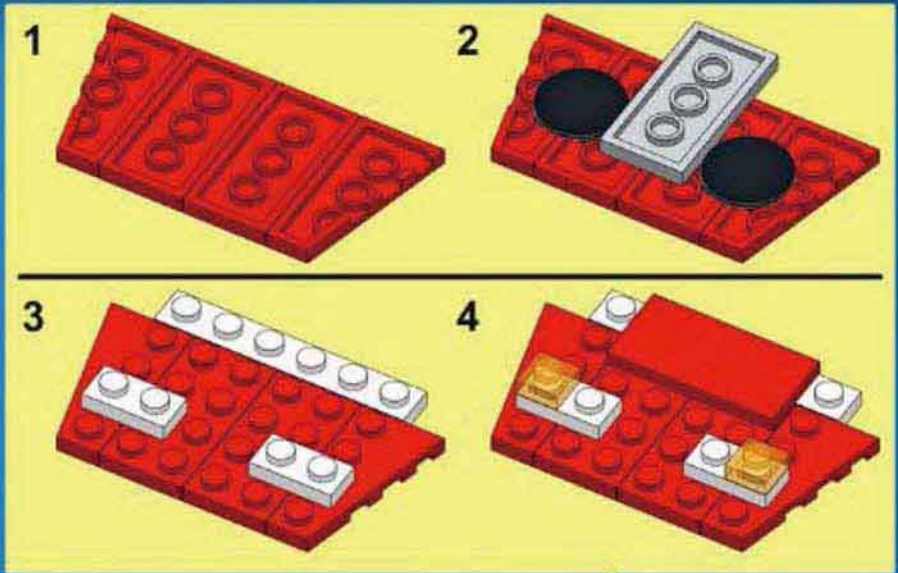

32

- 4x
- 4x



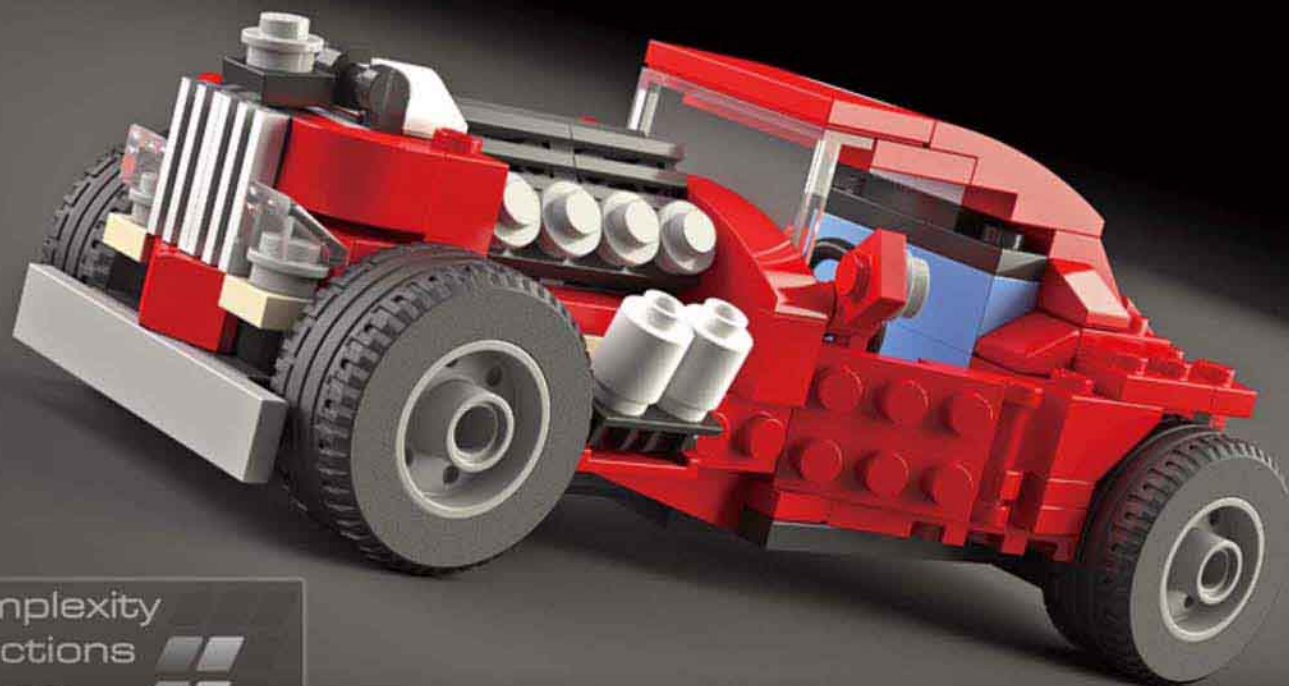

Complexity  
Functions  
Pieces

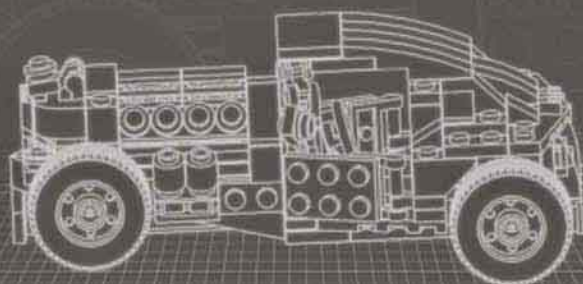
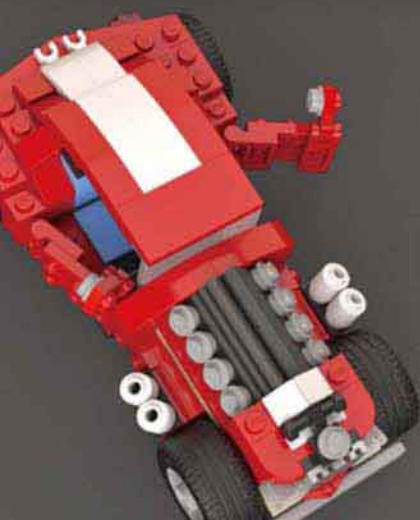

## HOT ROD

Design notes: chop top, exposed V8 engine, big exhaust pipes, wide rear axle

### Technical specifications:

Dimensions (l × w × h): 18 × 10 × 8 studs  
Wheelbase: 13 studs  
Axle width front/rear: 8/10 studs

Features: opening doors

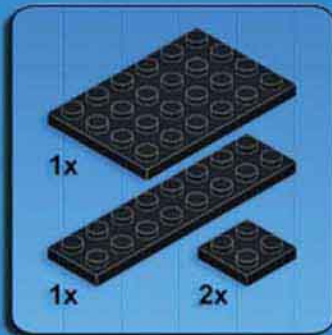

1

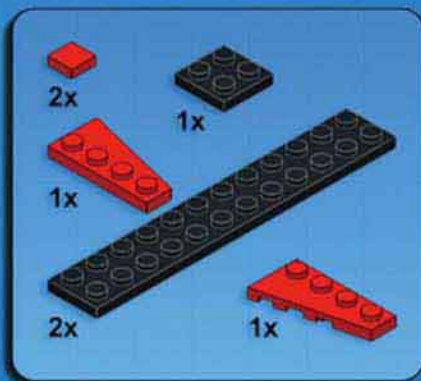

2

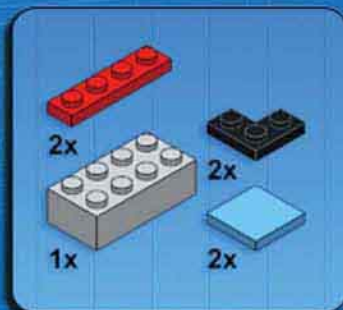

3

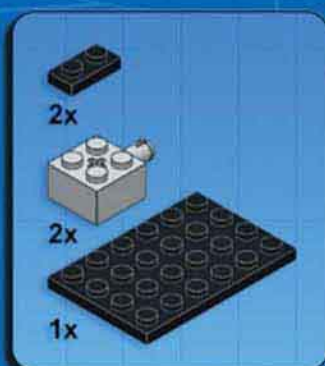
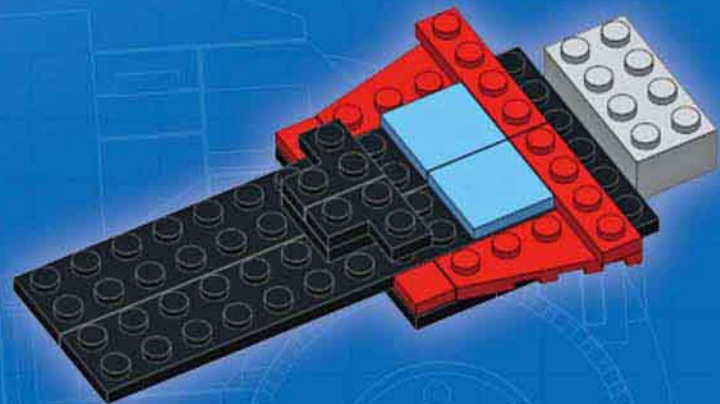

4

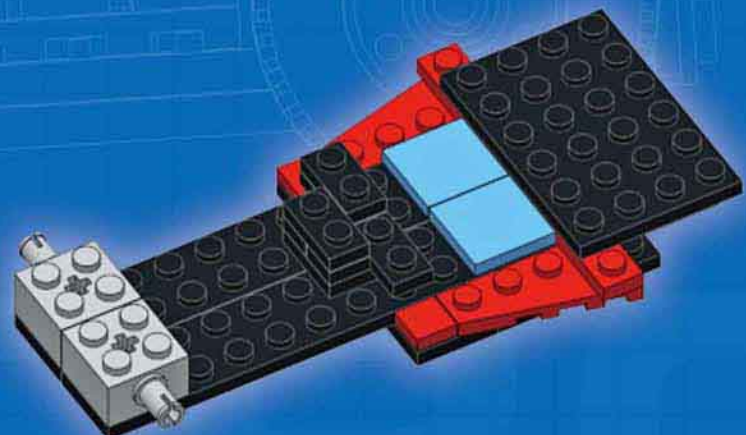



5

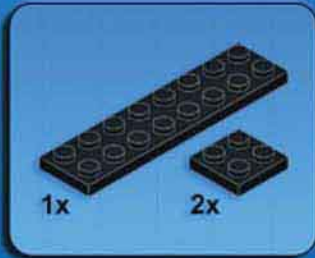
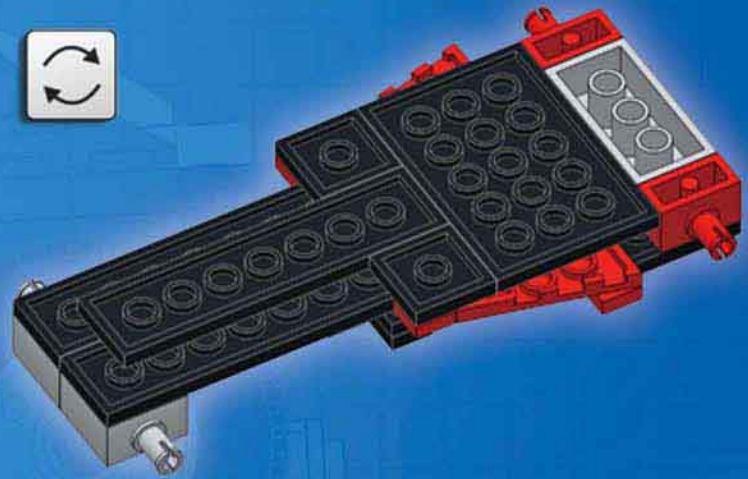

6

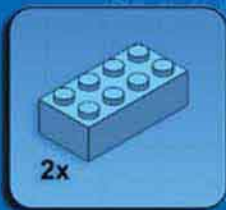
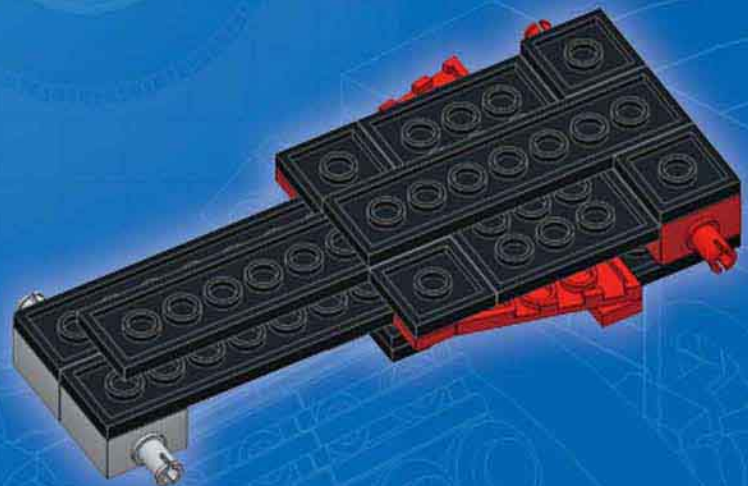

7

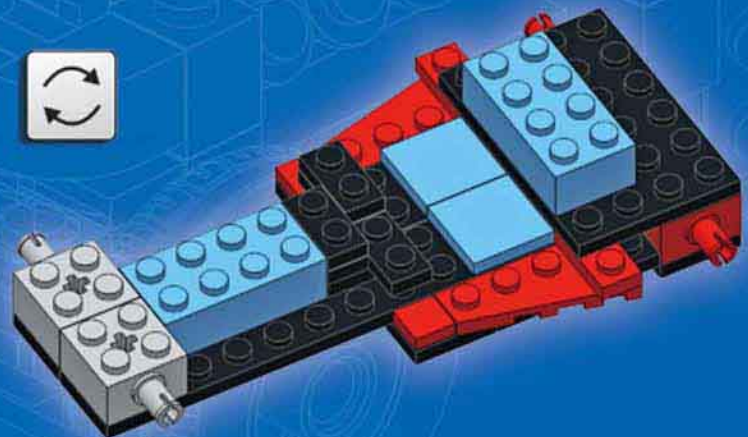



8

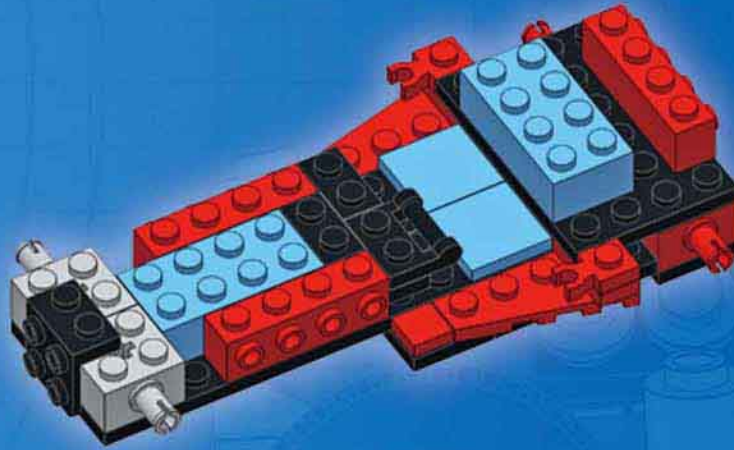
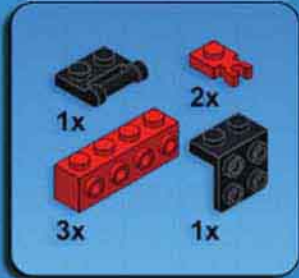

9

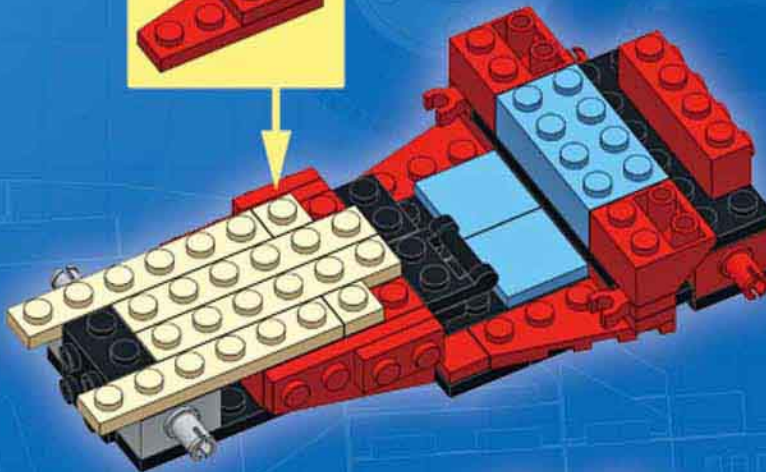
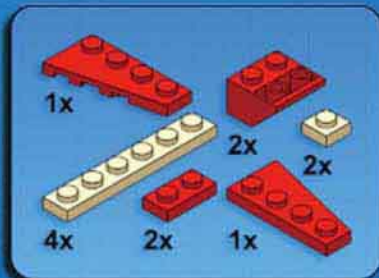

10

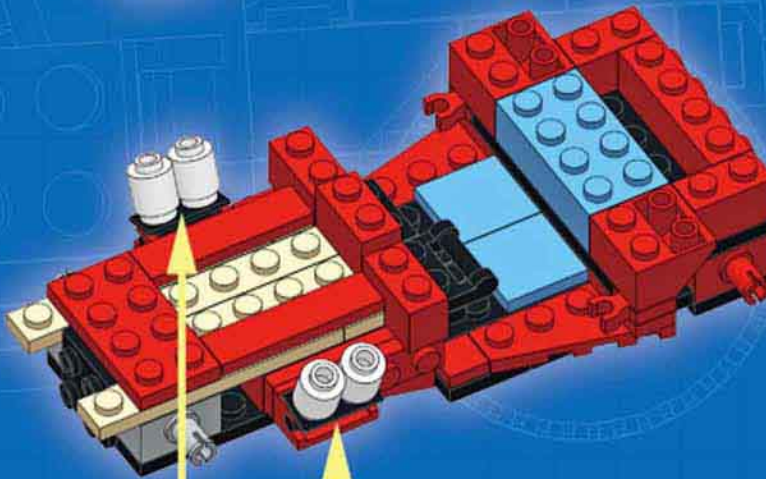
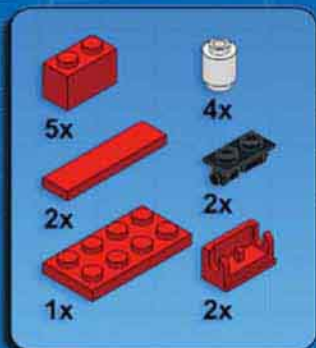

11

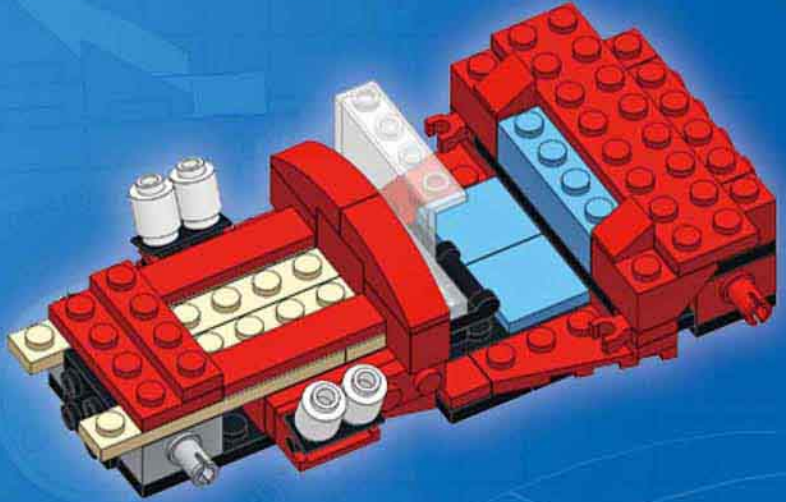
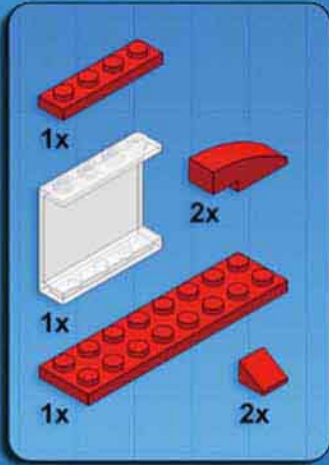

12

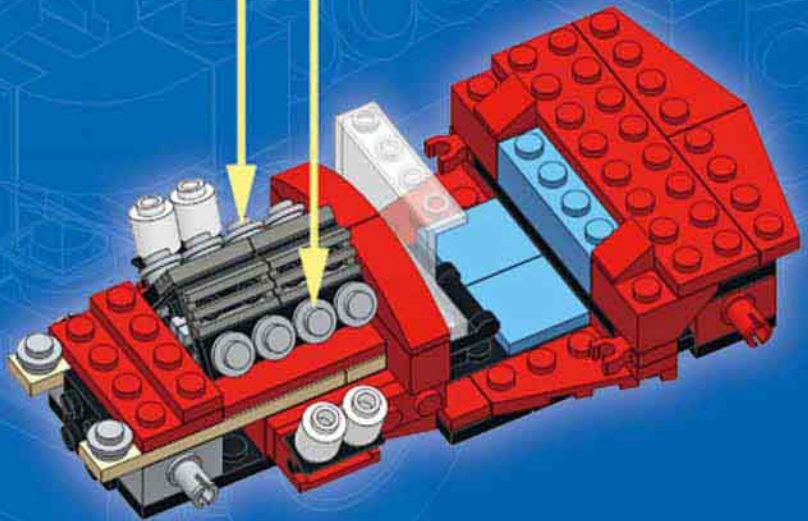
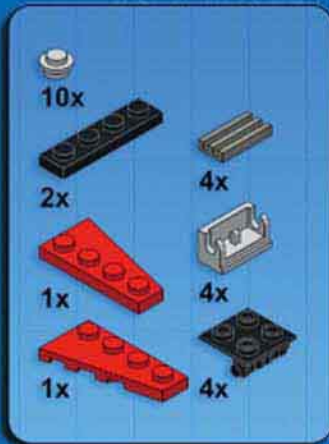



13

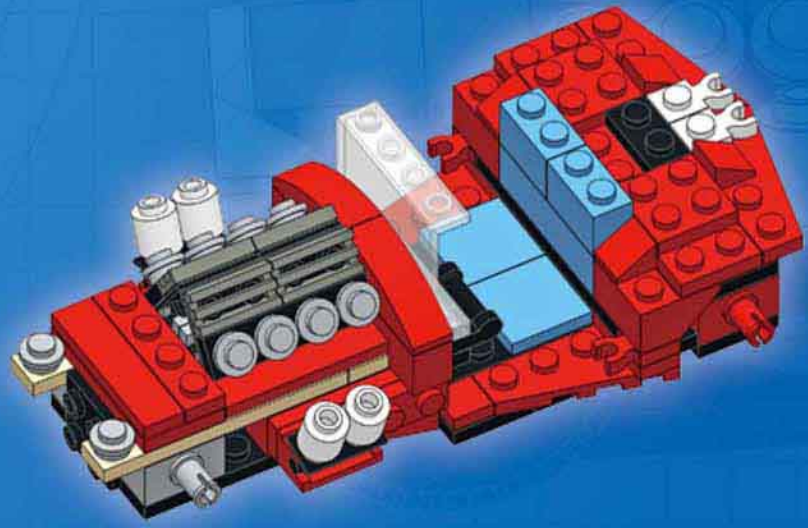
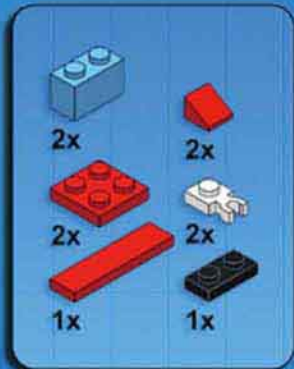

14

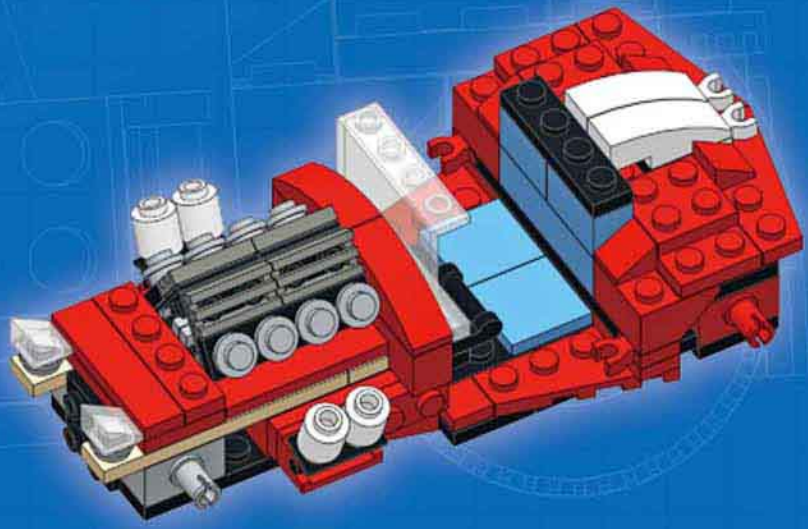



15

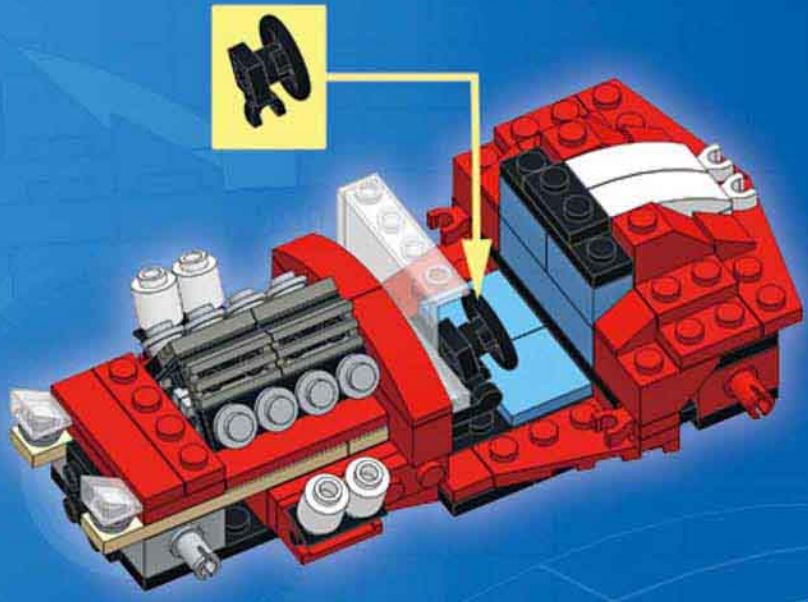
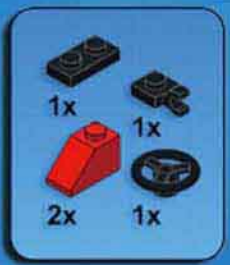

16

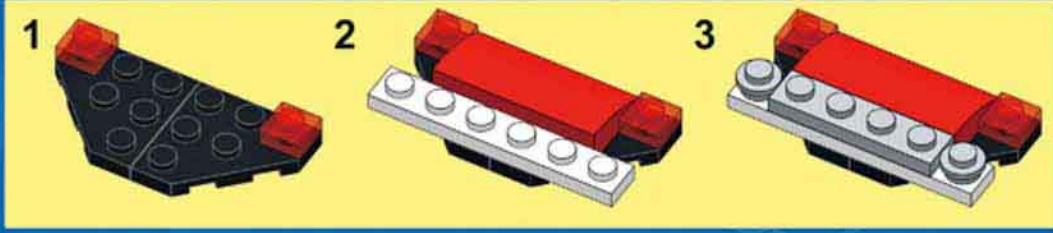
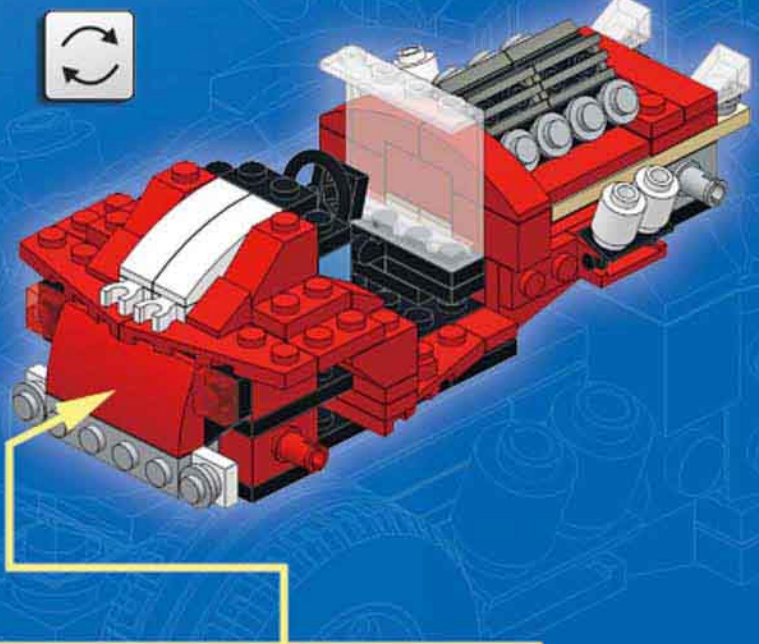
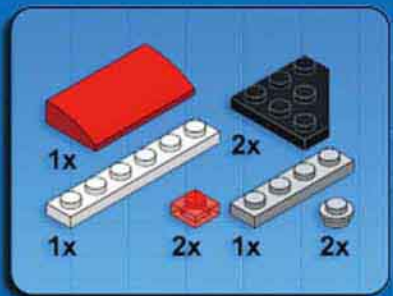



17

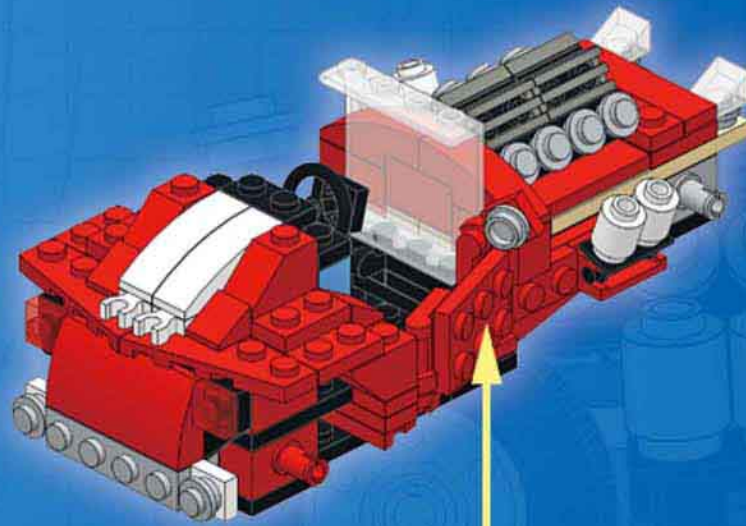
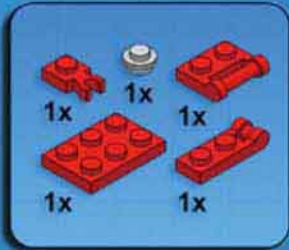

18

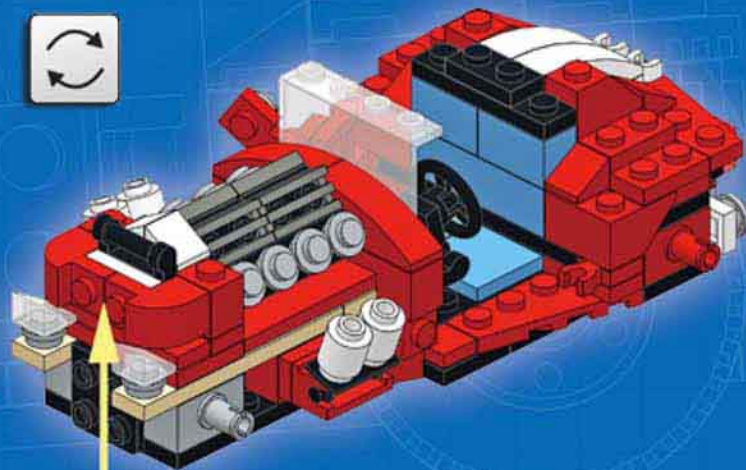
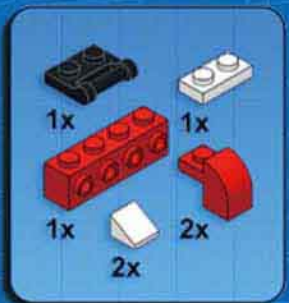



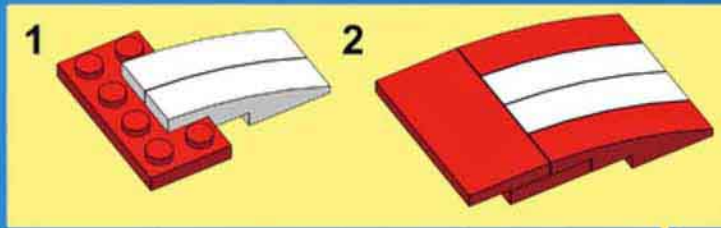

21

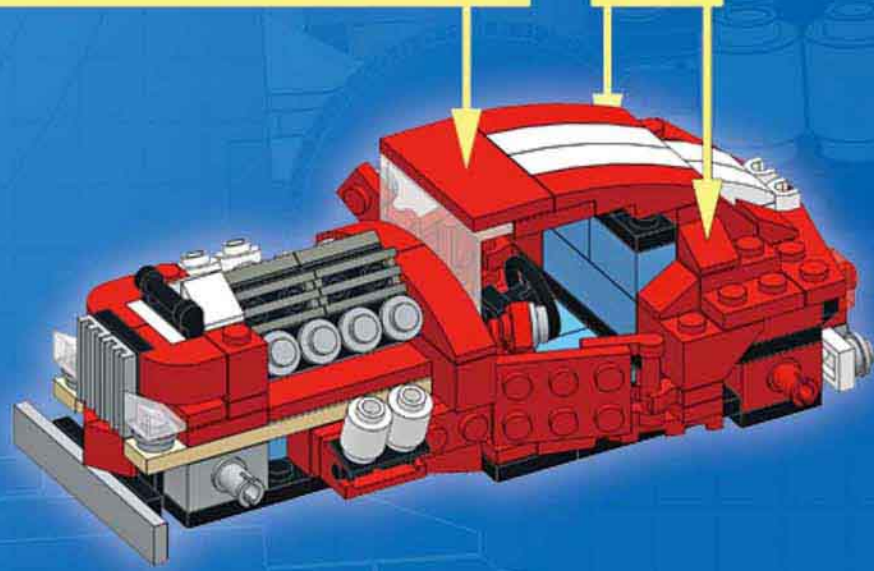
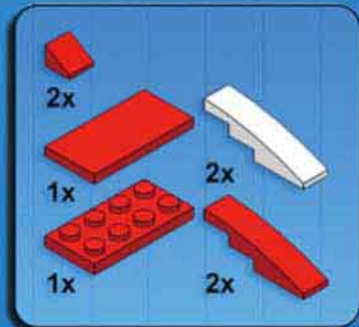

22

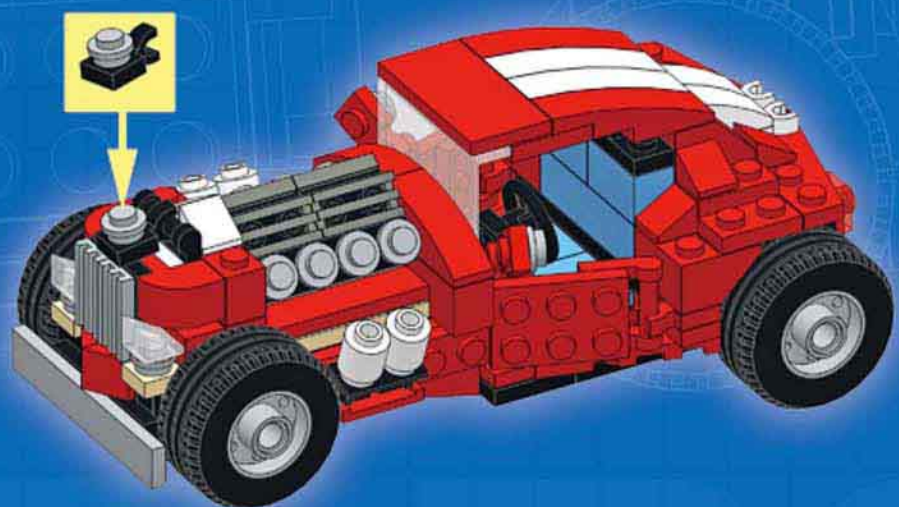



Complexity   
Functions   
Pieces 

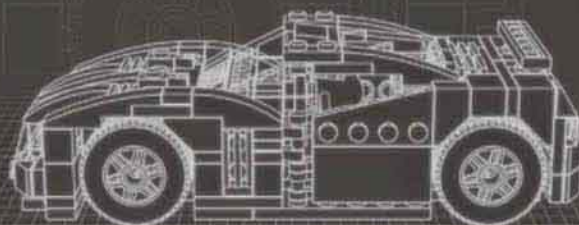
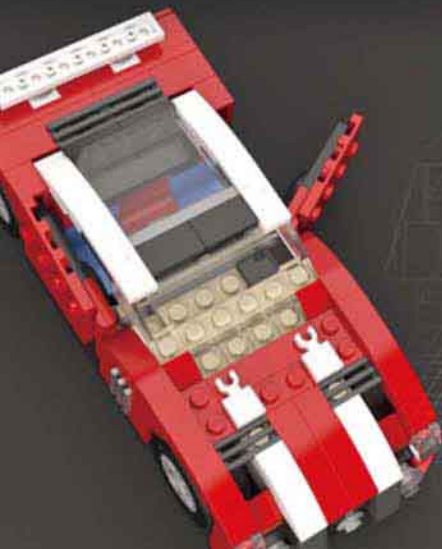
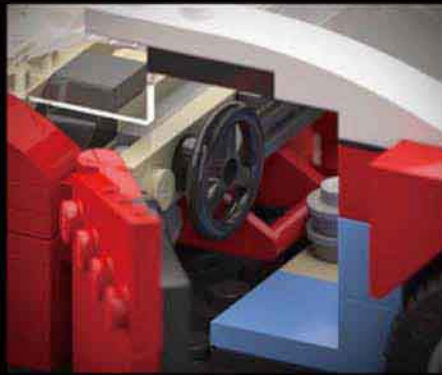

## GRAN TURISMO

Design notes: low chassis, aerodynamic shape, sophisticated lines, racing stripes, spoiler

### Technical specifications:

Dimensions (l x w x h): 20 x 9 x 7 studs  
Wheelbase: 12 studs  
Axle width front/rear: 8/8 studs

Features: opening doors



1

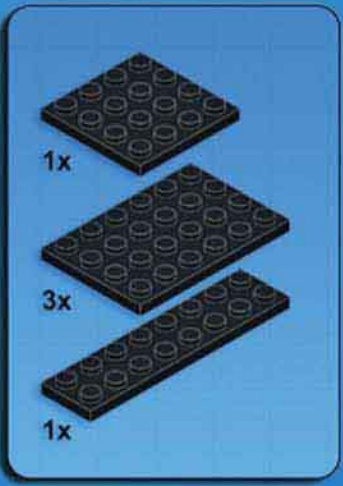

2

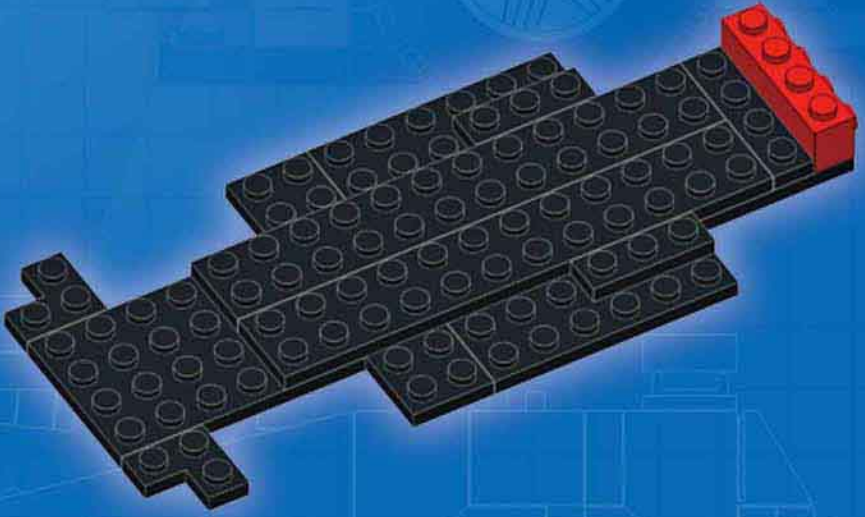
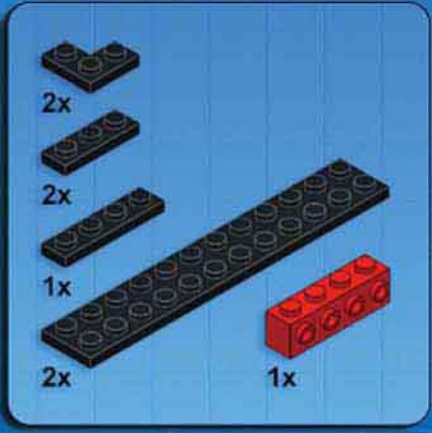

3

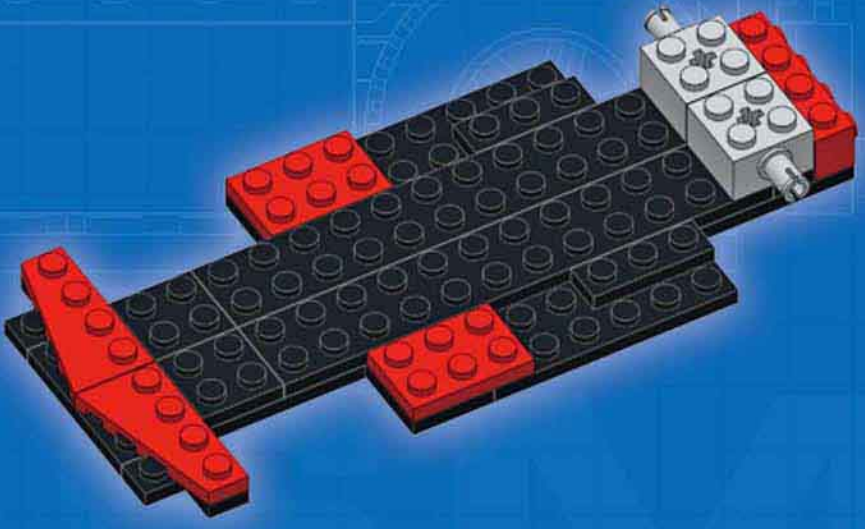
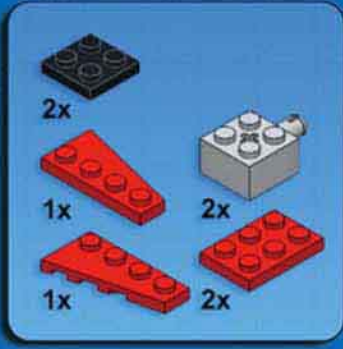



4

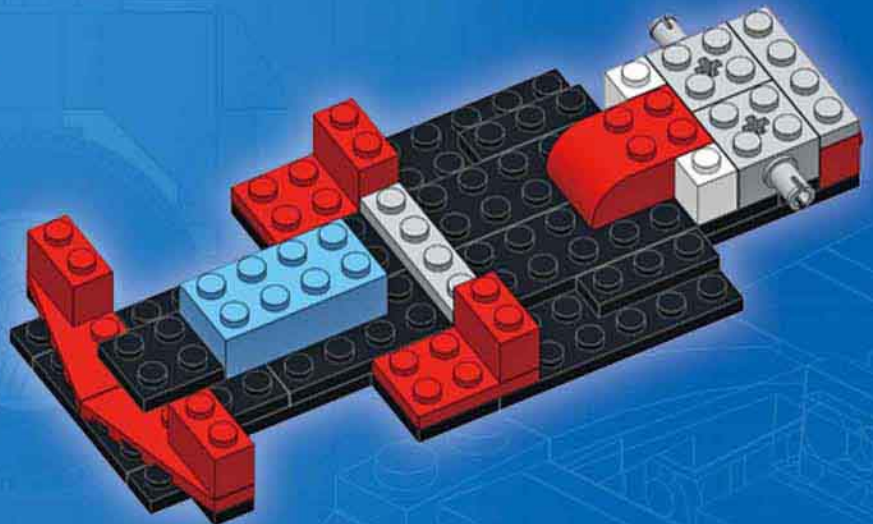
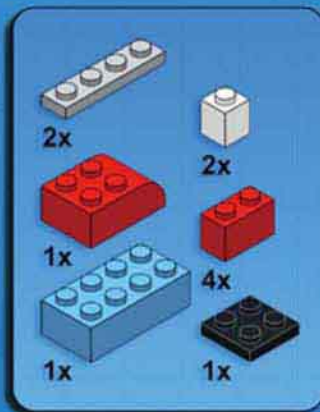

5

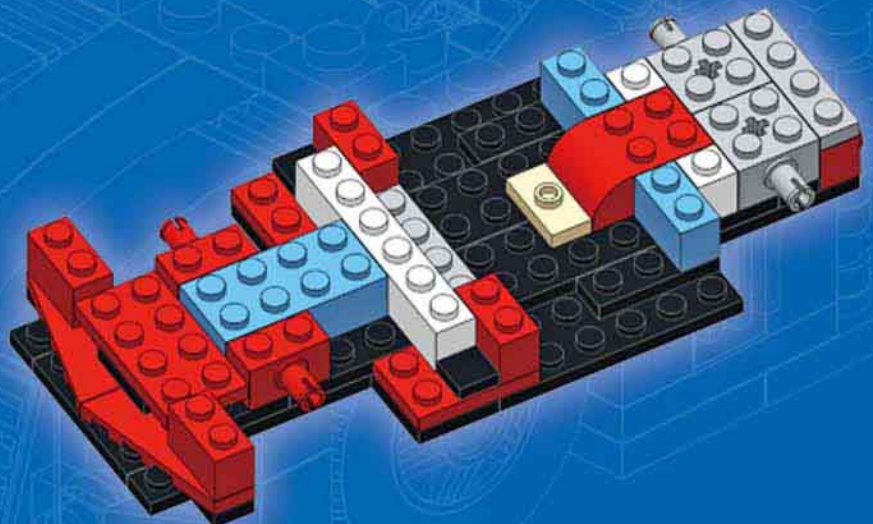
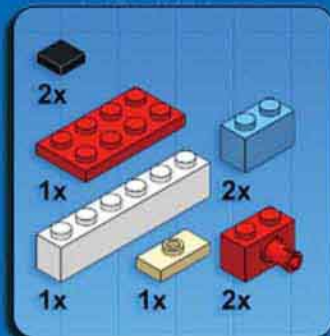



6

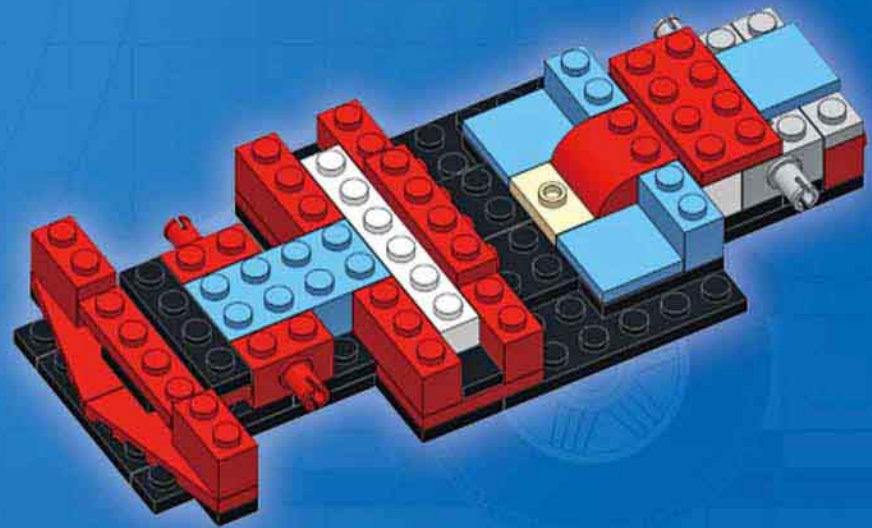
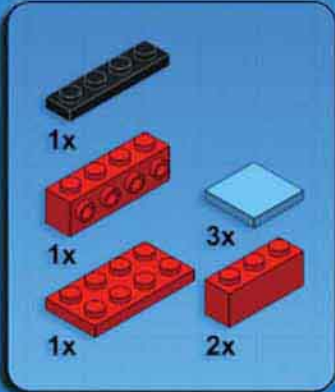

7

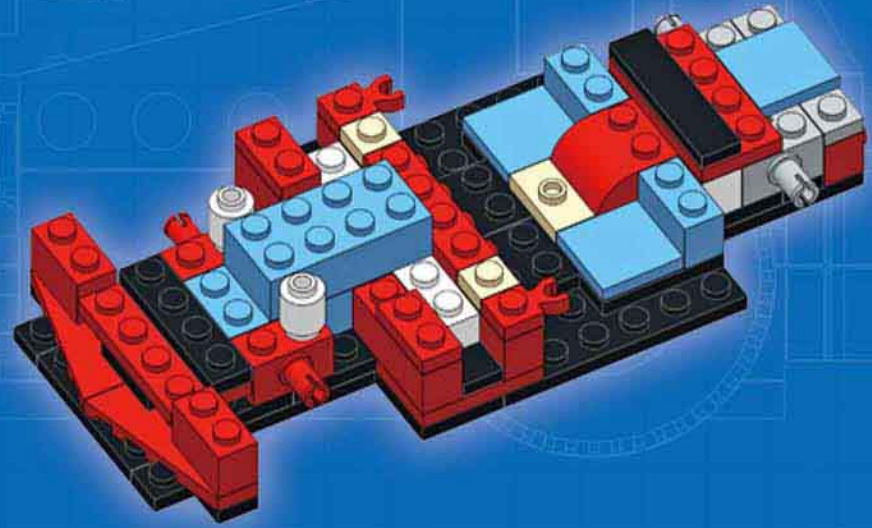
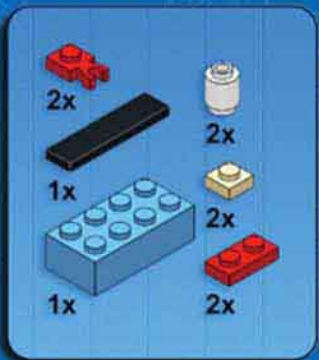





8

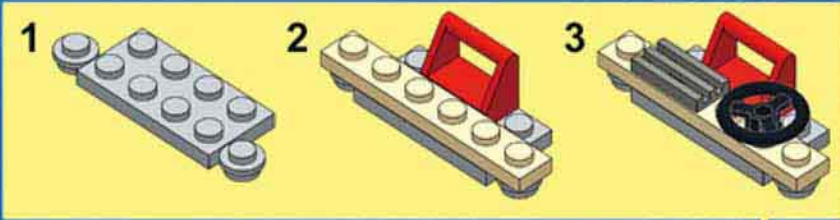
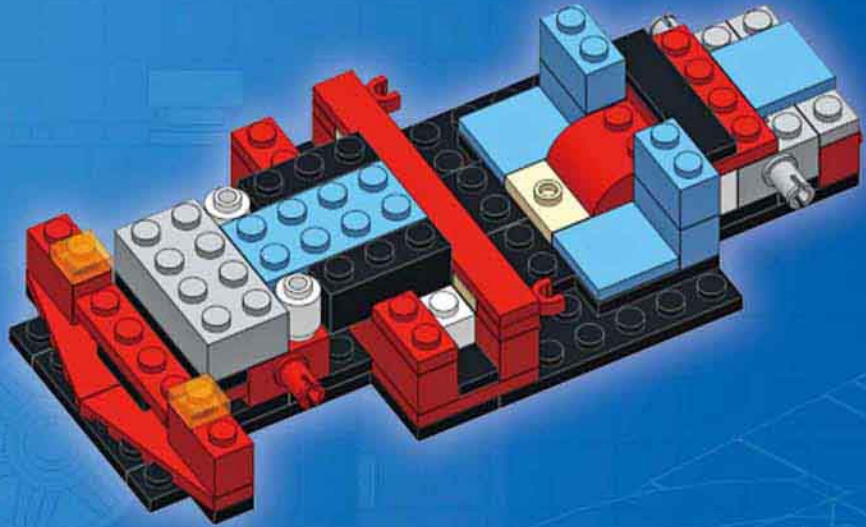
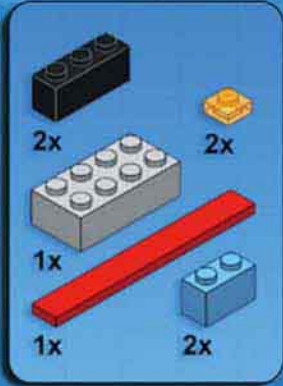

9

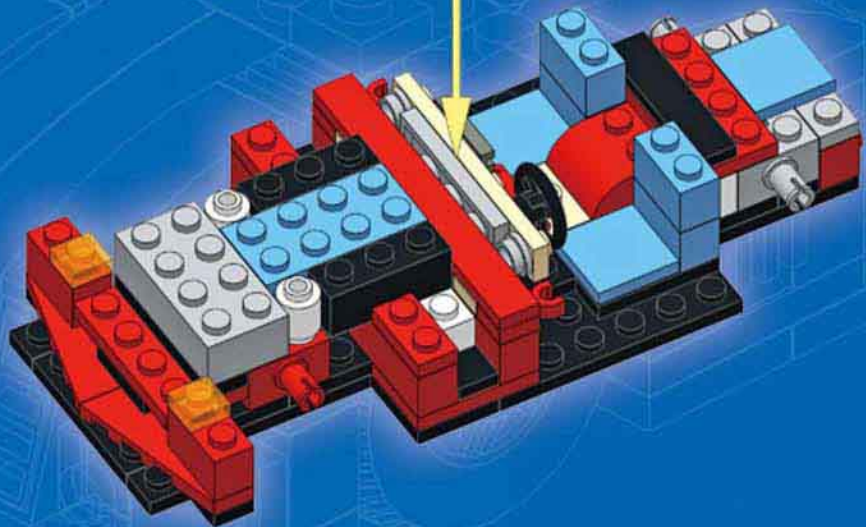



10

- 2x
- 2x
- 1x
- 1x
- 1x
- 2x

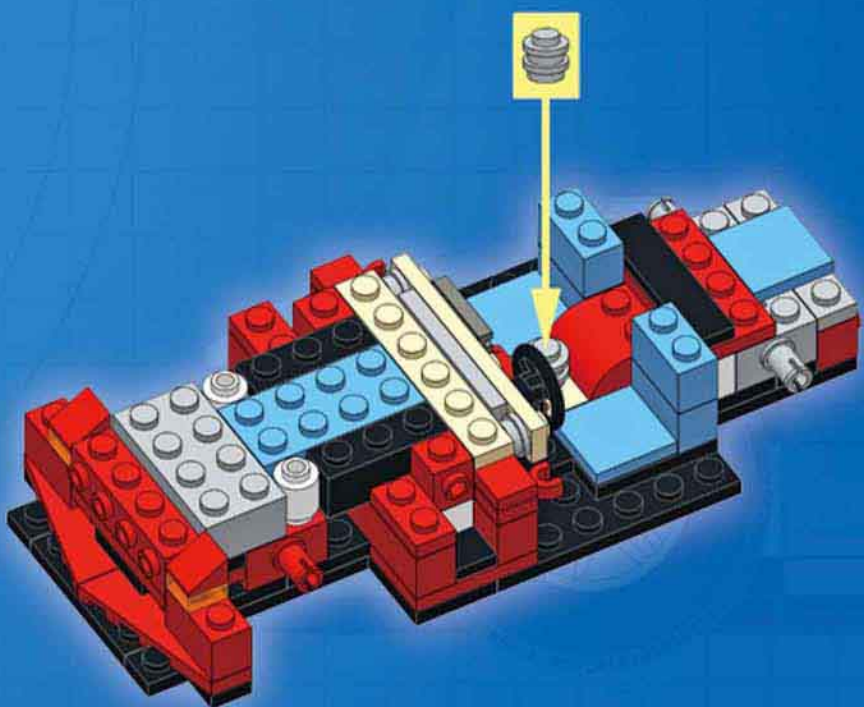

11

- 1x
- 2x
- 1x
- 1x
- 4x
- 4x
- 2x

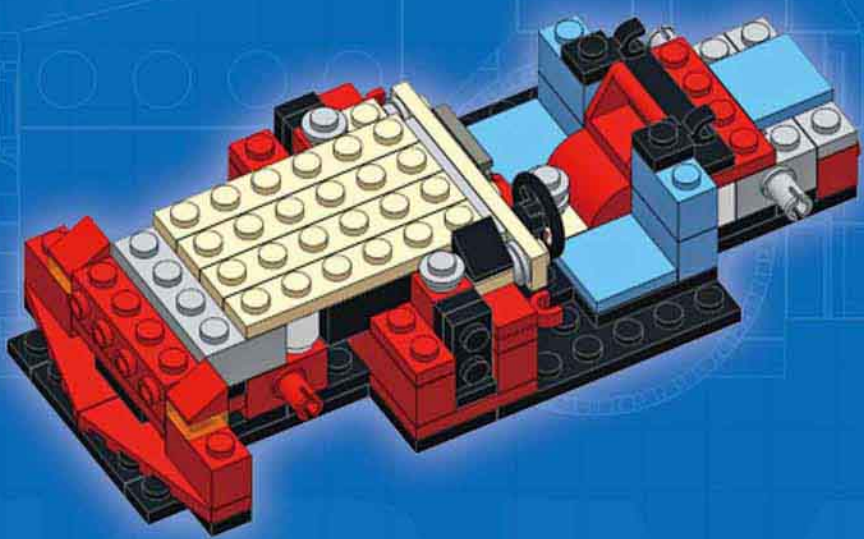



12

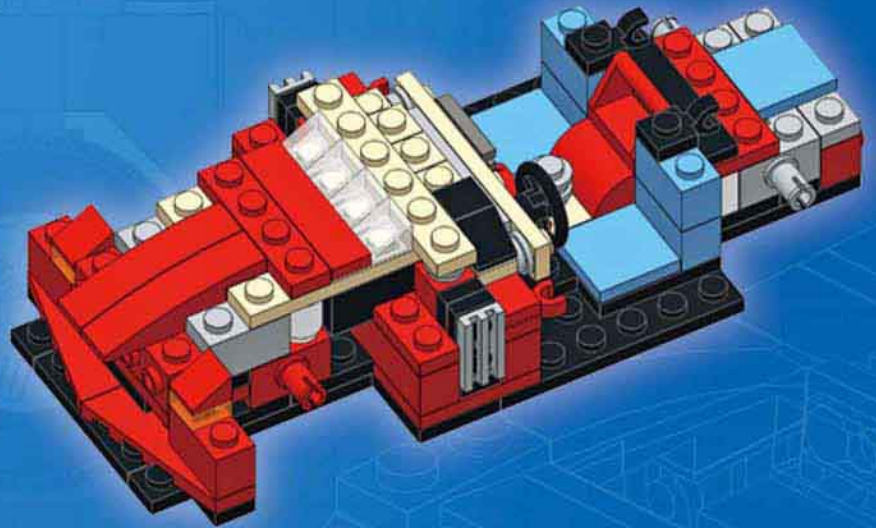
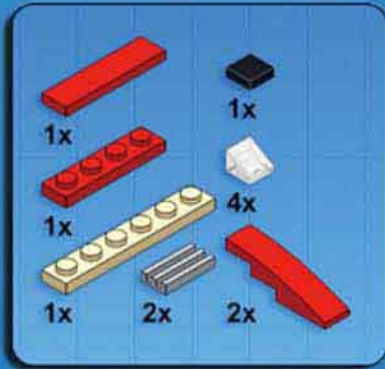

13

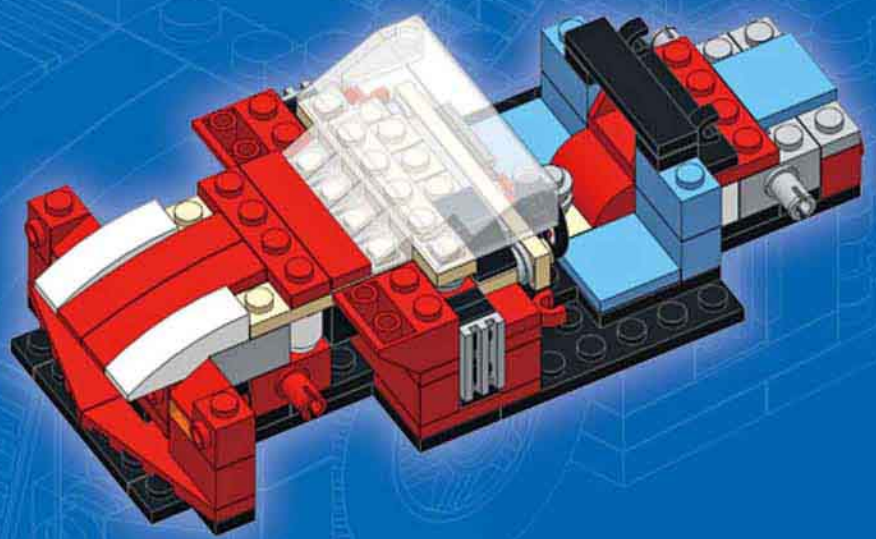
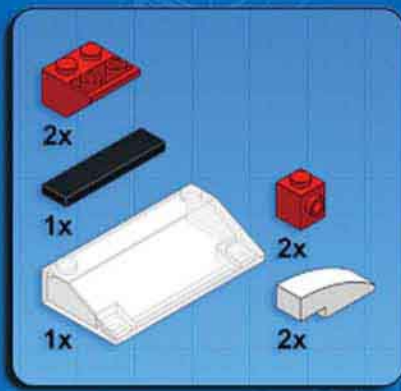



14

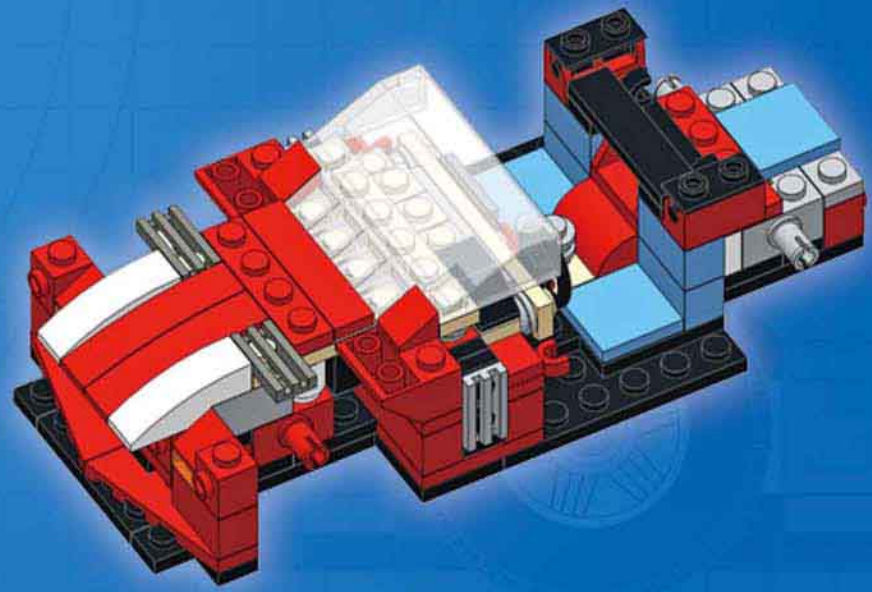
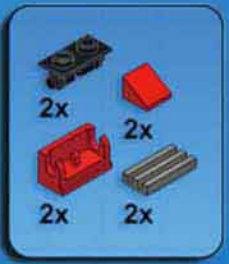

15

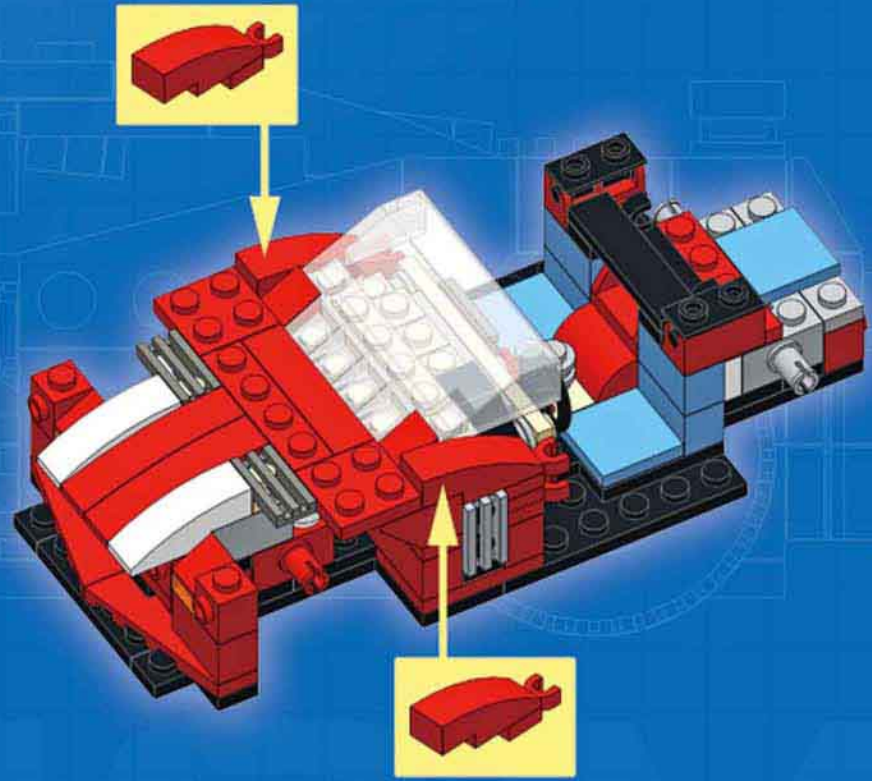
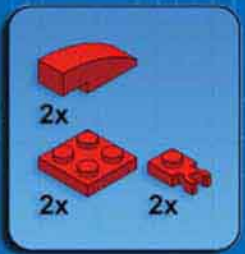



16

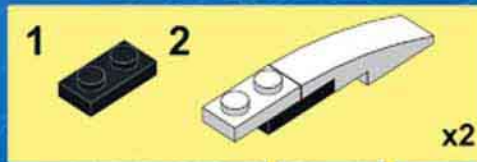
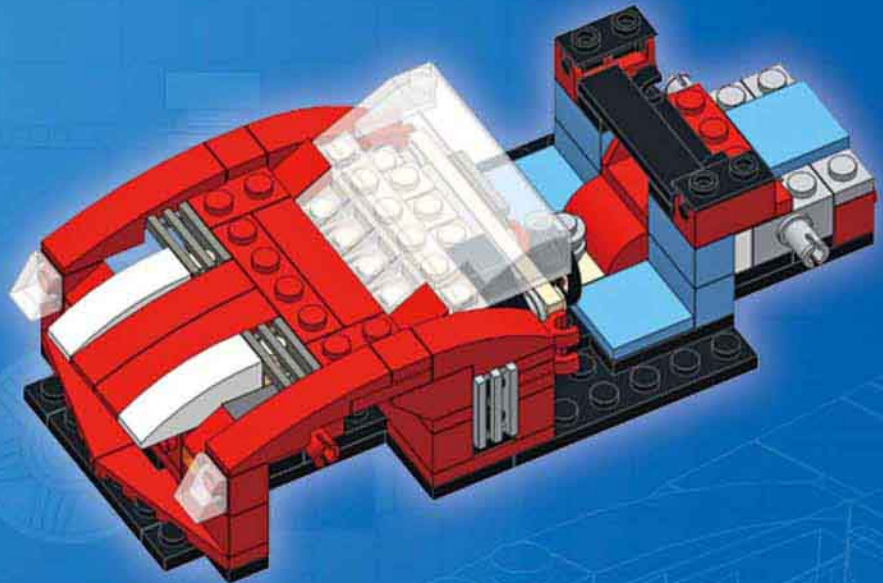
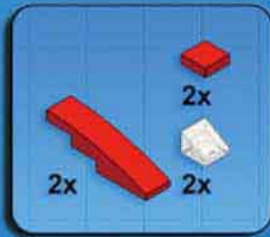

17

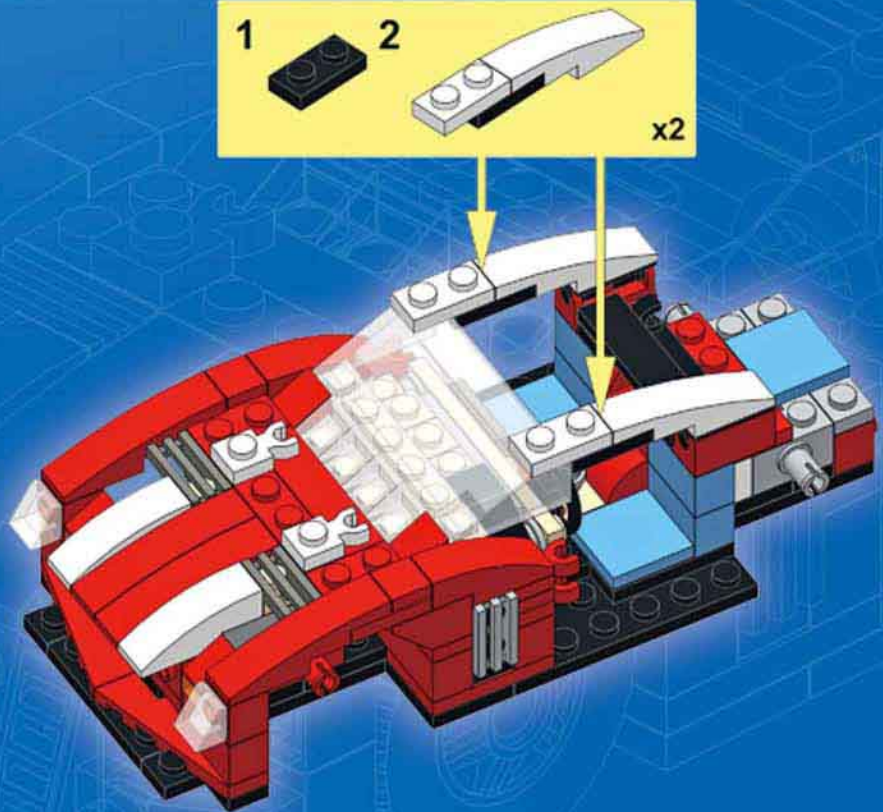



18

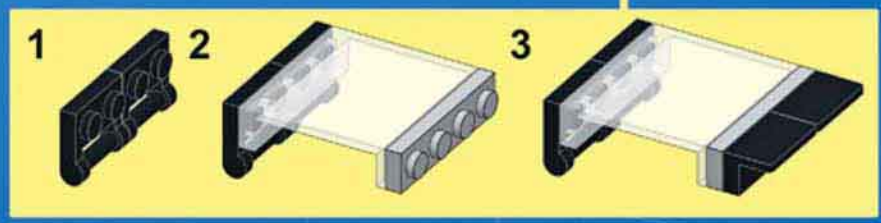
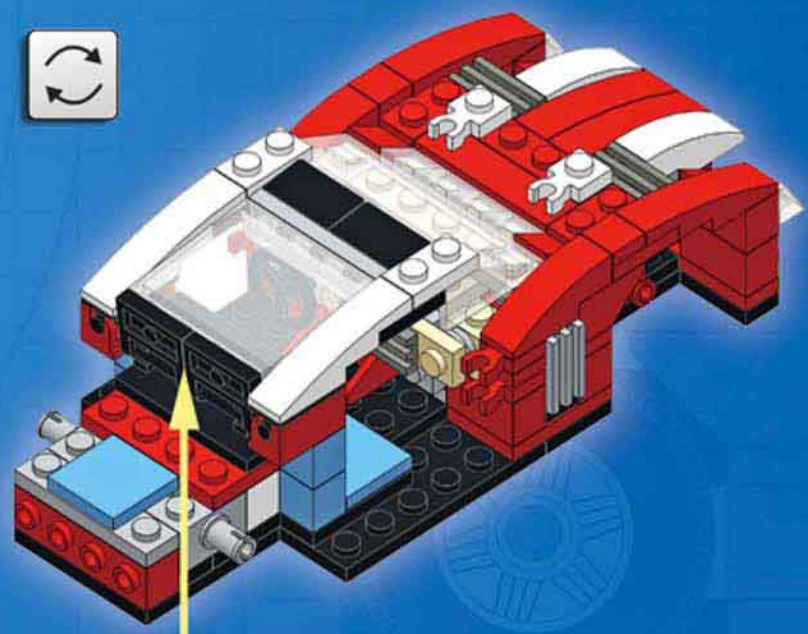
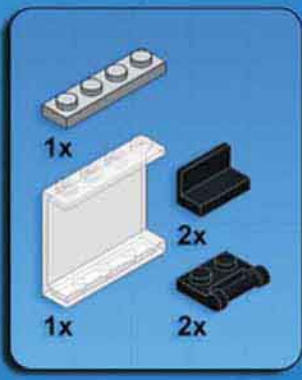

19

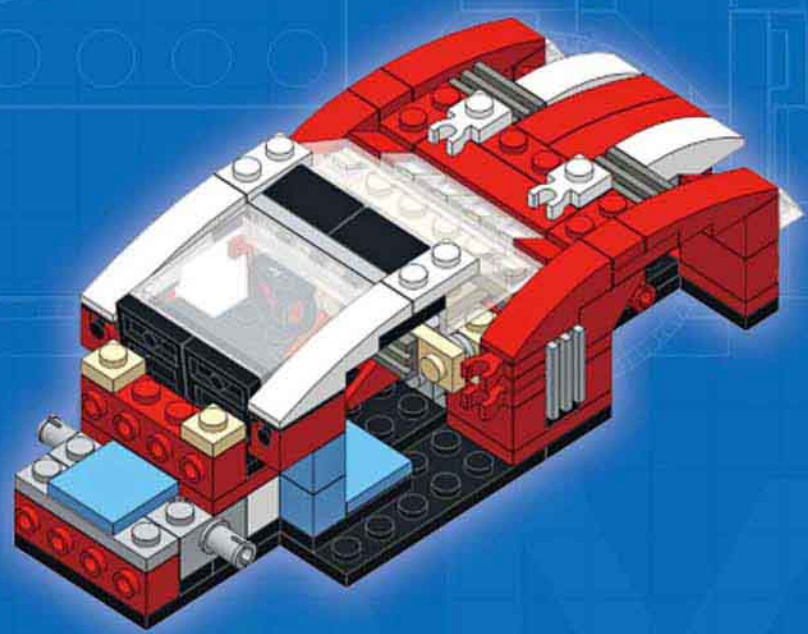
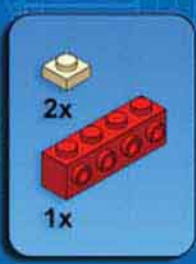





22

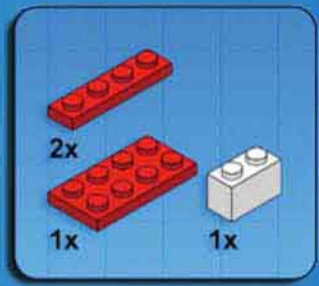

1

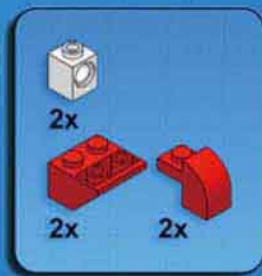
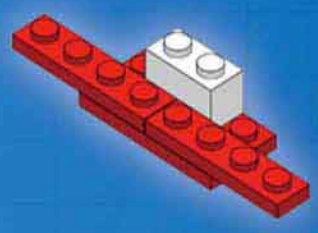

2

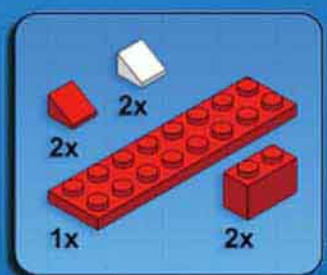
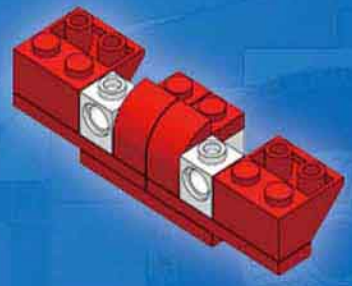

3

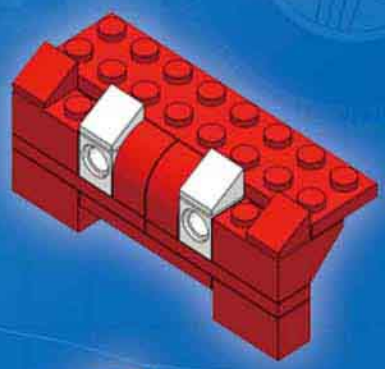

4

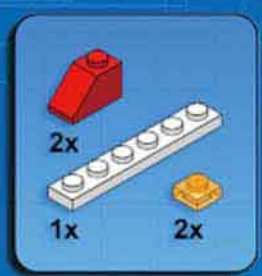
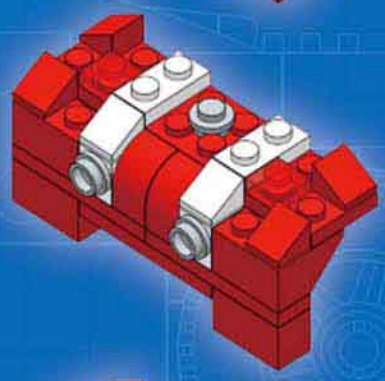

5

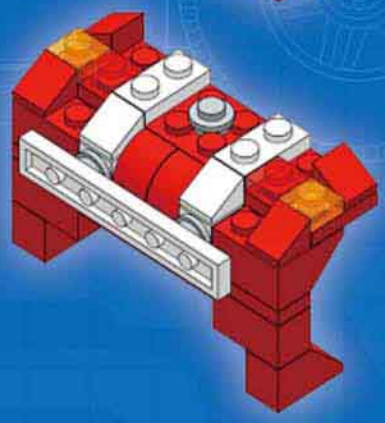



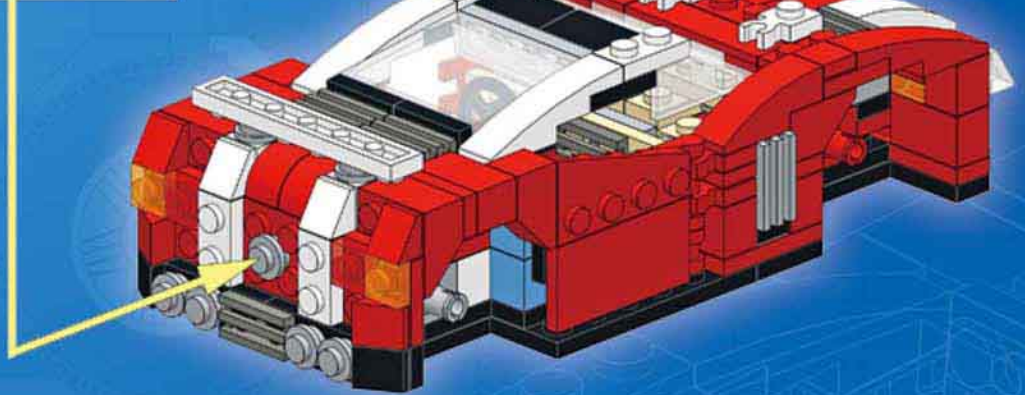
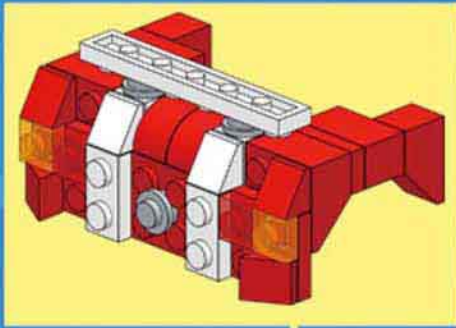

23

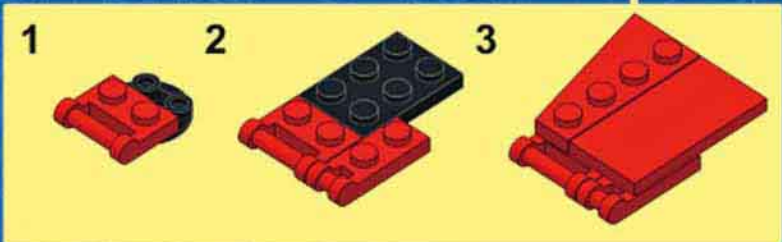
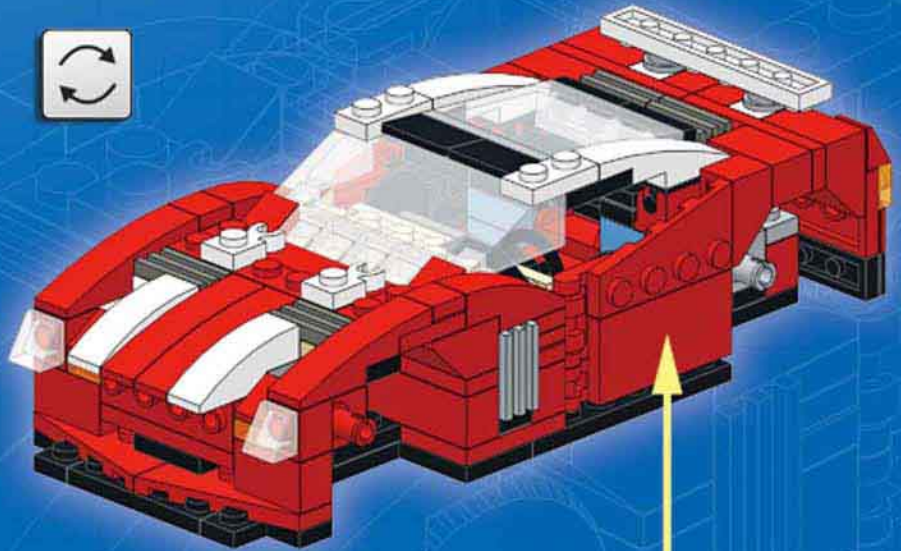
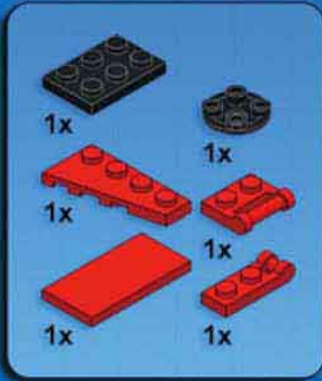





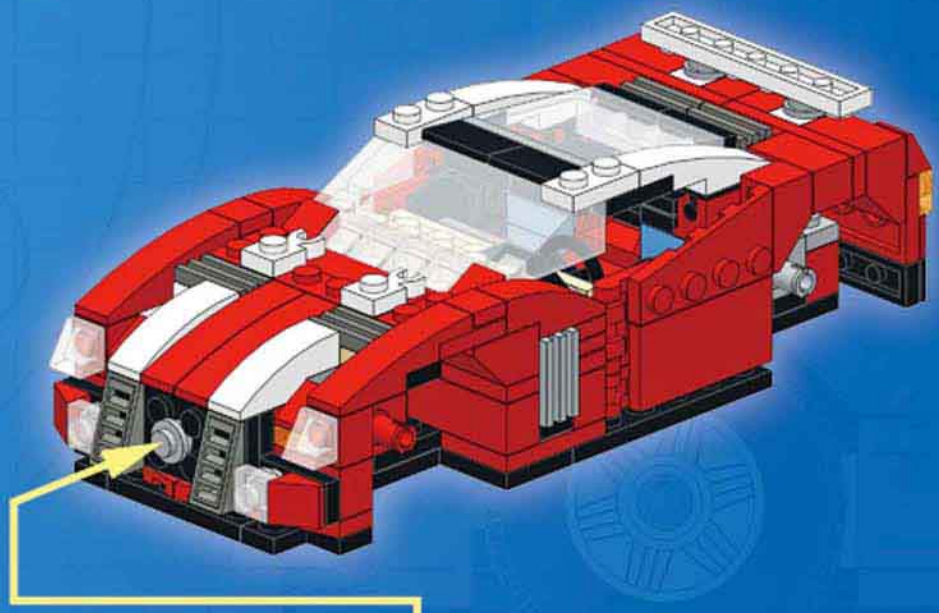
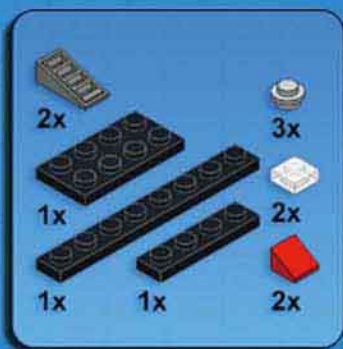

24

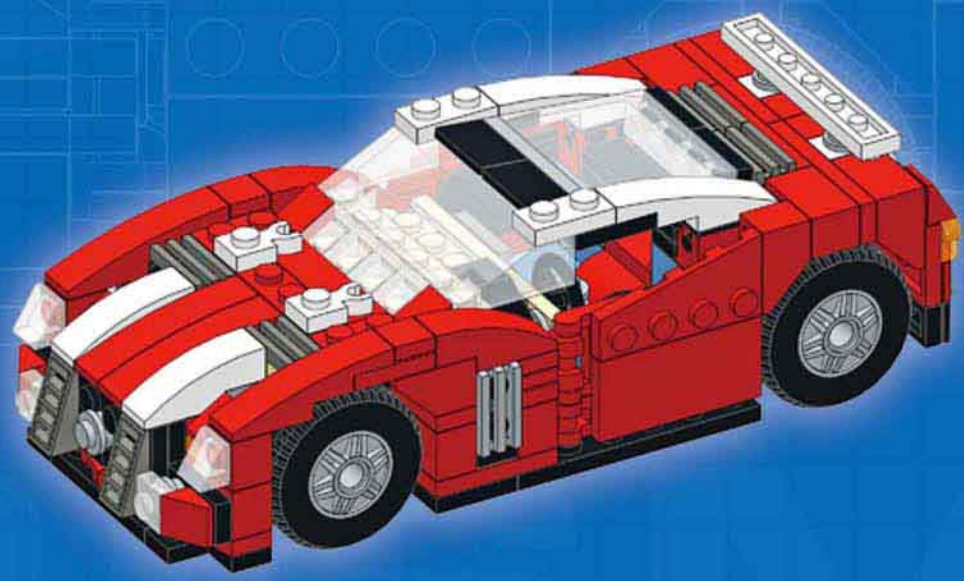

25





Complexity   
 Functions   
 Pieces 

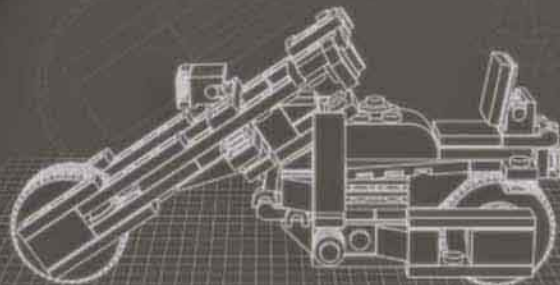
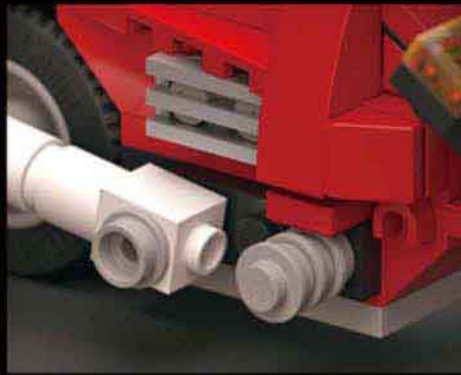

## CHOPPER

Design notes: 4-cylinder engine, high handlebars, big headlight, gas tank, easy rider seat

### Technical specifications:

Dimensions (l × w × h): 18 × 9 × 9 studs  
 Wheelbase: 14 studs  
 Axle width front/rear: 4/3 studs

Features: working steering

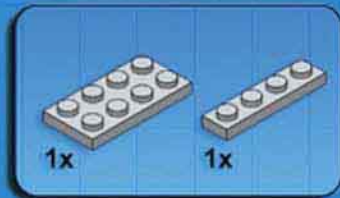

1

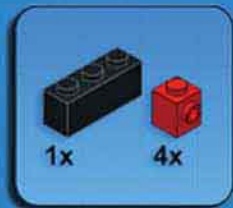

2

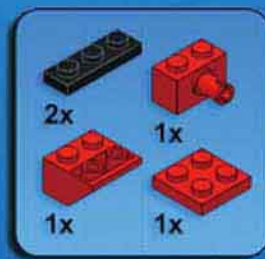
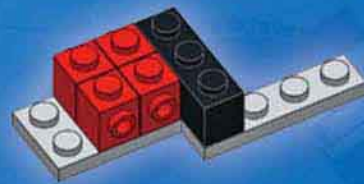

3

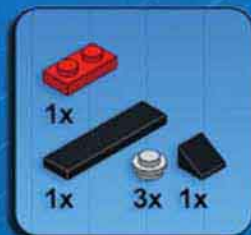
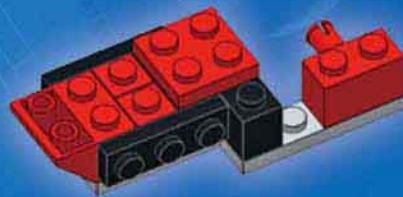

4

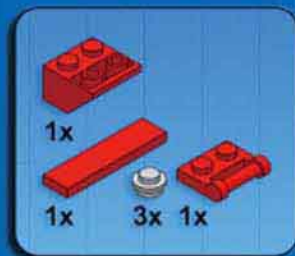

5

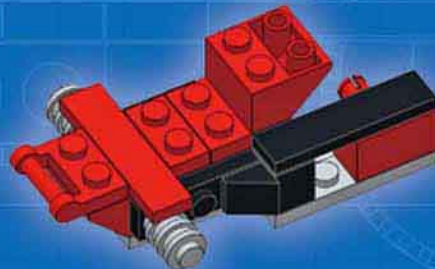



6

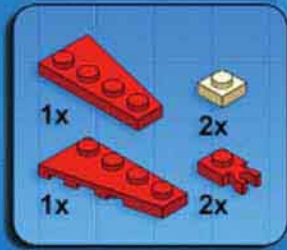
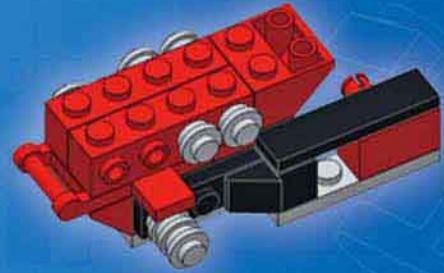

7

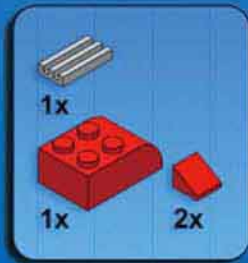
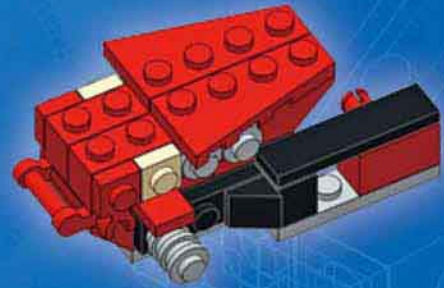

8



9



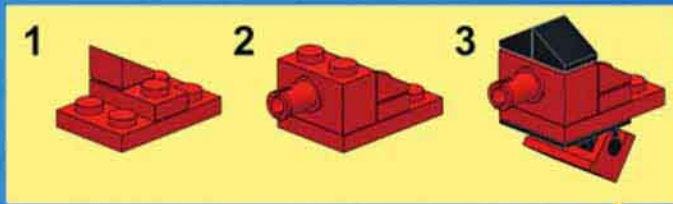

10

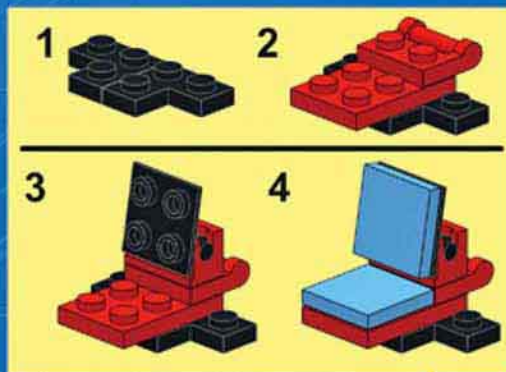
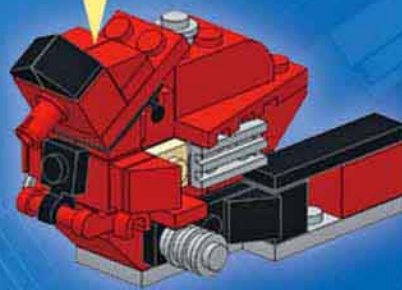
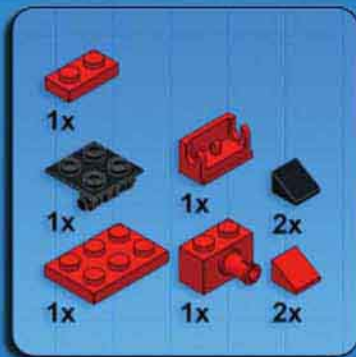

11

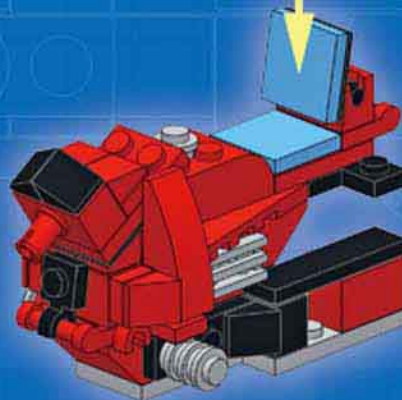
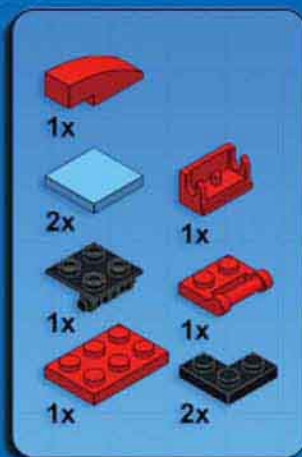

12

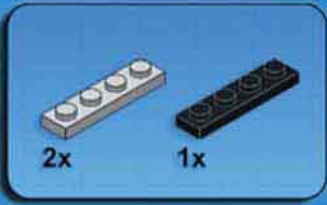

1

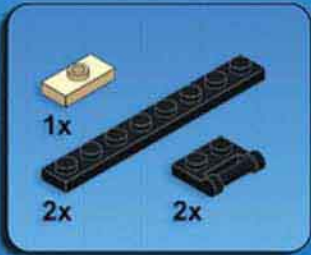

2

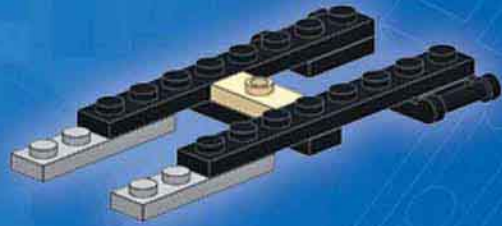

3

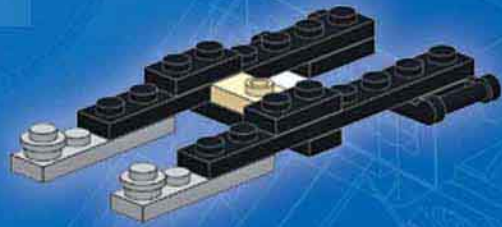

4

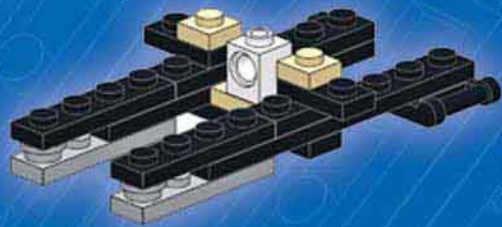

5

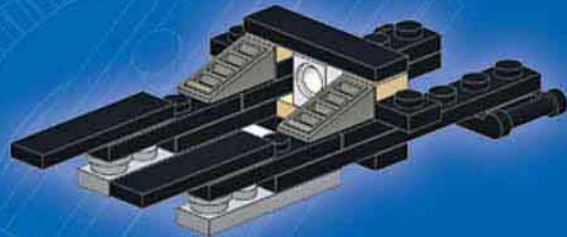



6

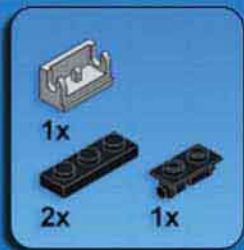
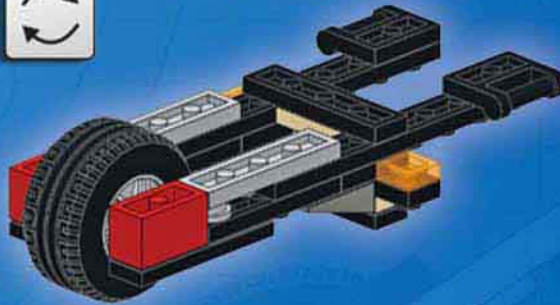

7

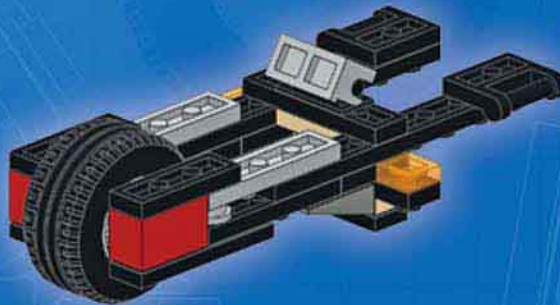

8

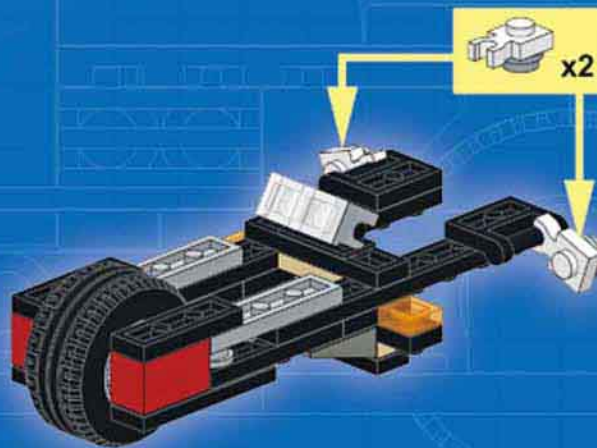



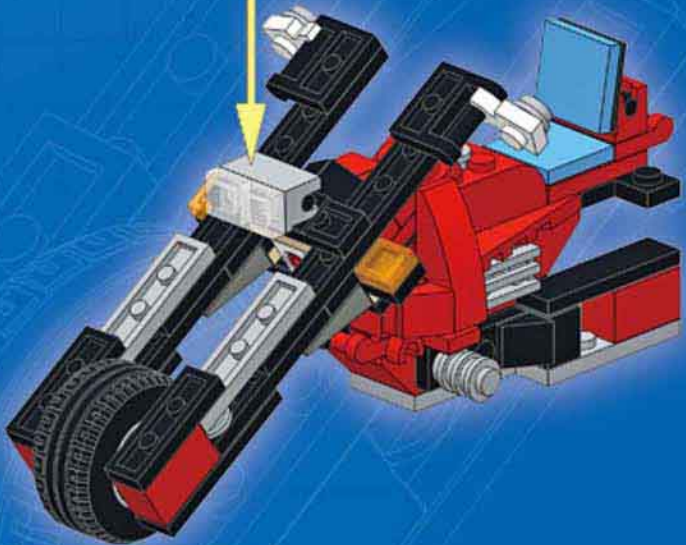
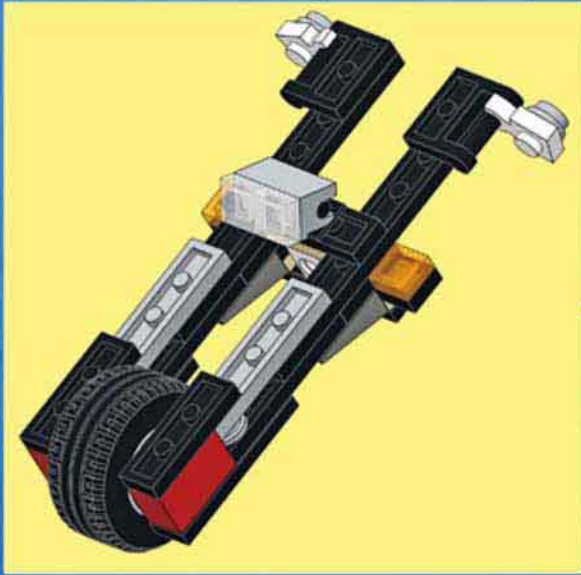



13

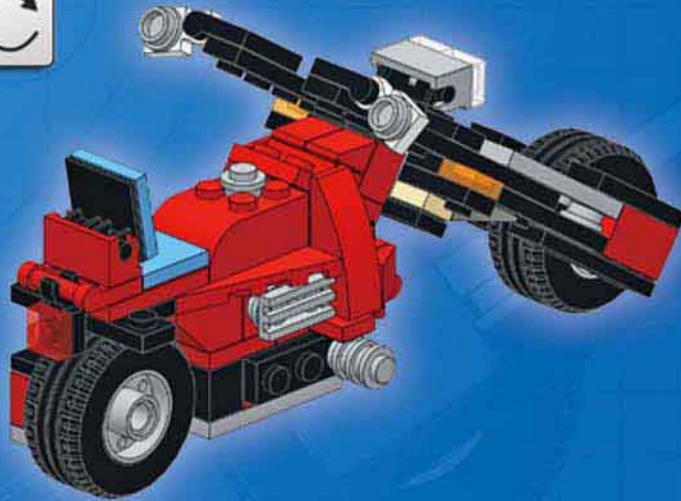

14

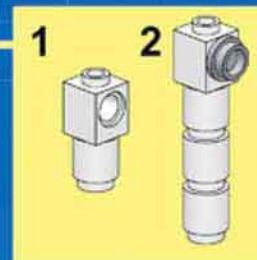
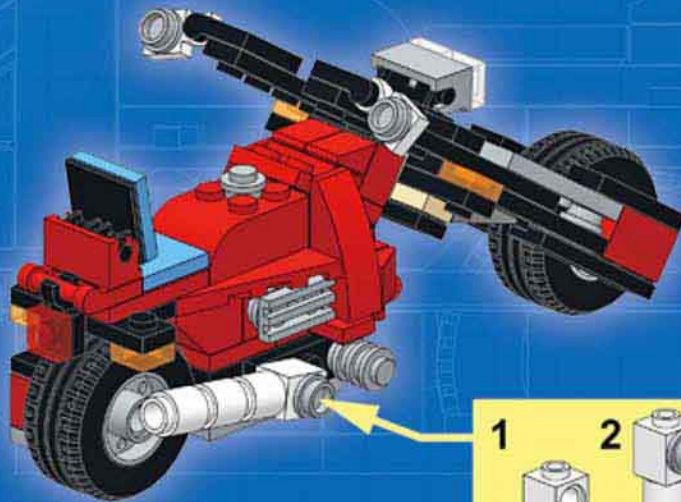



Complexity   
 Functions   
 Pieces 

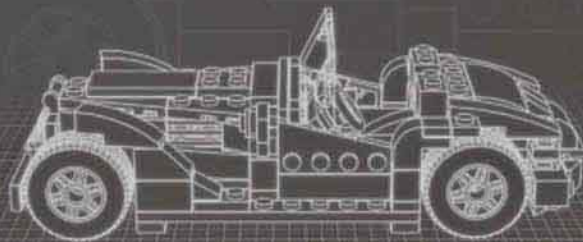
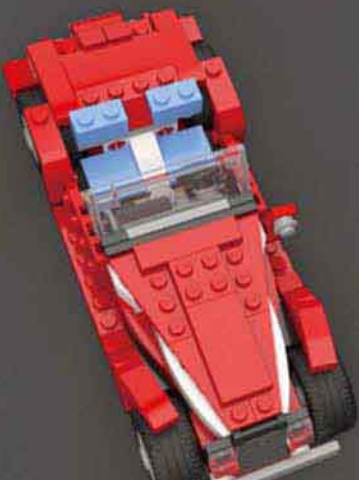
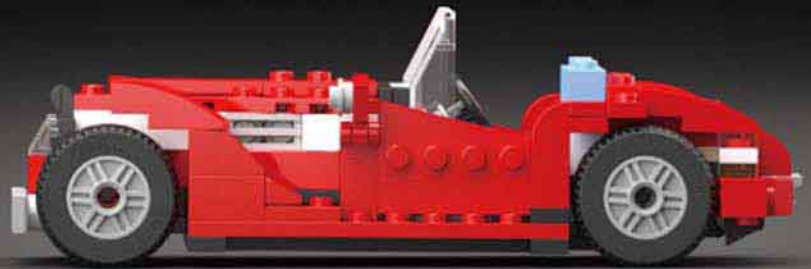
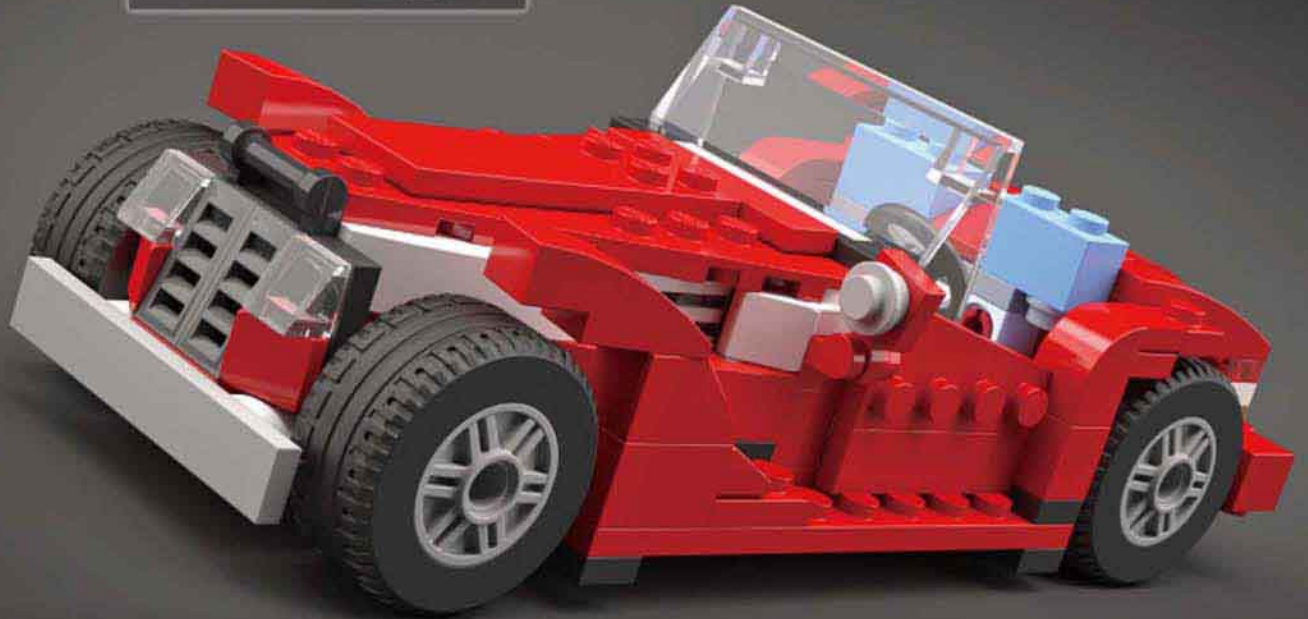

## ROADSTER

Design notes: dramatic curves; open top; long, tapered nose; classic sporty design; detailed interior

### Technical specifications:

Dimensions (l × w × h): 21 × 9 × 7 studs  
 Wheelbase: 14 studs  
 Axle width front/rear: 8/8 studs

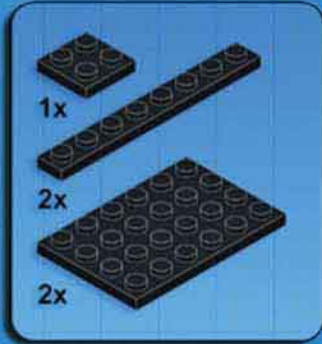

1

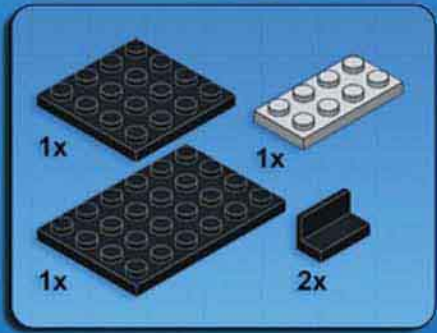
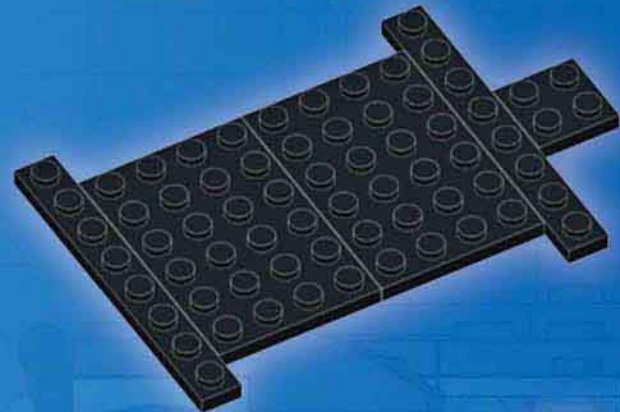

2

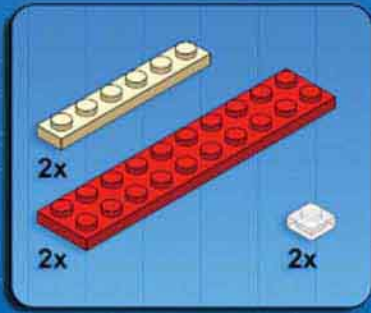
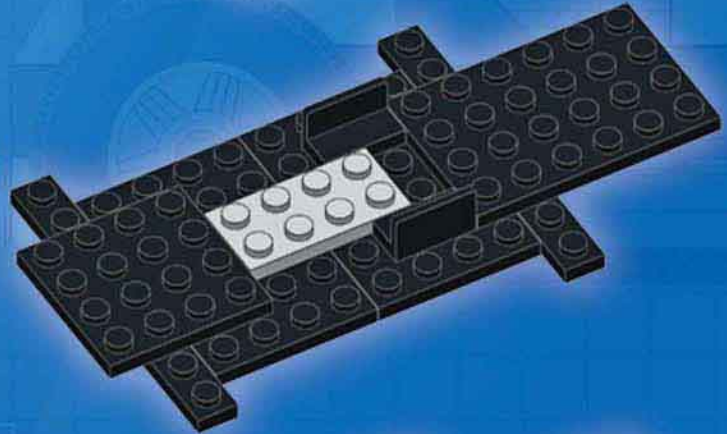

3

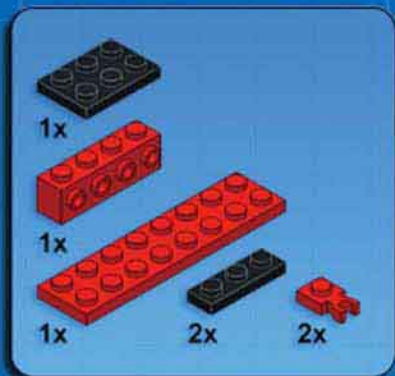
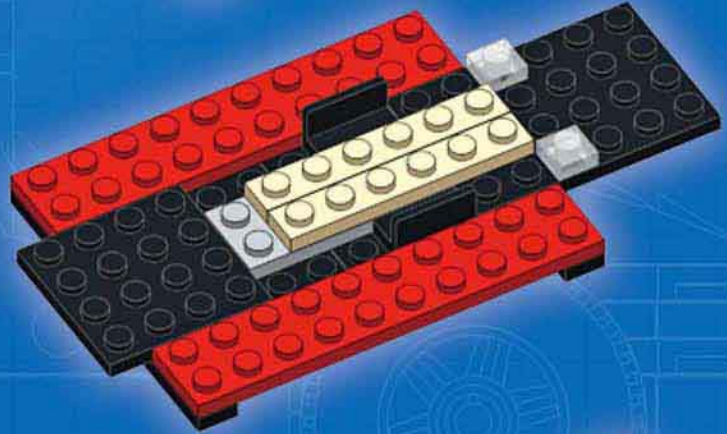

4

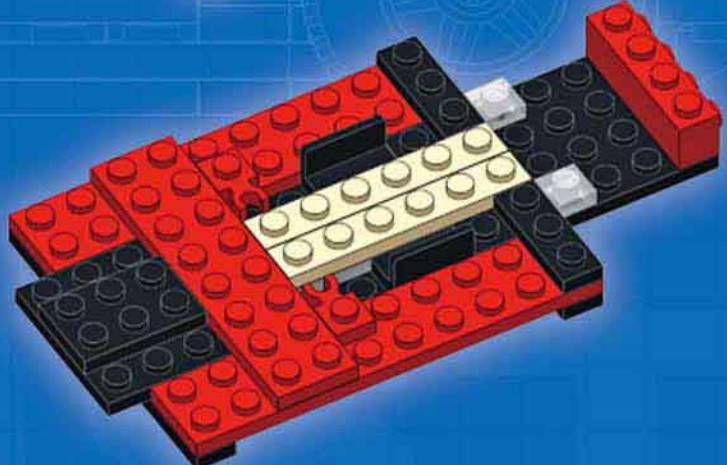

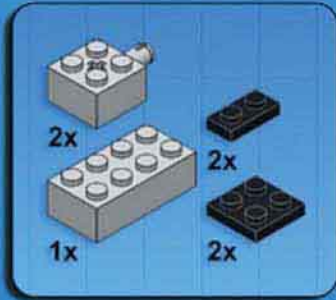

5

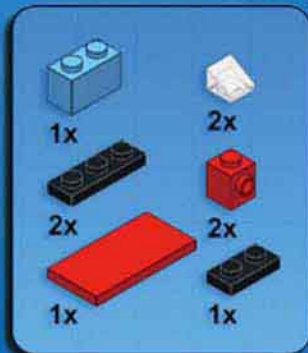
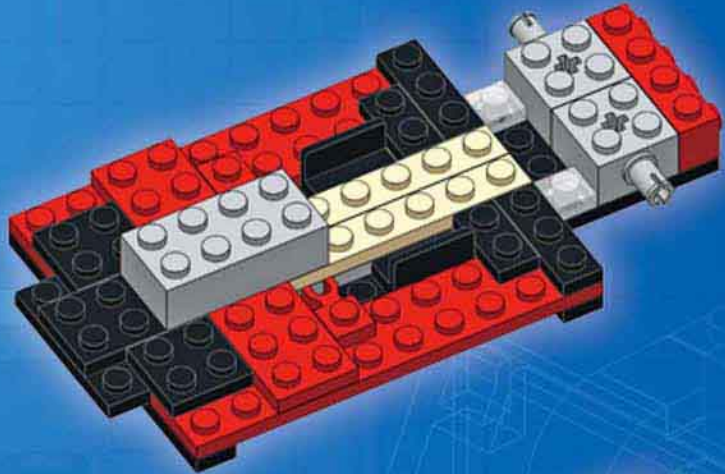

6

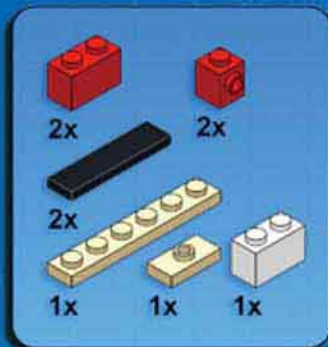
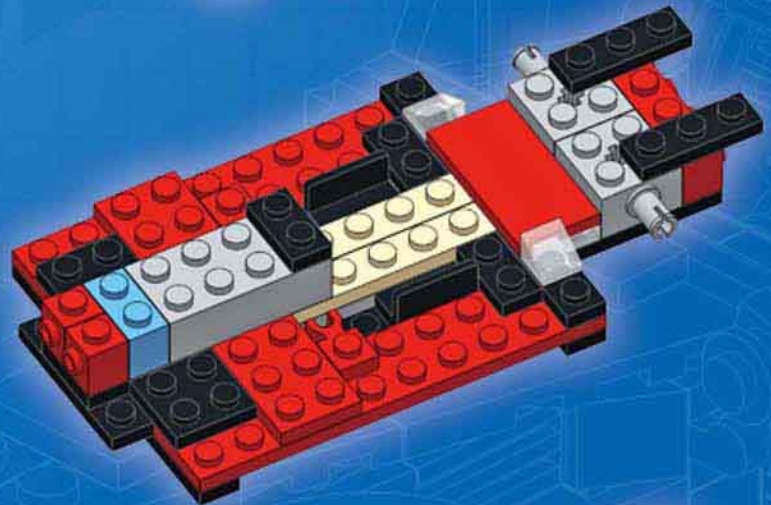

7

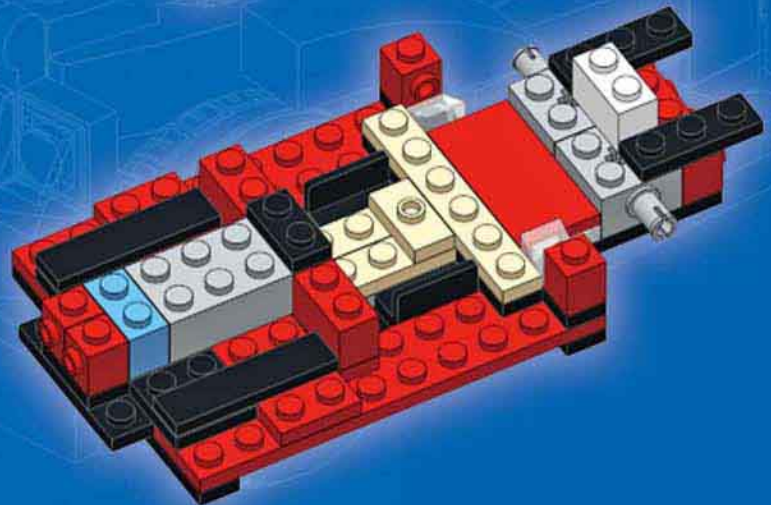



8

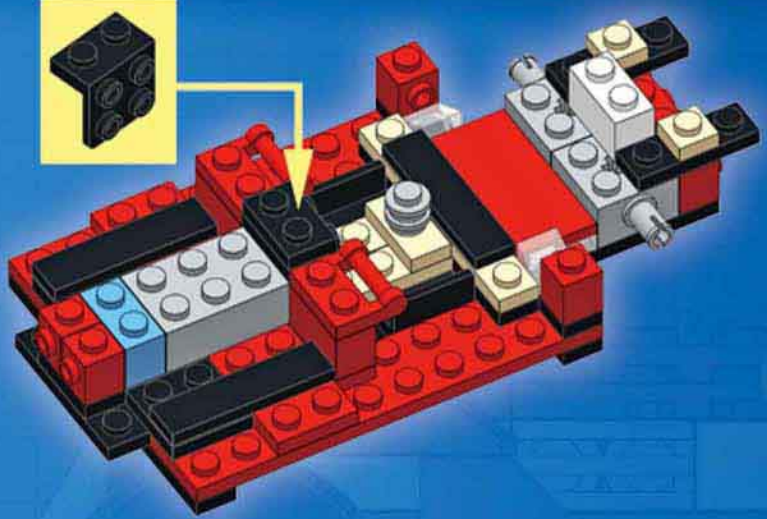
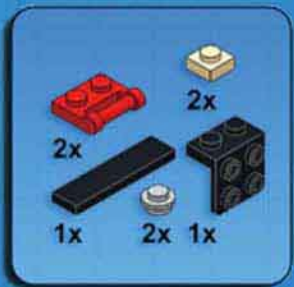

9

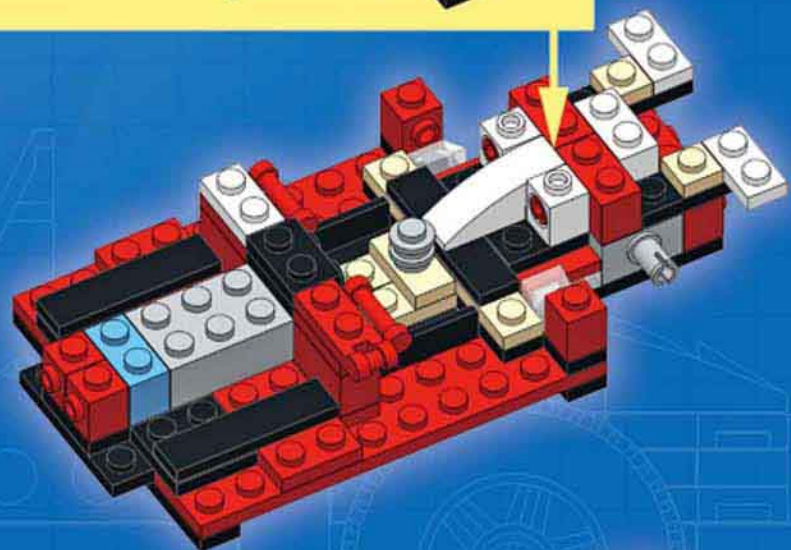
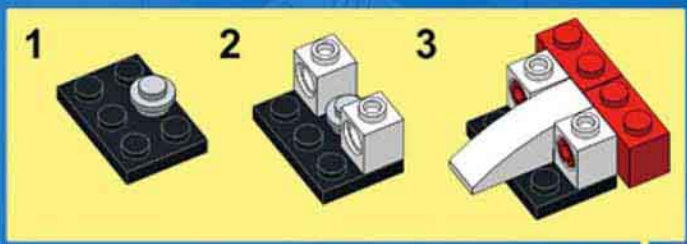

10

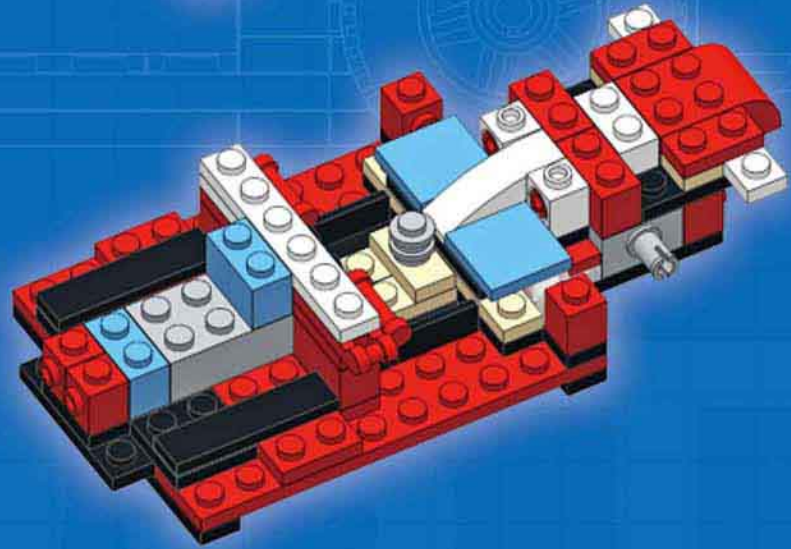
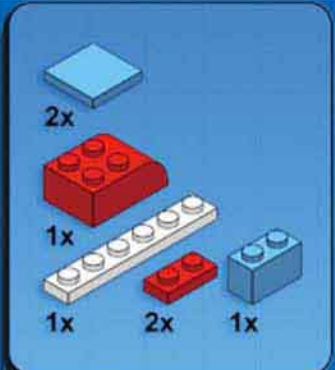

11

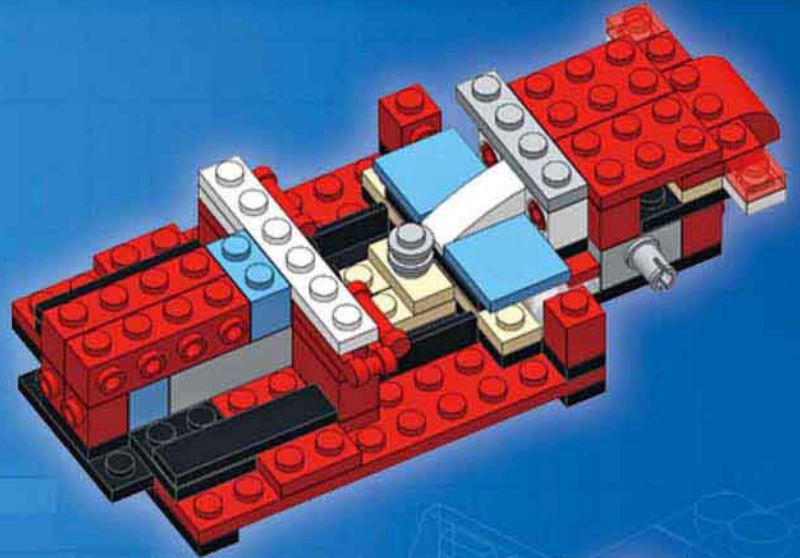
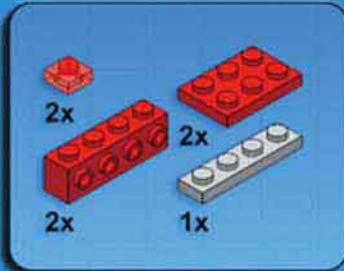

12

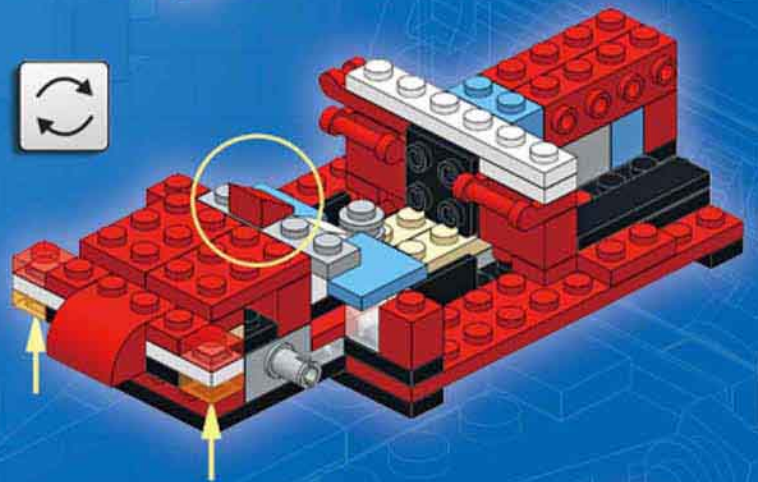

13

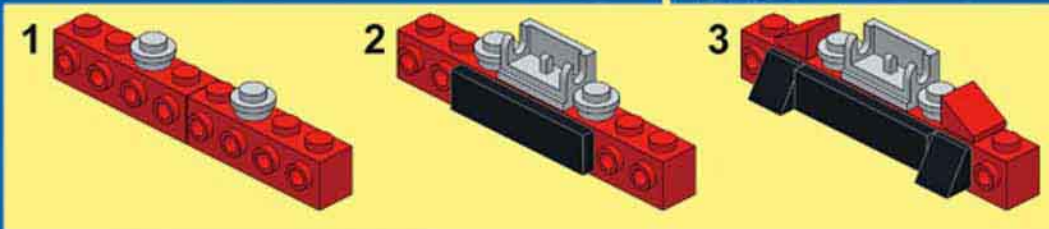
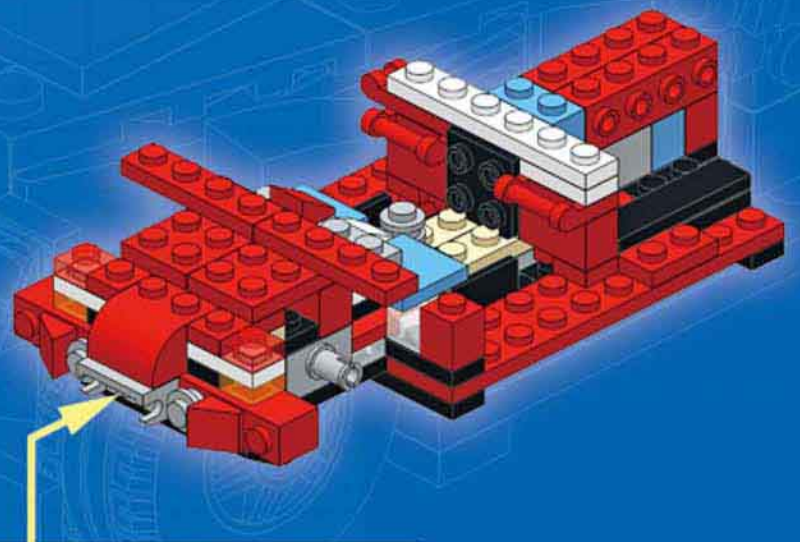
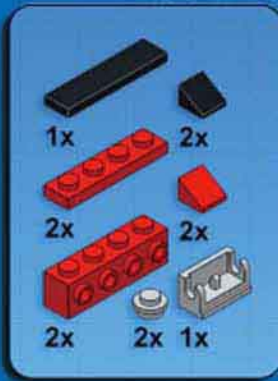



14

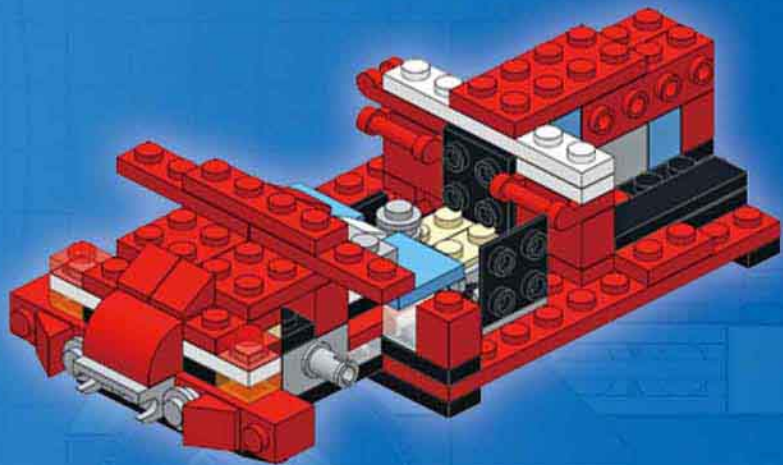
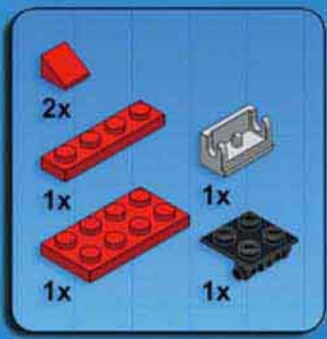

15

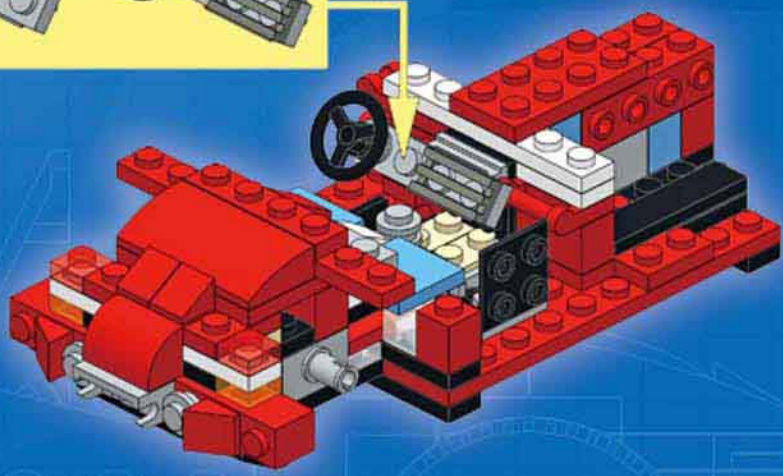
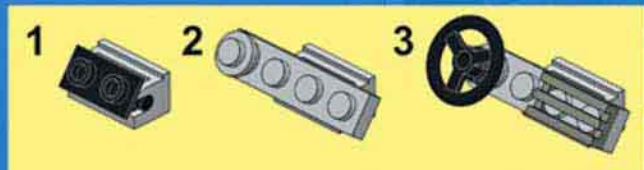

16

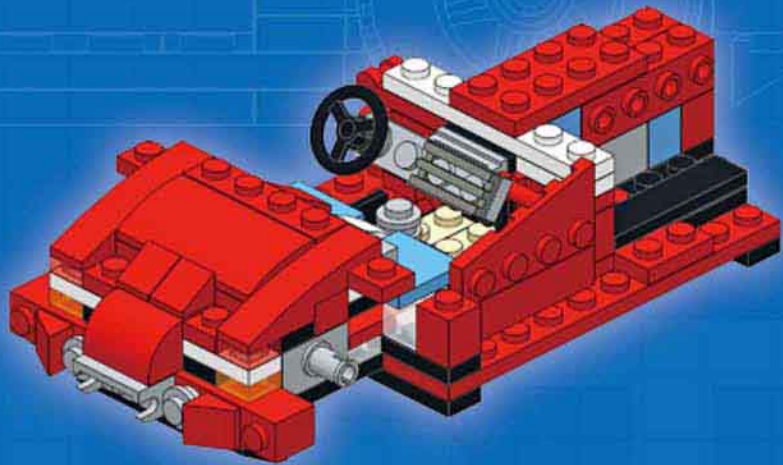
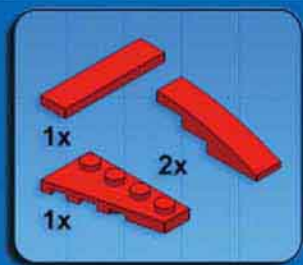





17

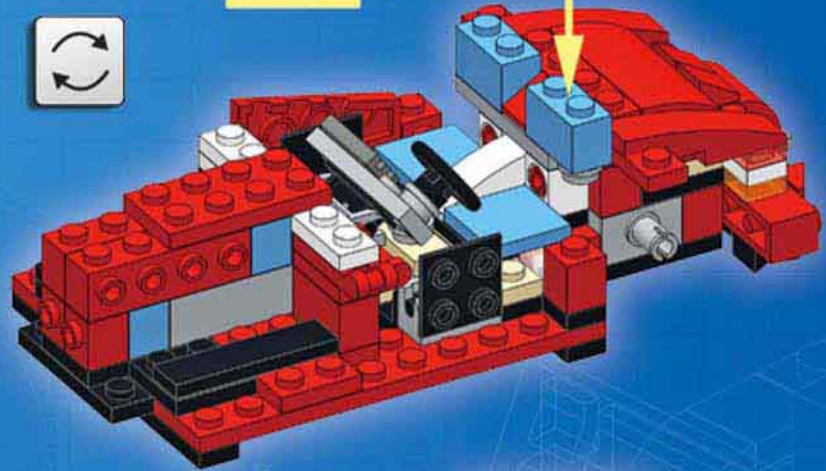

18

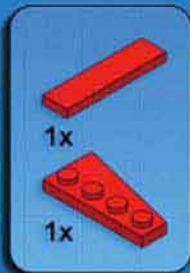
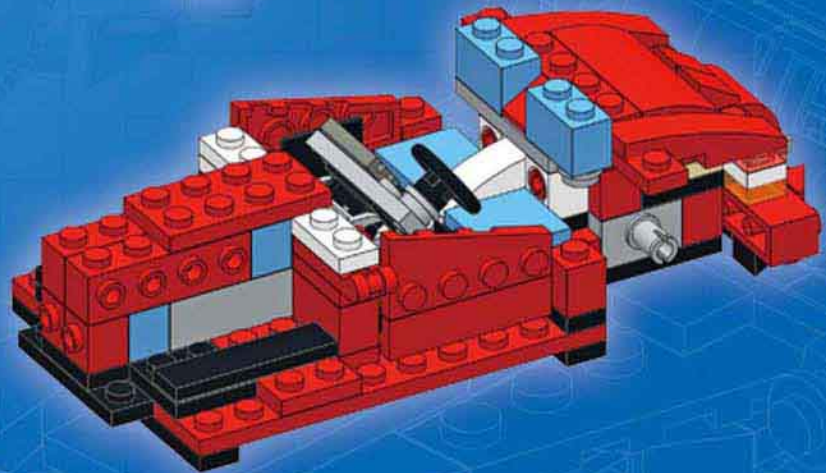

19

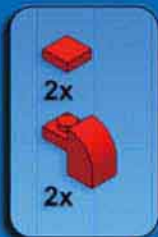
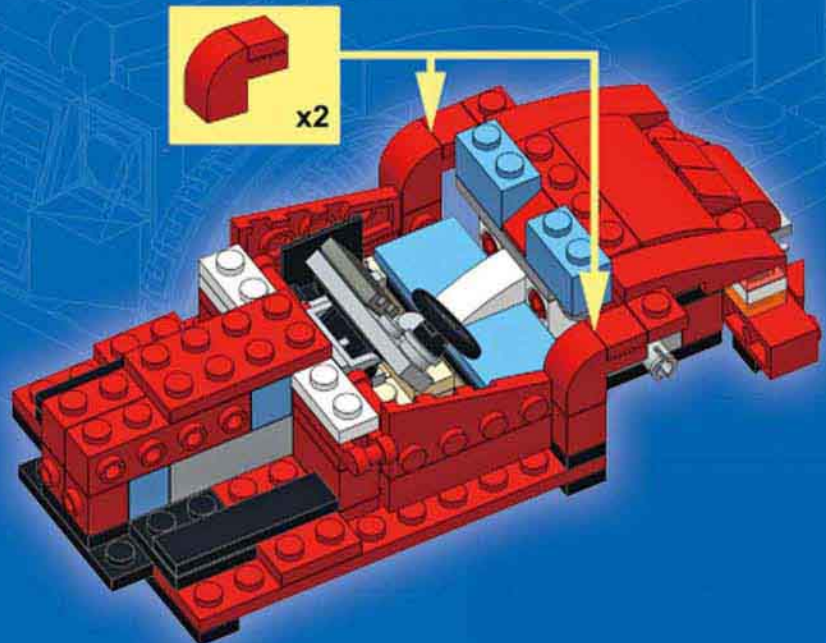



20

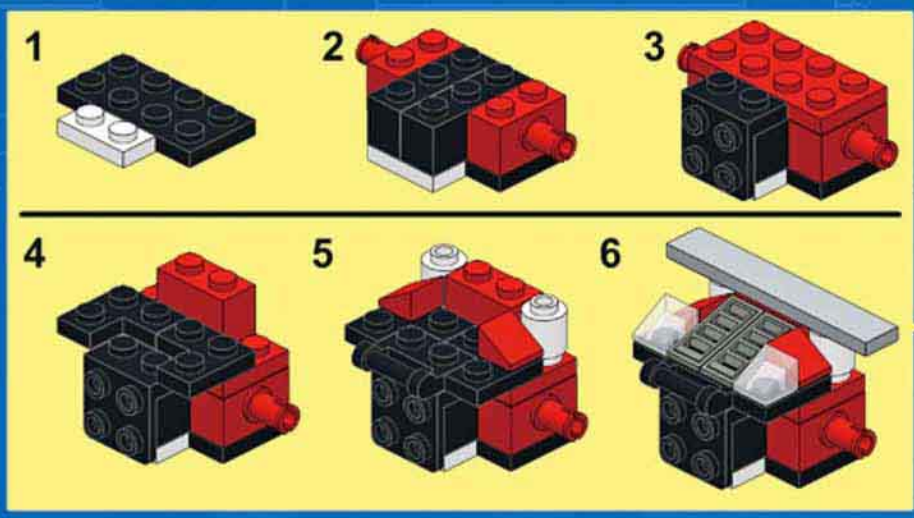
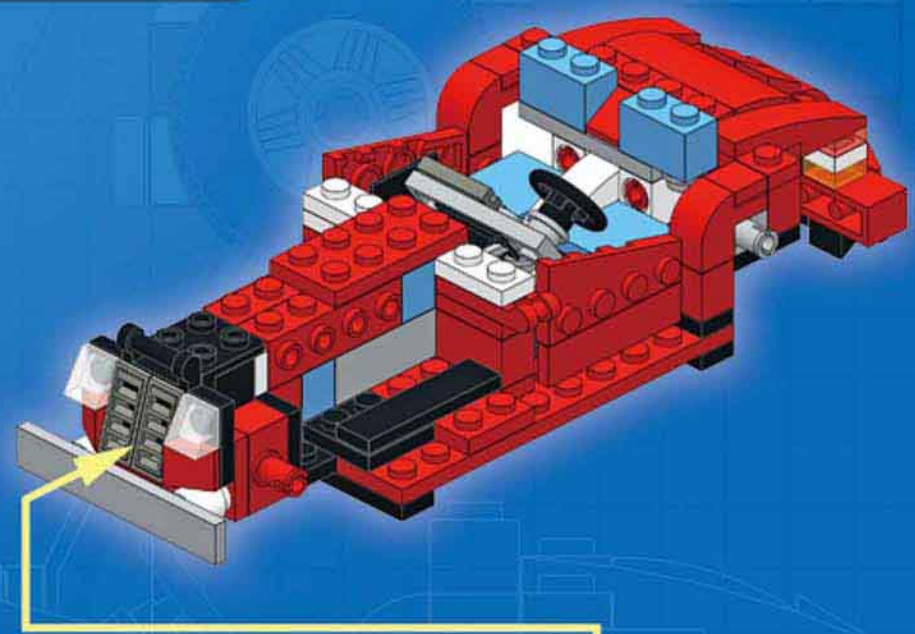
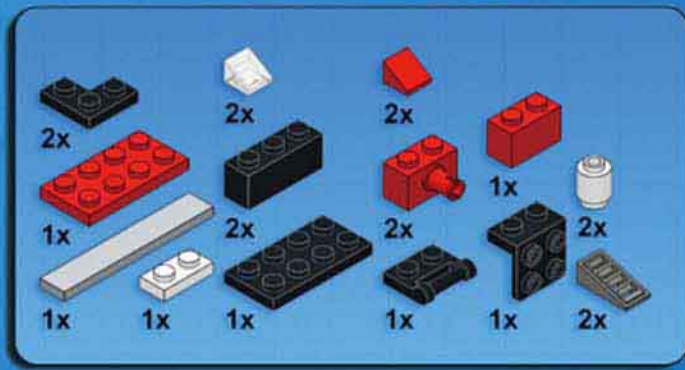



21

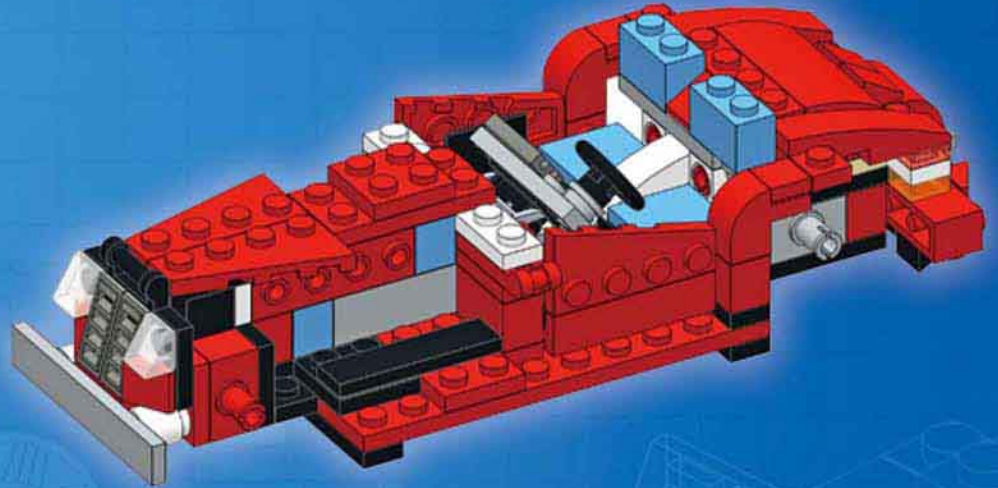
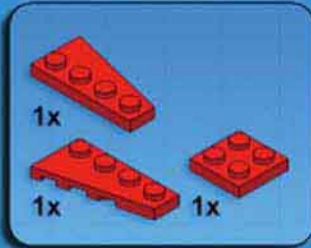

22

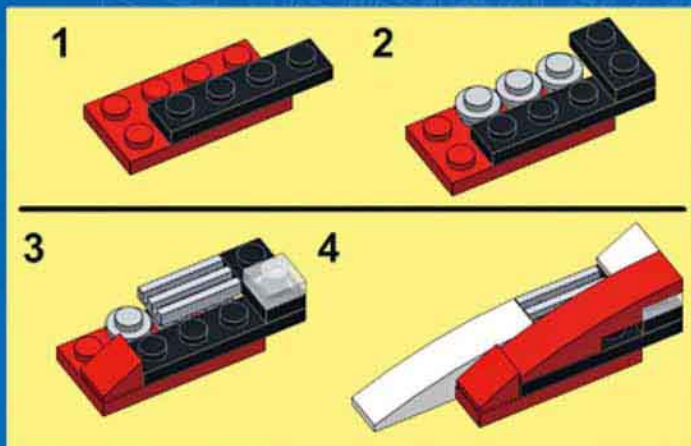
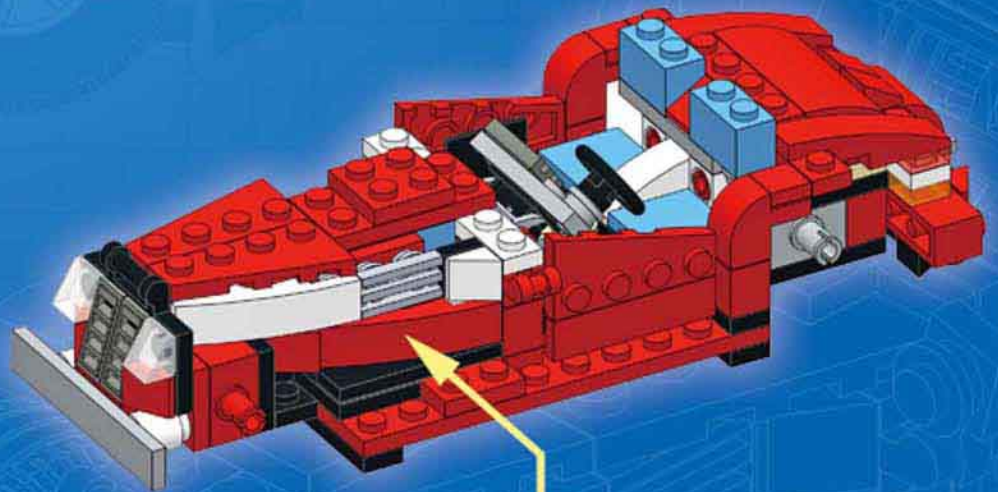
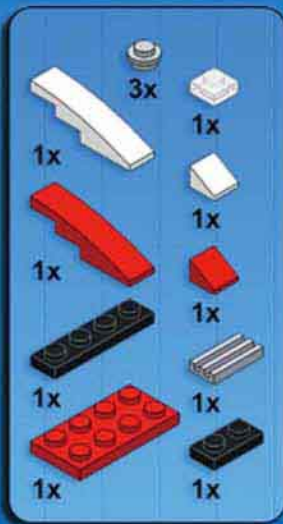



23

- 1x
- 3x
- 1x
- 1x
- 1x
- 1x
- 1x
- 1x
- 1x
- 1x
- 1x

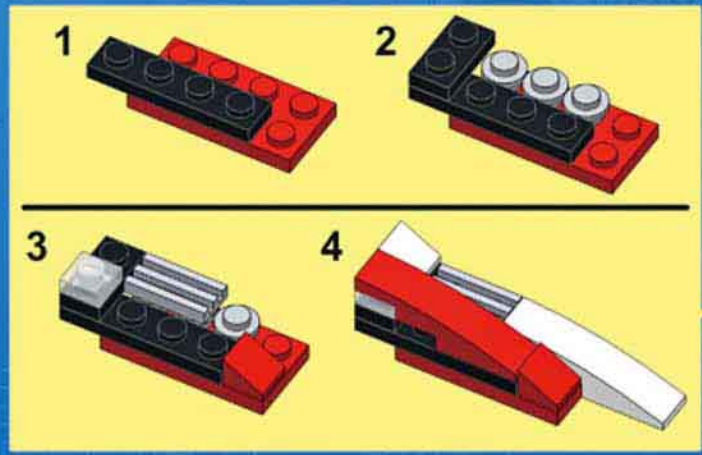
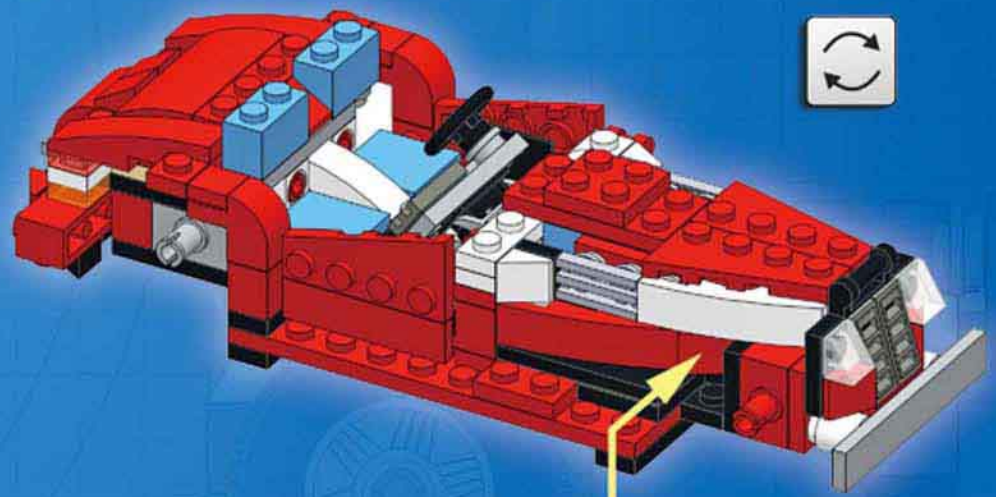

24

- 1x
- 1x
- 1x
- 1x
- 1x

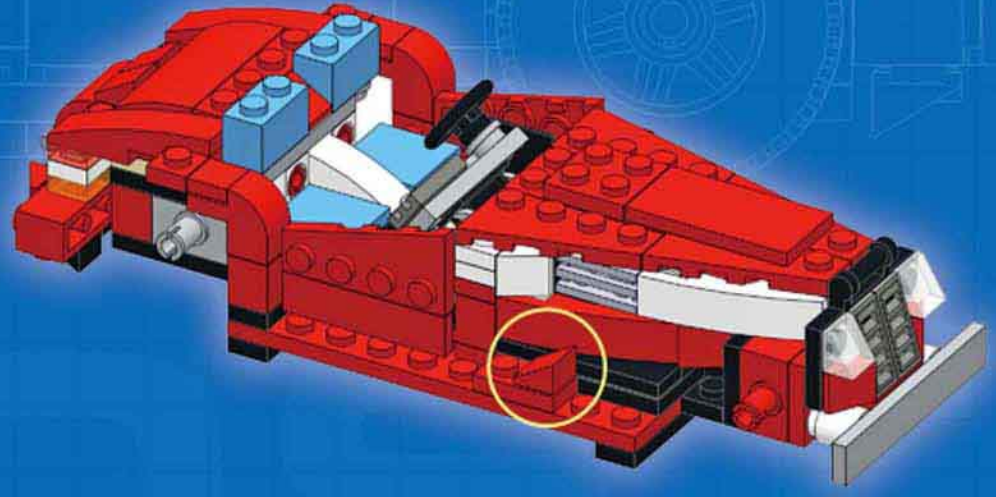



25

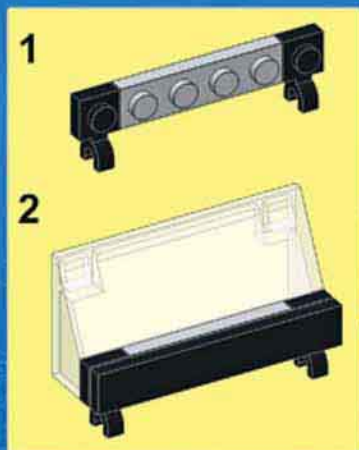
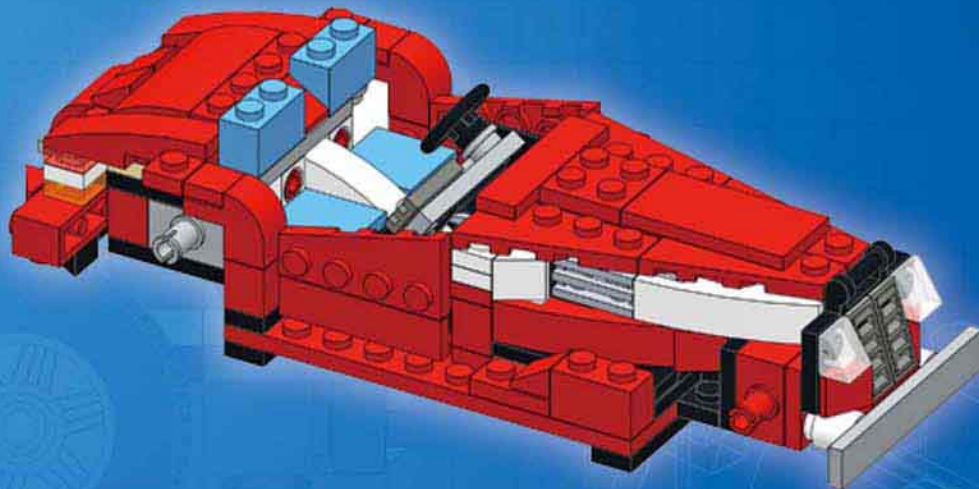
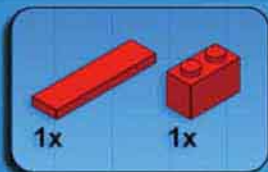

26

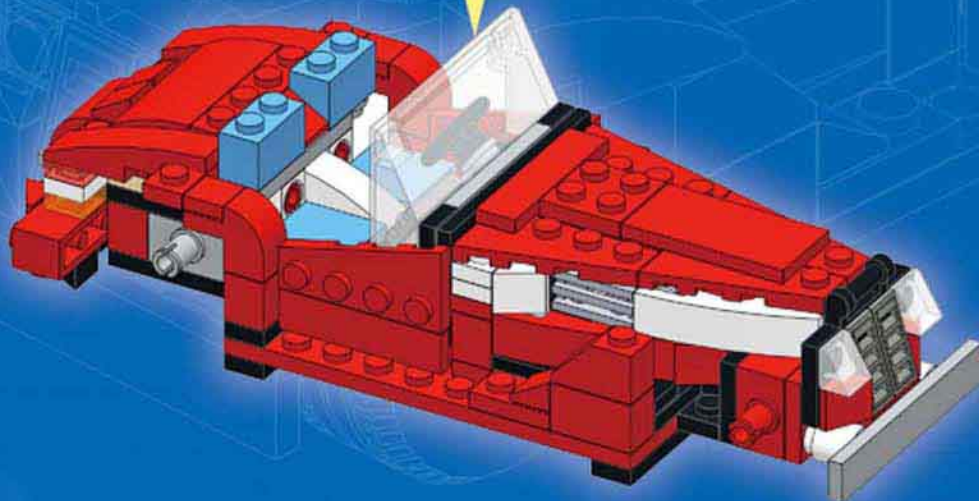
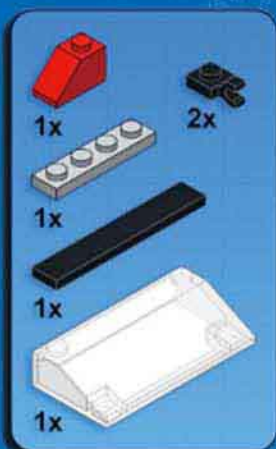



27

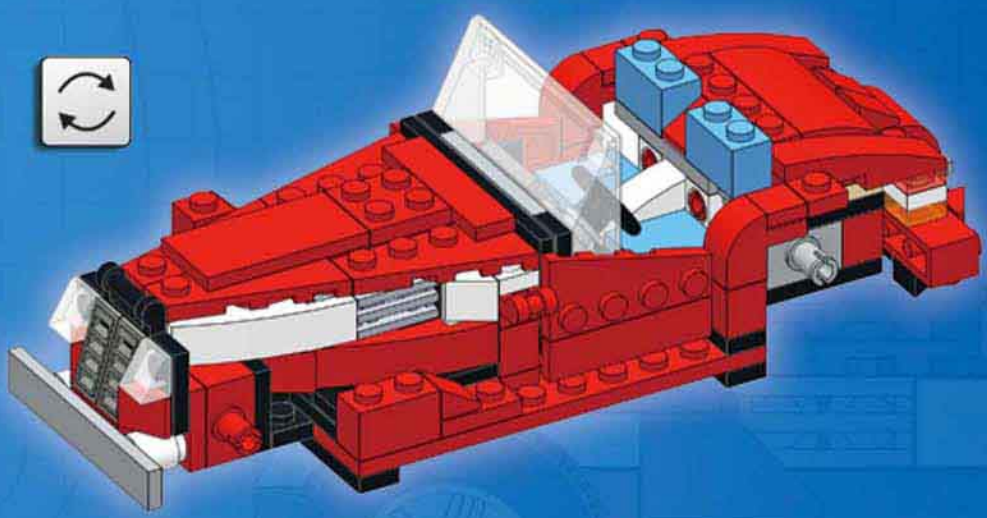
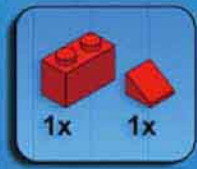

28

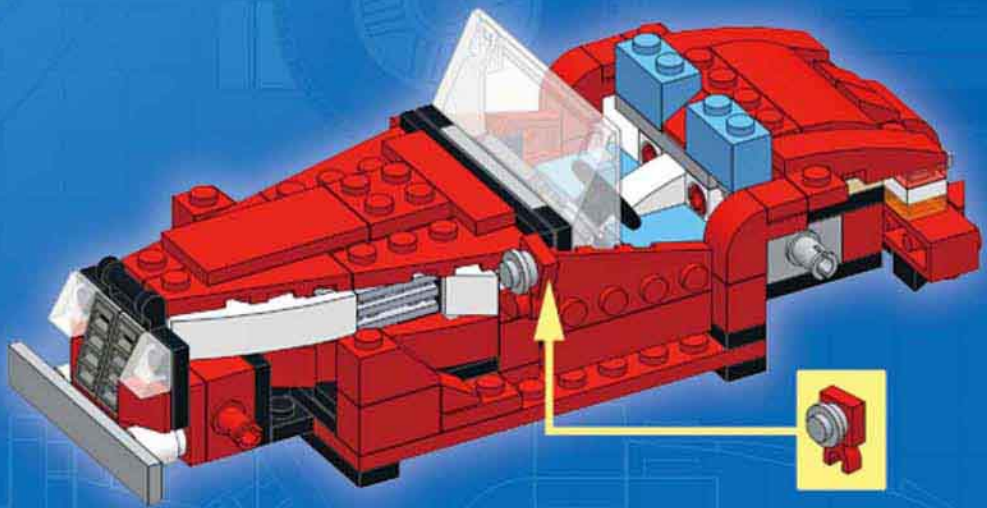

29

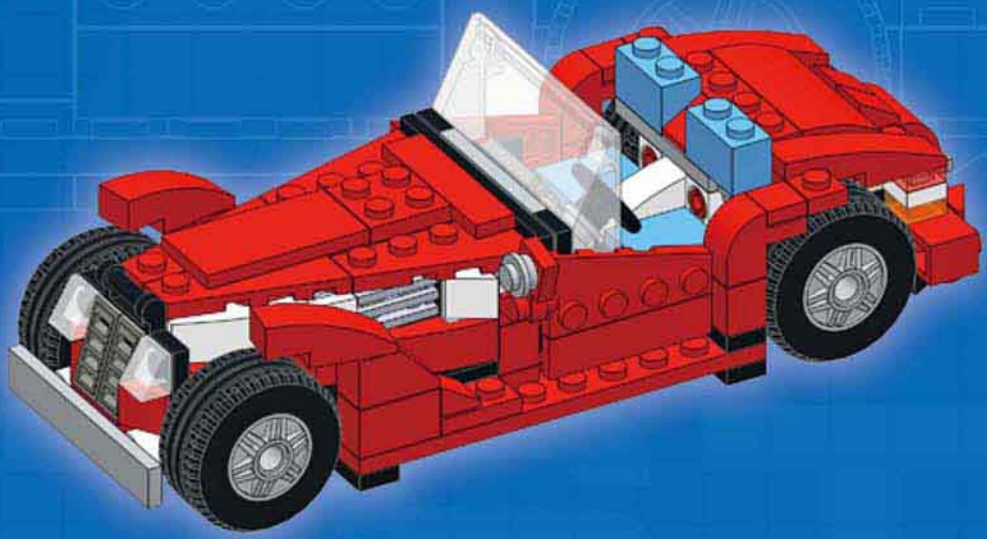



Complexity   
Functions   
Pieces 

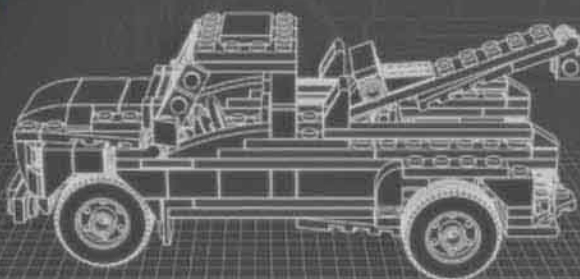
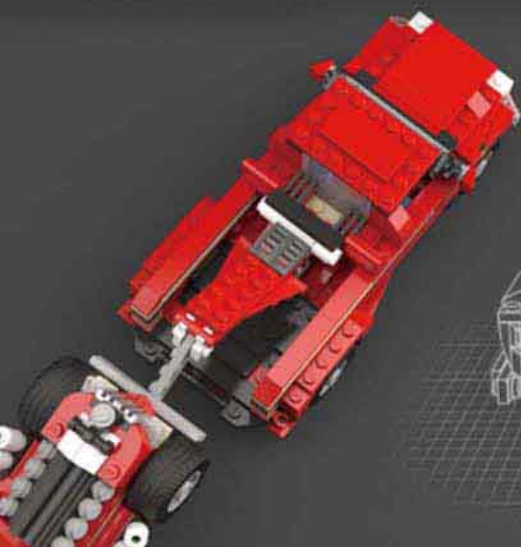
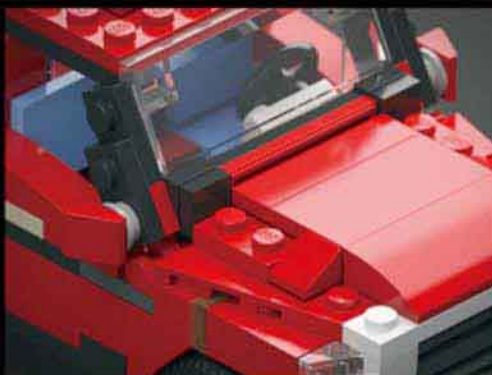

## WRECKER

Design notes: long wheelbase, high clearance, flat bed, wide rear axle, massive grille, livery lines

### Technical specifications:

Dimensions (l x w x h): 23 x 10 x 11 studs  
Wheelbase: 14 studs  
Axle width front/rear: 8/10 studs

Features: lifting crane

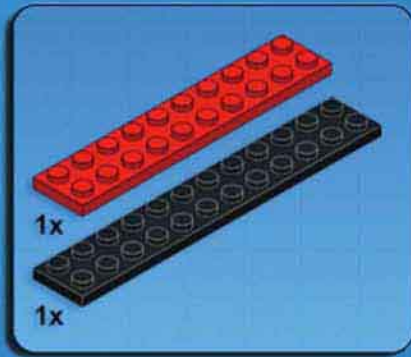
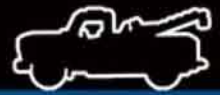

1

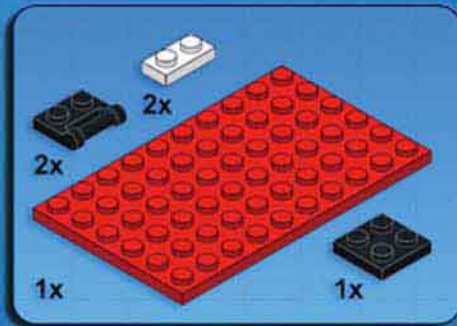
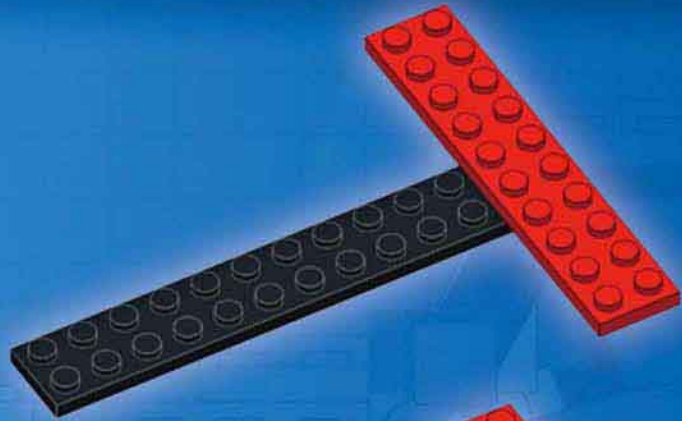

2

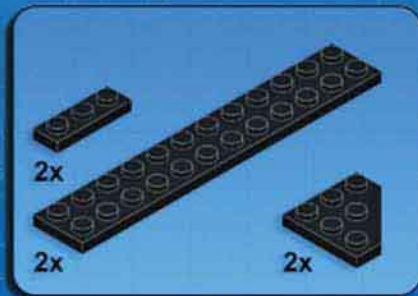
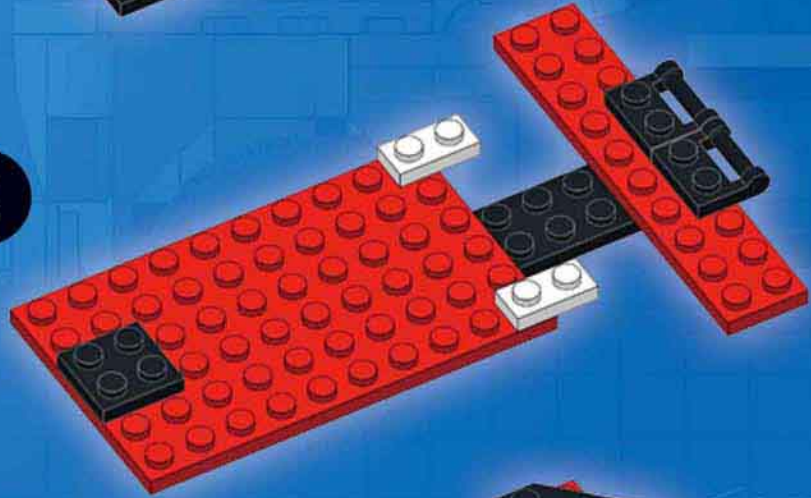

3

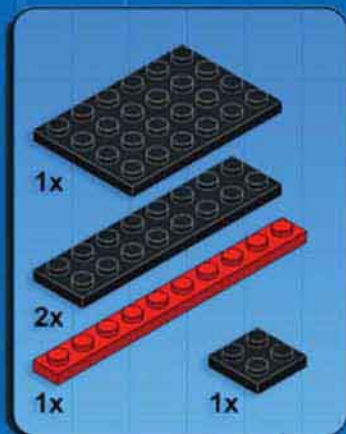
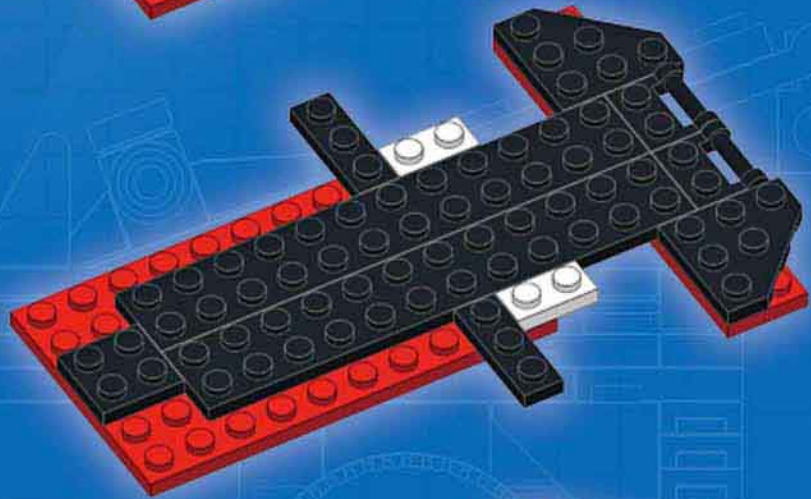

4

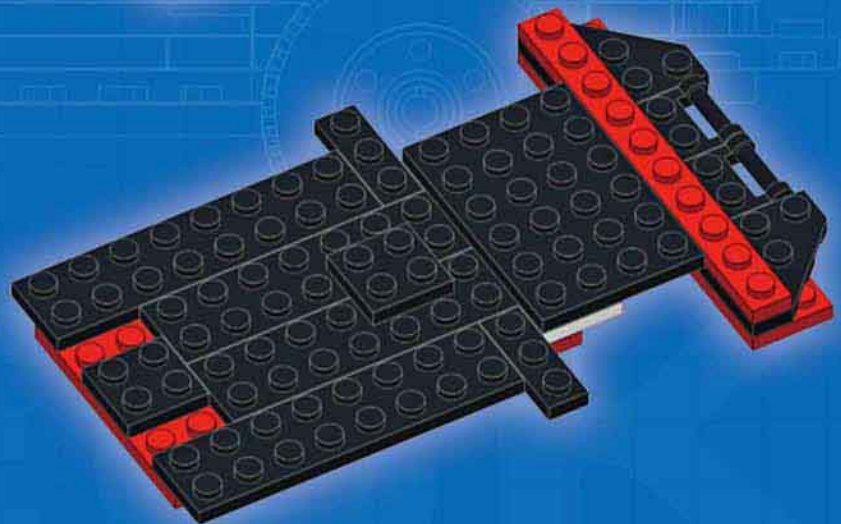



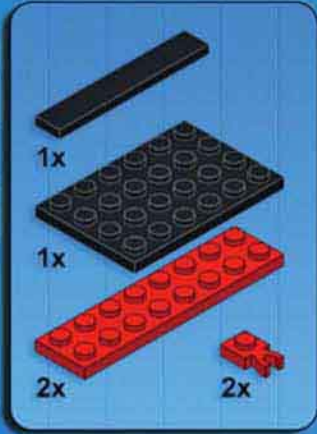

5

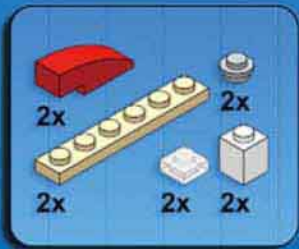
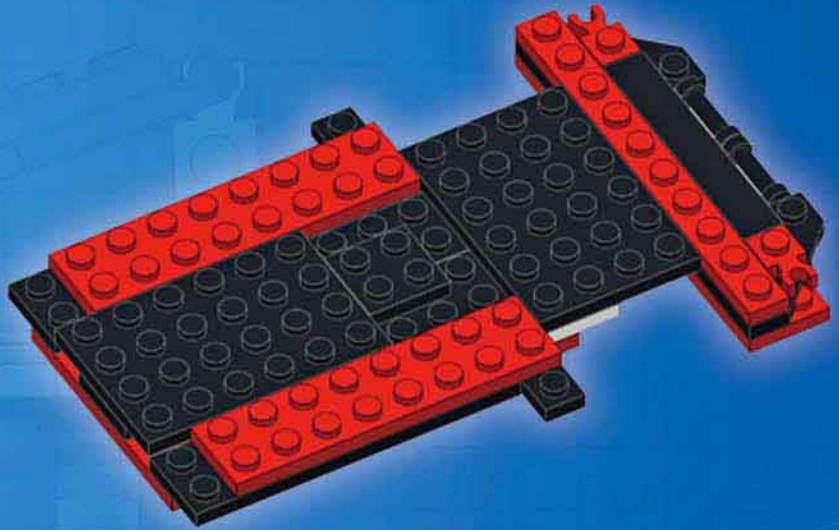

6

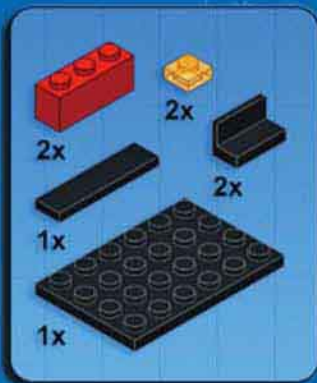
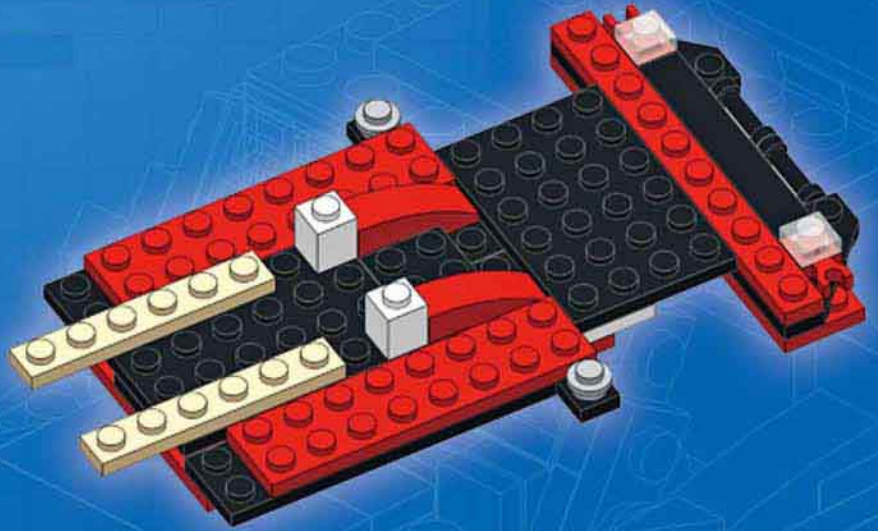

7

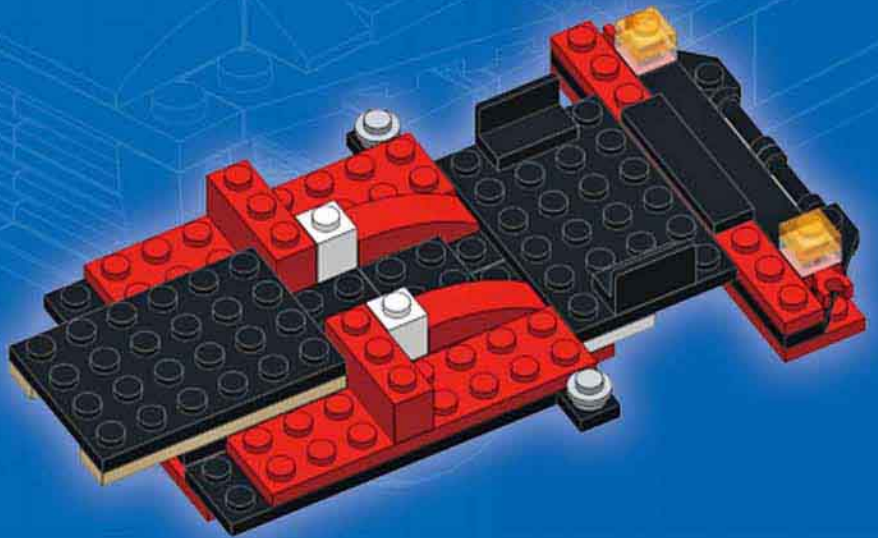

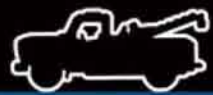

8

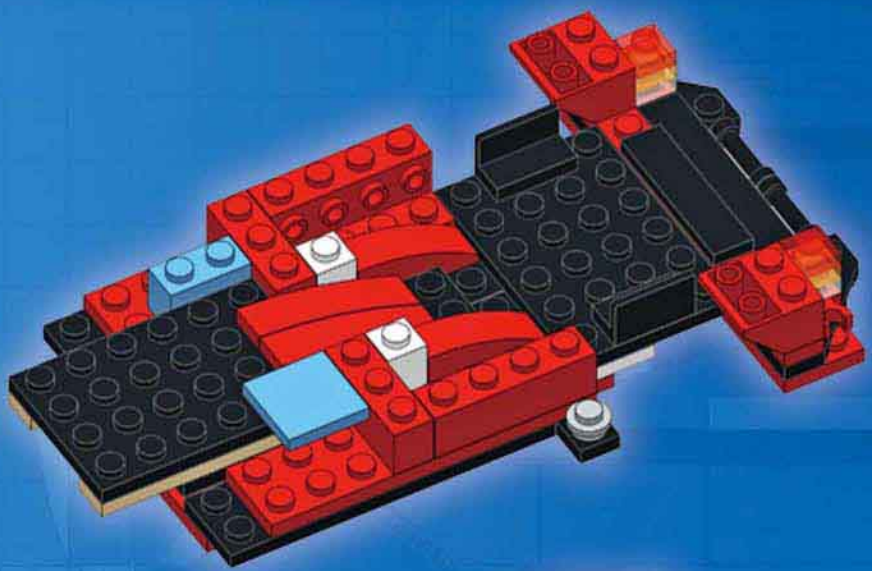
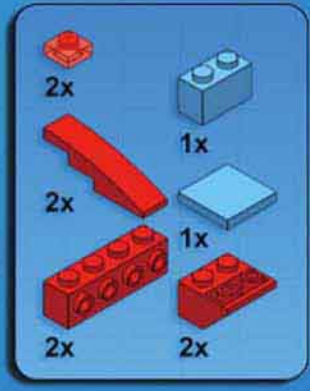

9

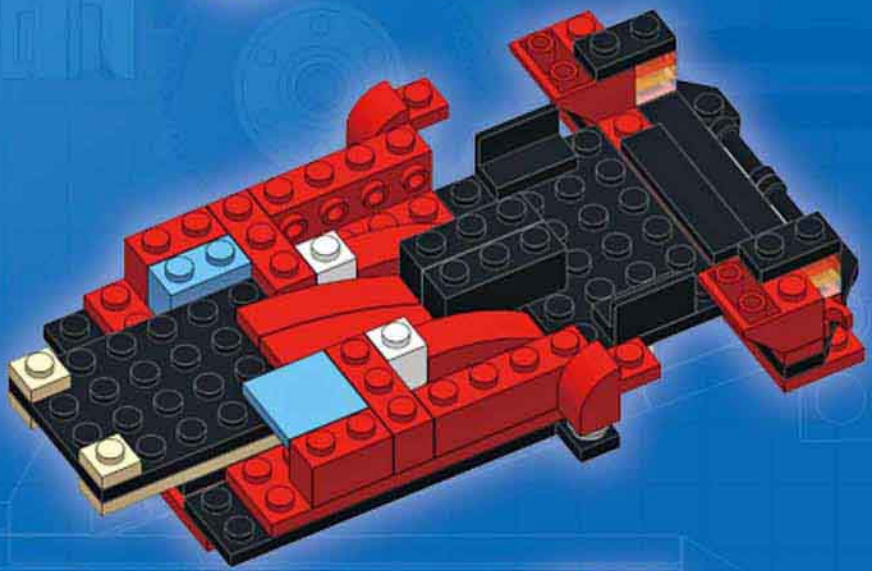
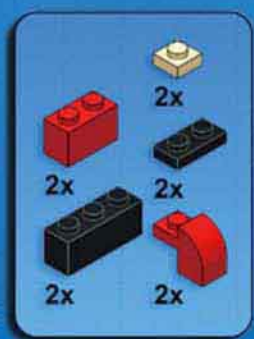

10

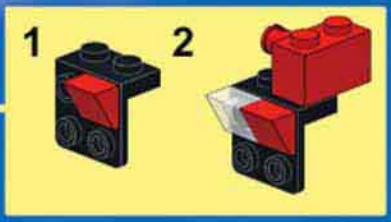
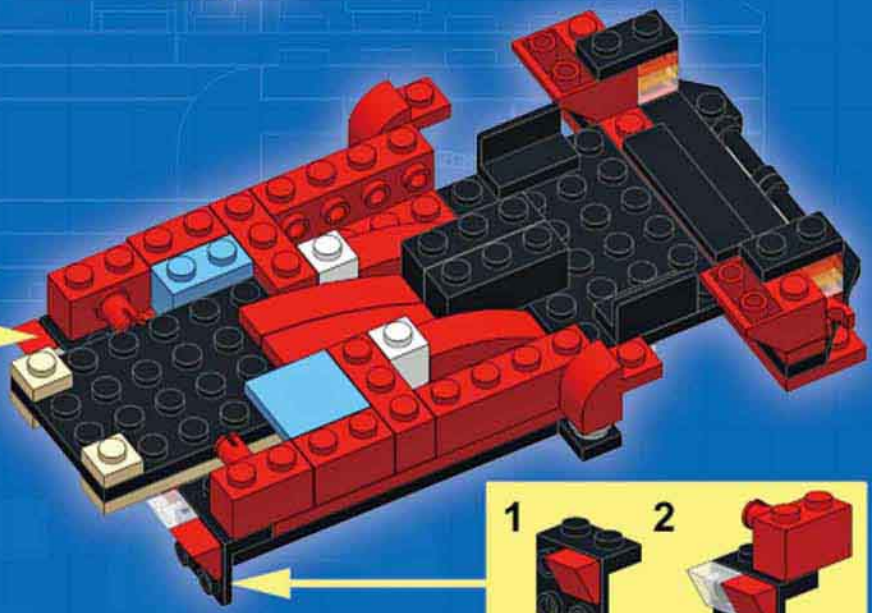
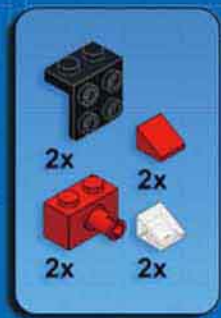



11

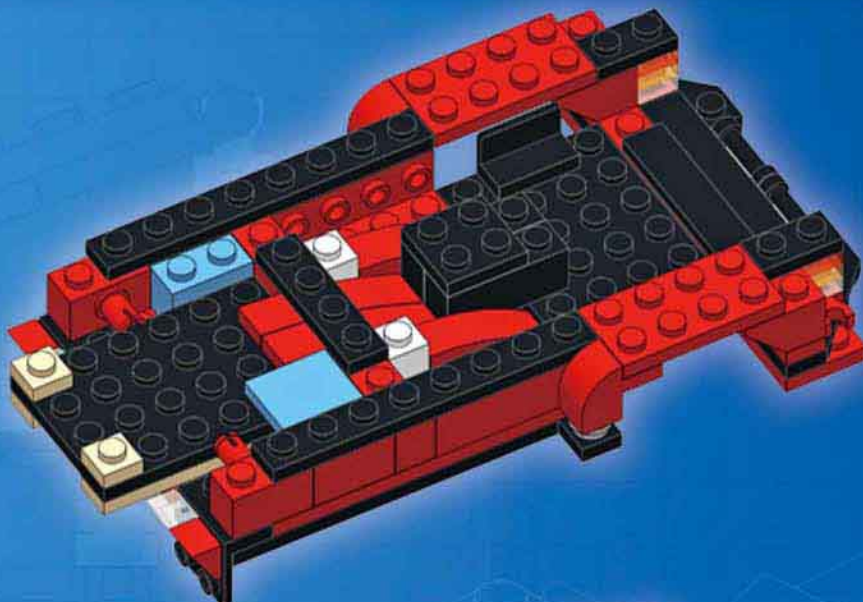
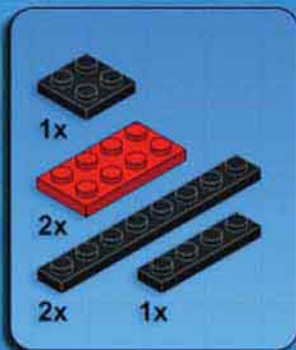

12

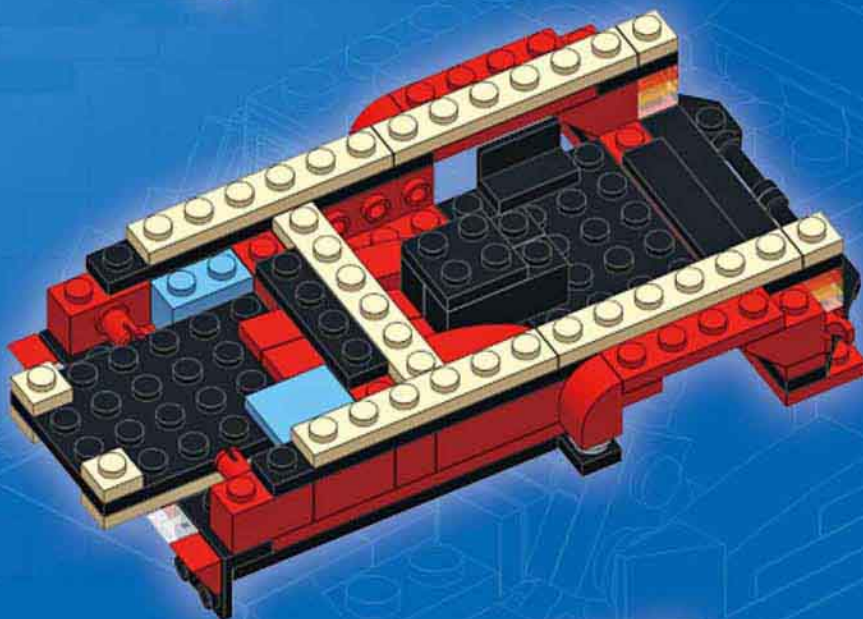
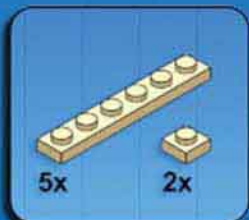

13

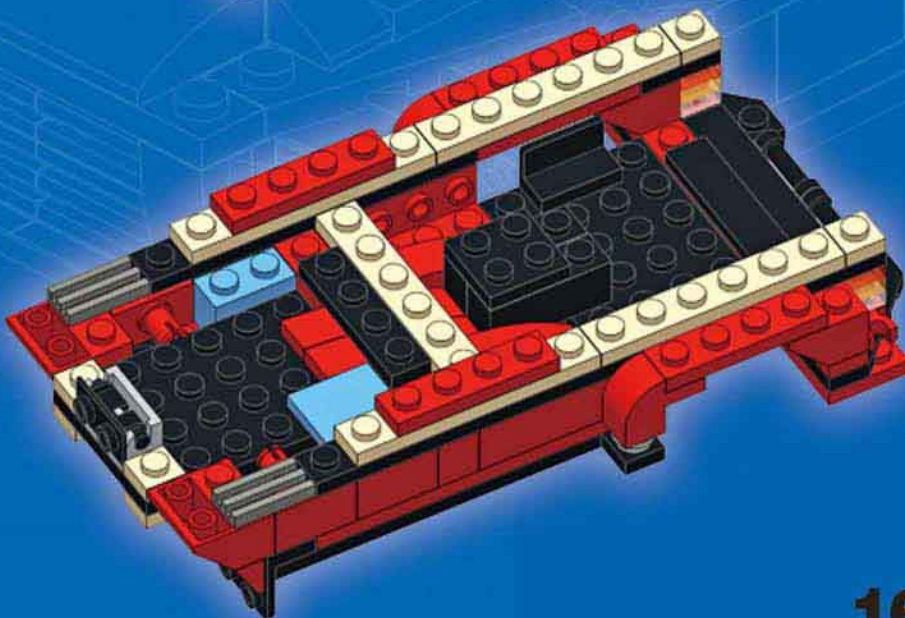
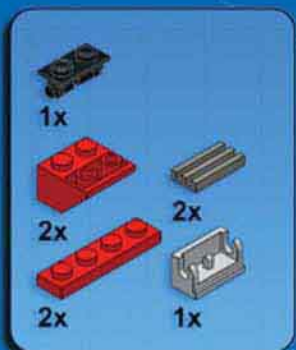

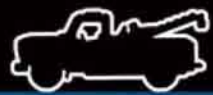

14

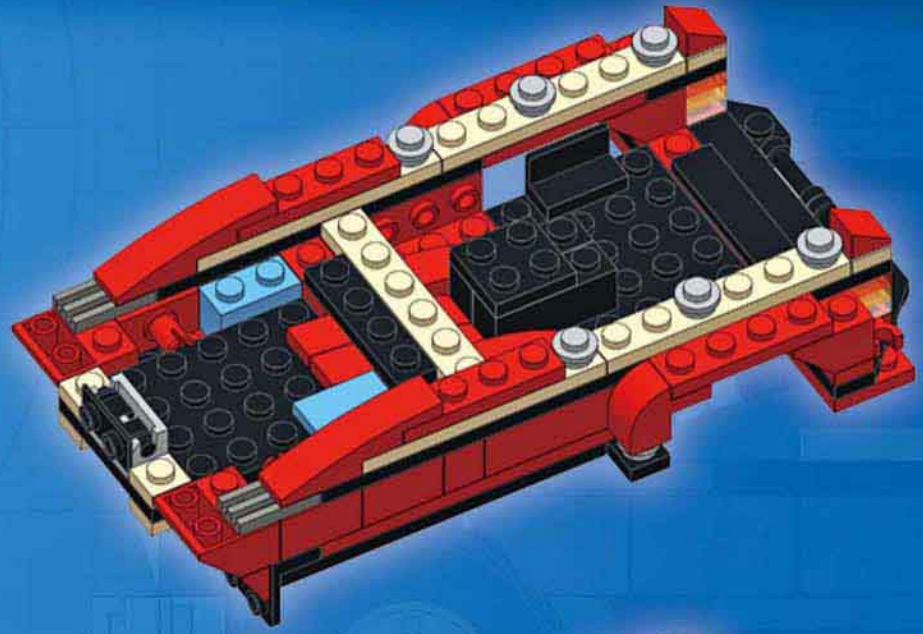
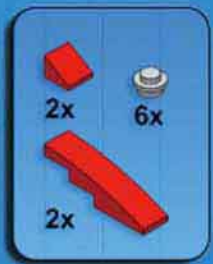

15

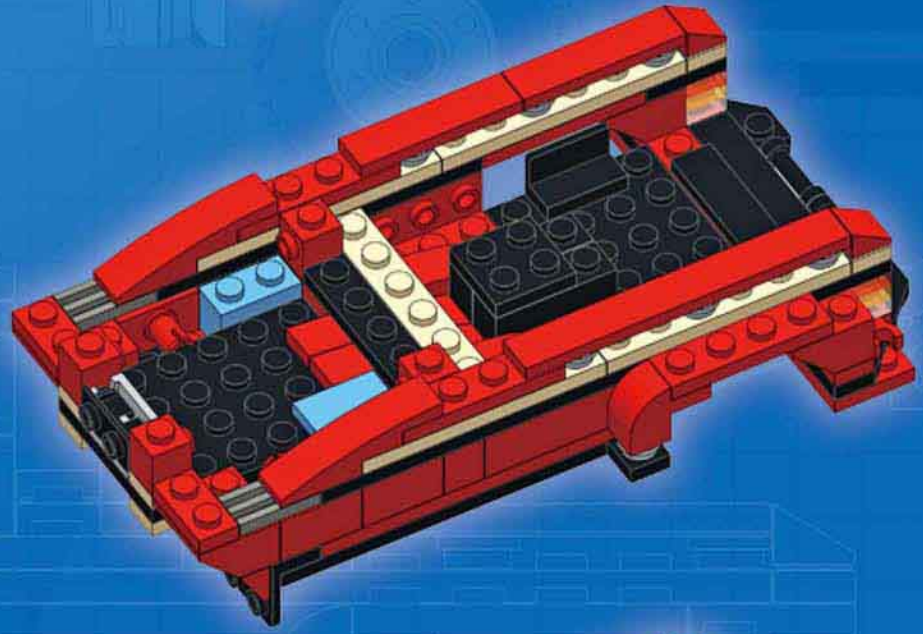
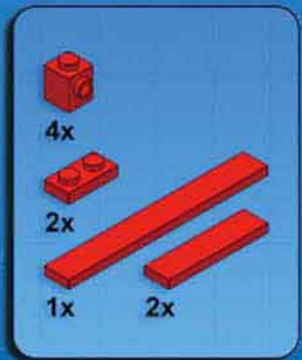

16

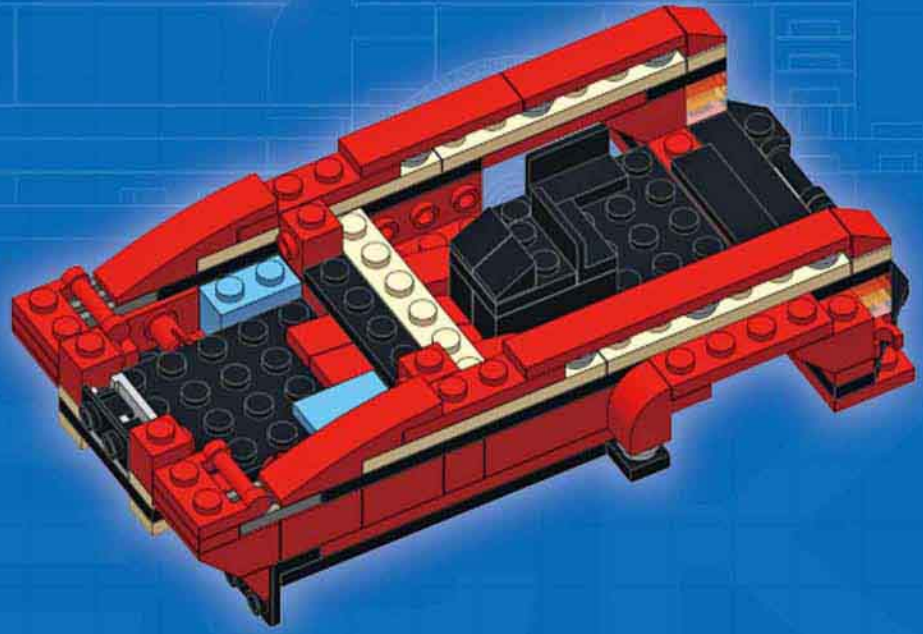



17

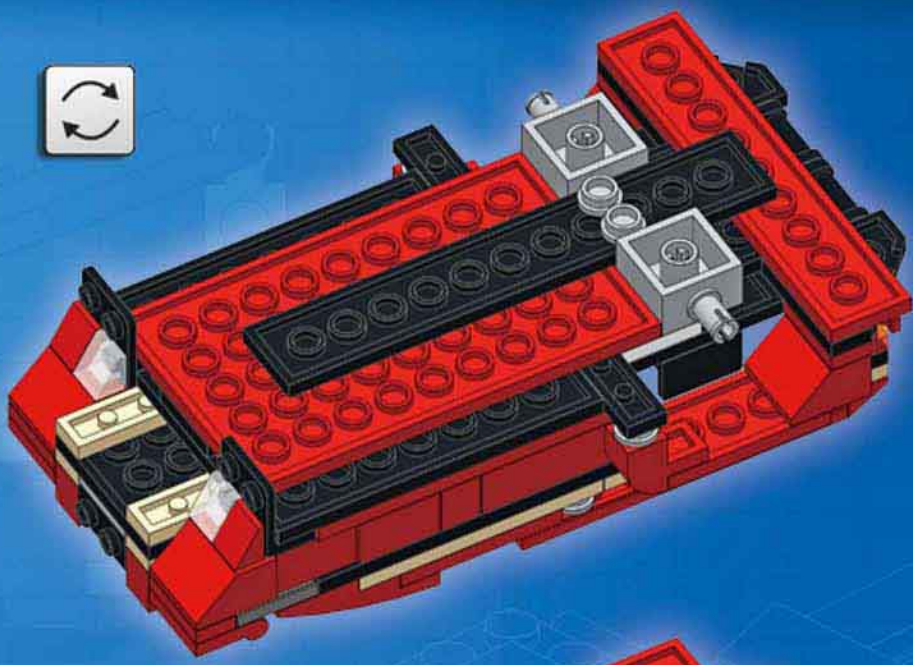
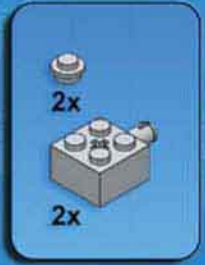

18

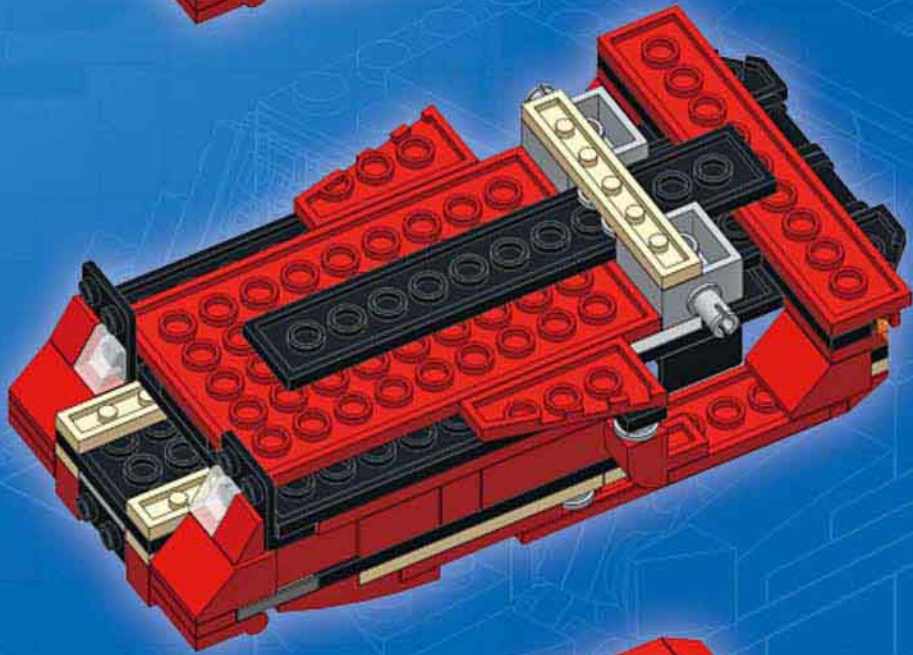
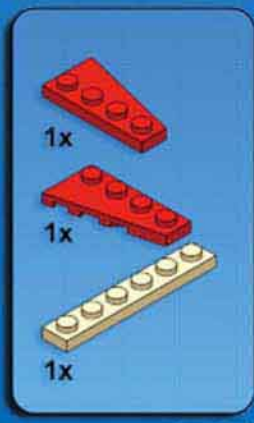

19

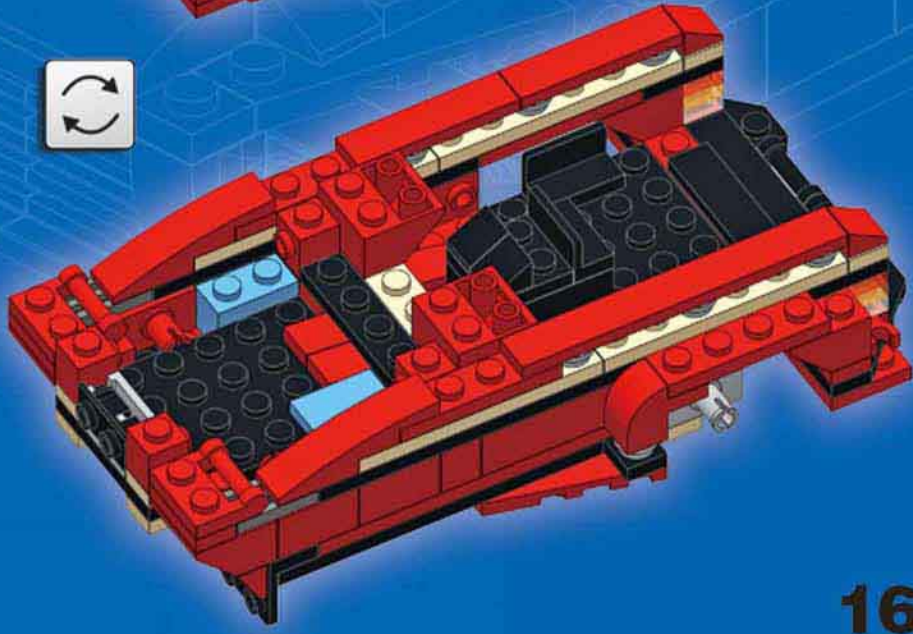

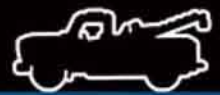

20



1

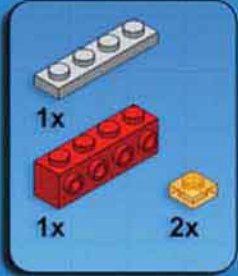

2

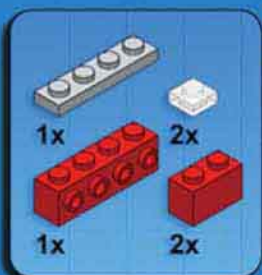
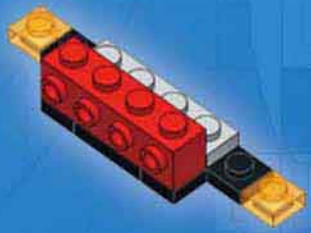

3

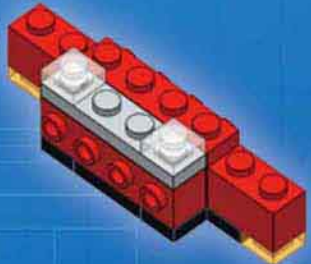

4

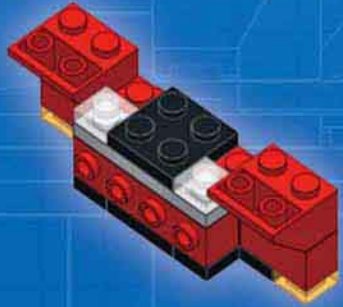

5

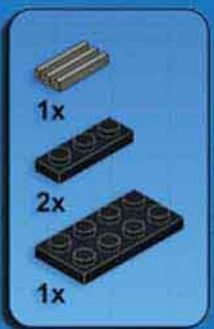
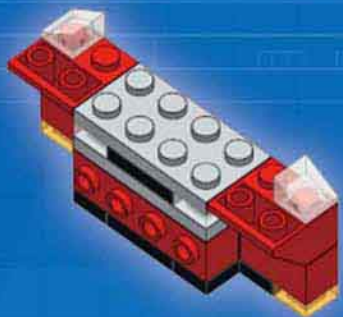

6

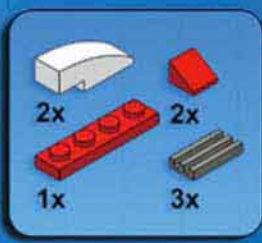
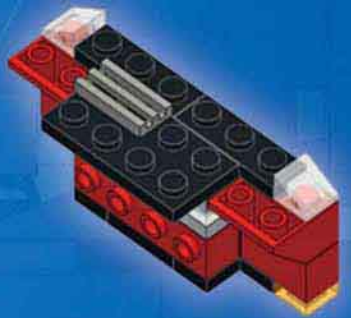

7

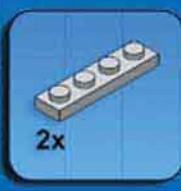
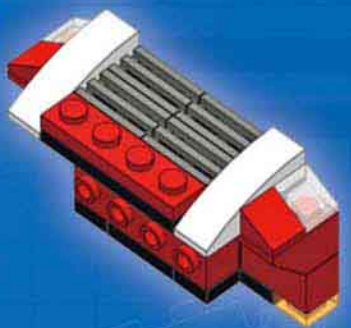

8

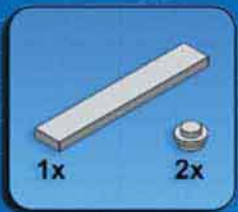
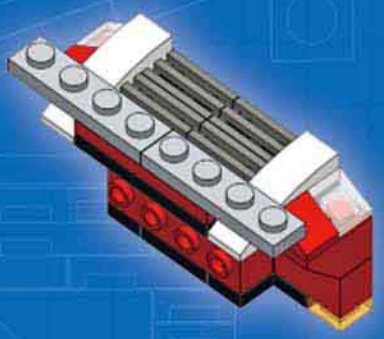

9

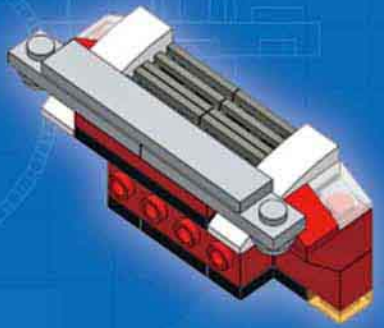

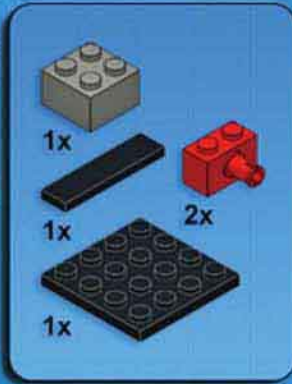

10

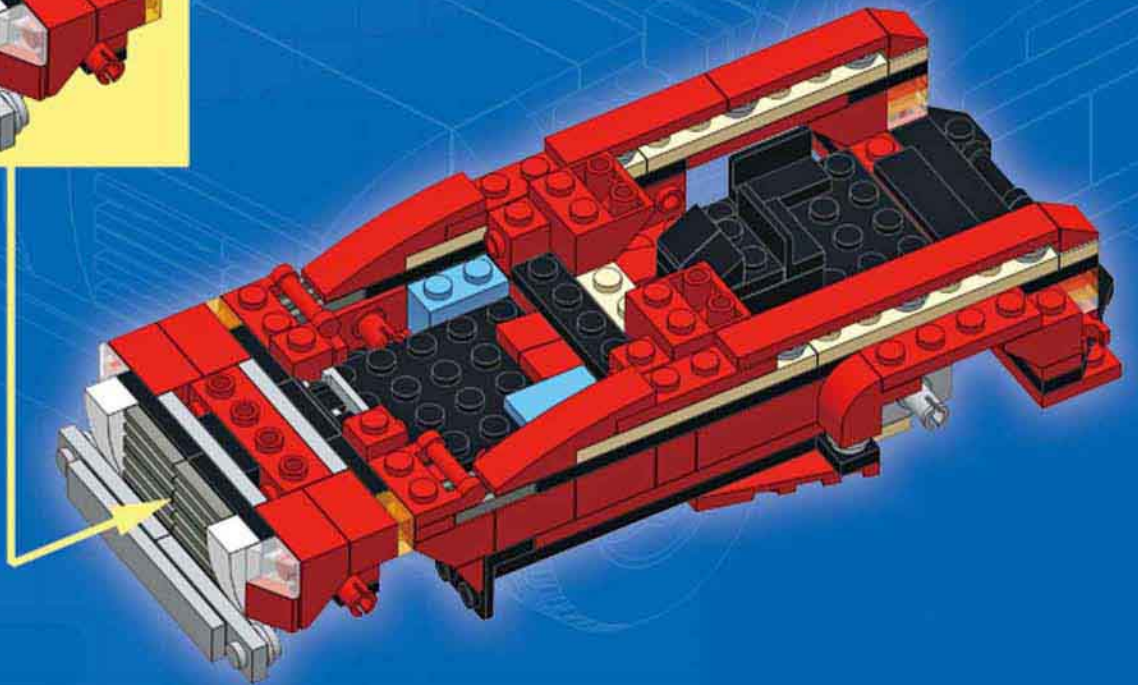
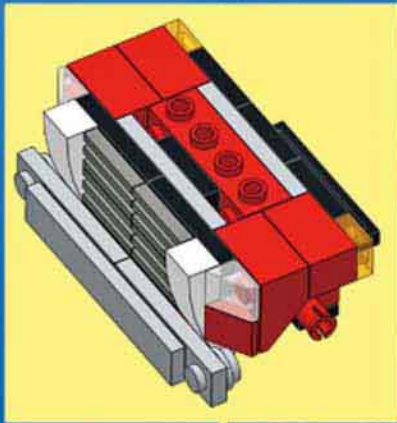
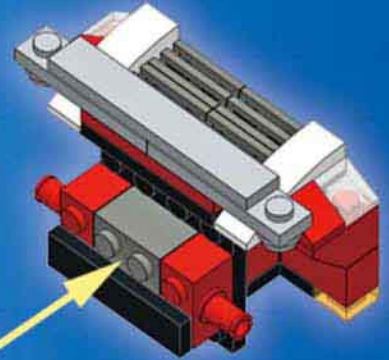
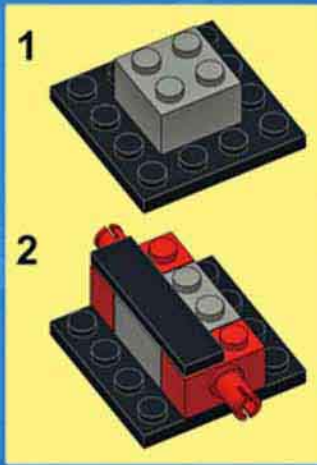

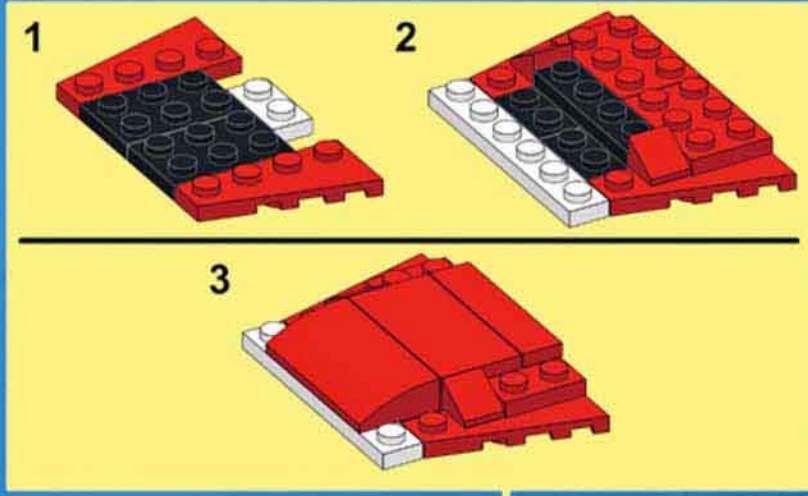
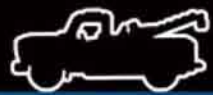

21

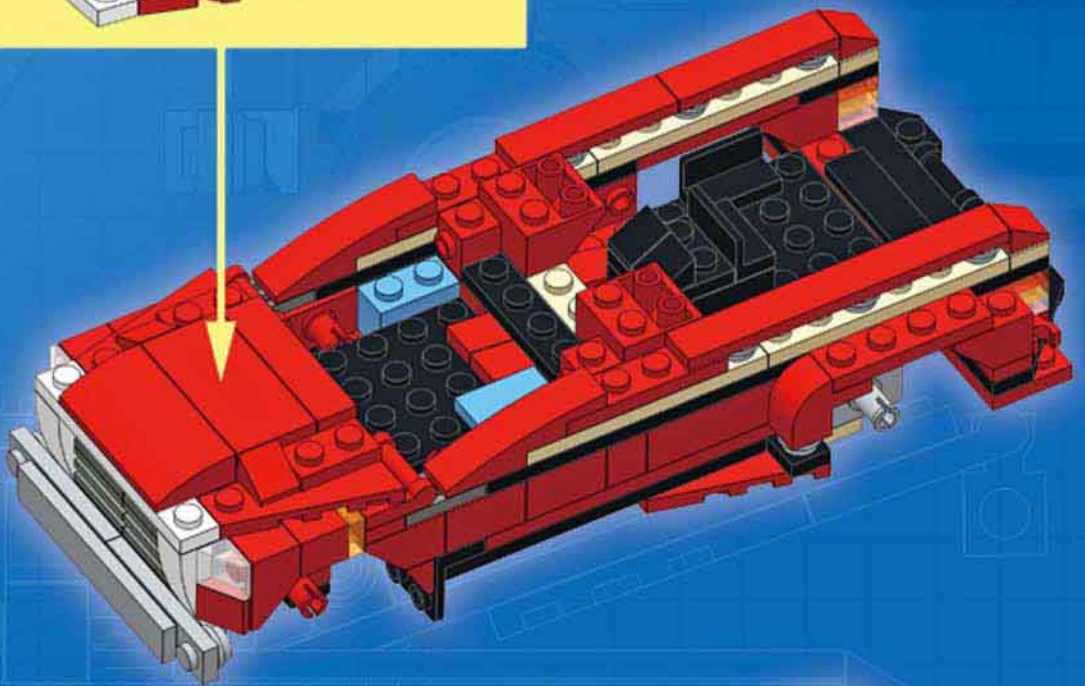
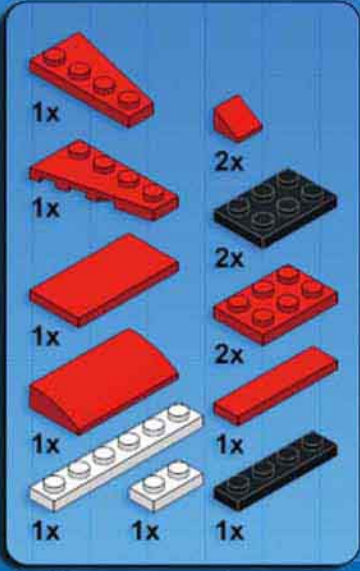

22

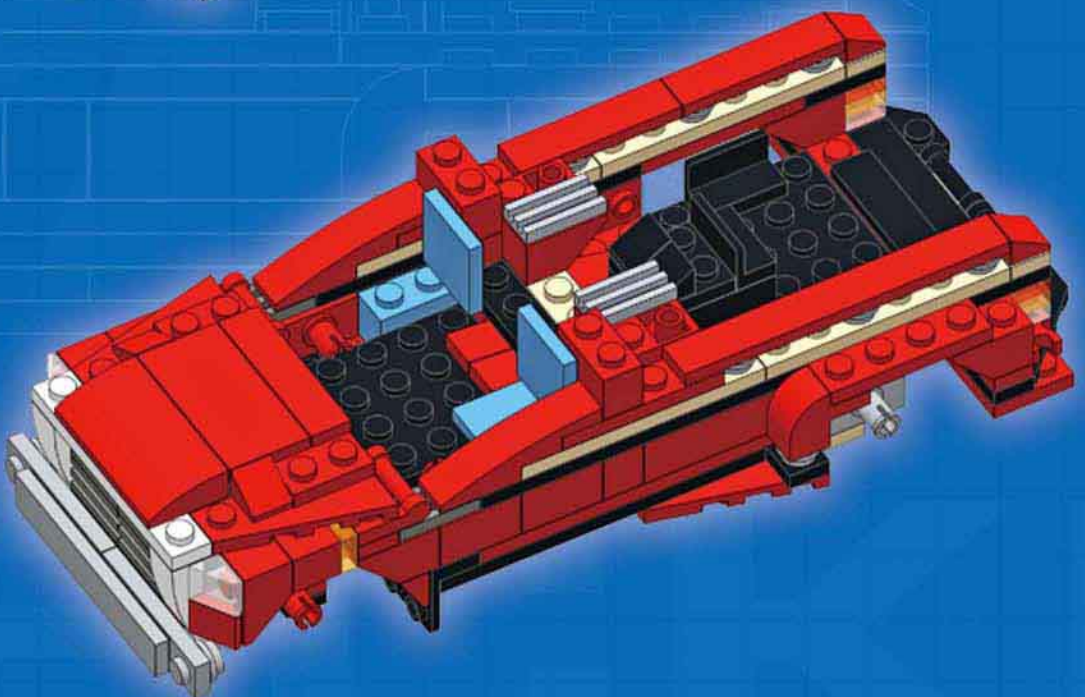
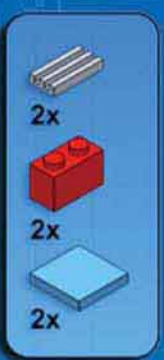



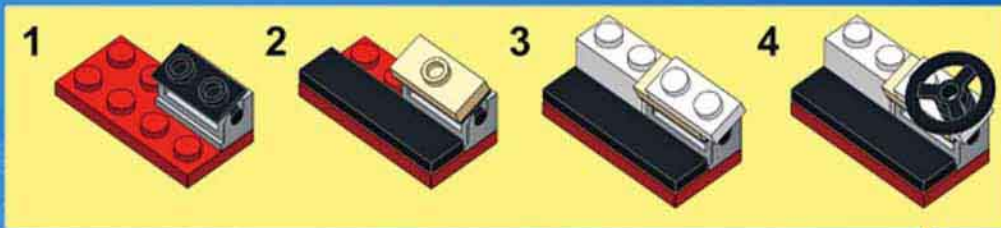

23

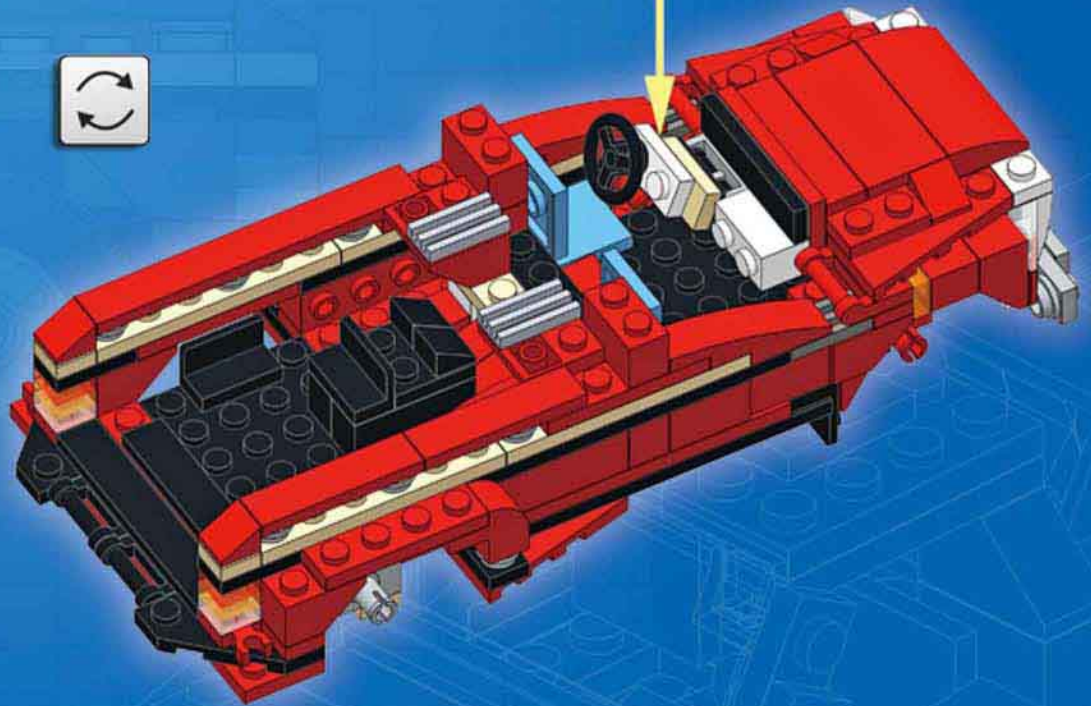
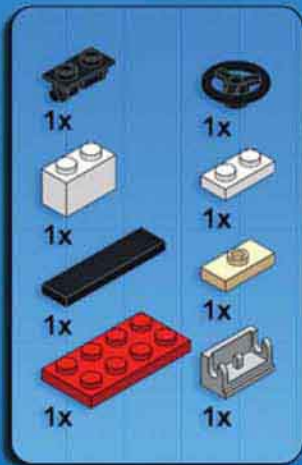

24

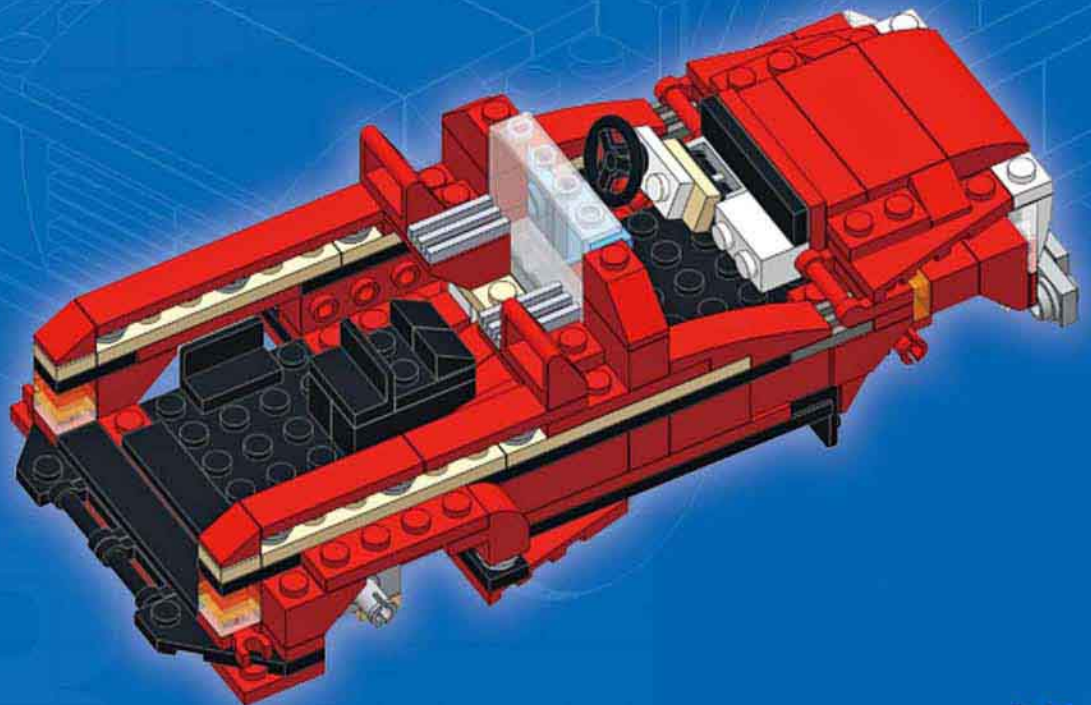
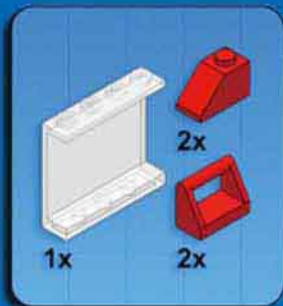

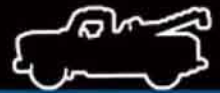

25

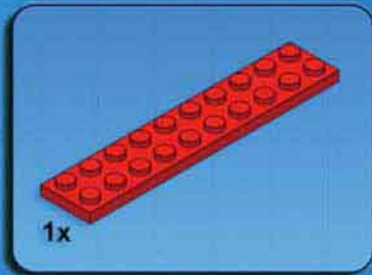

1

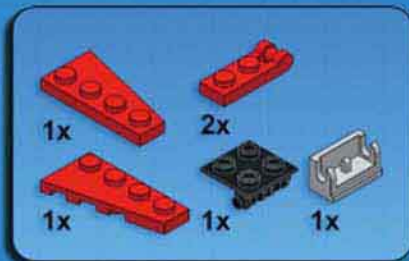
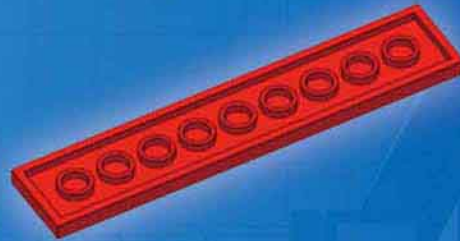

2

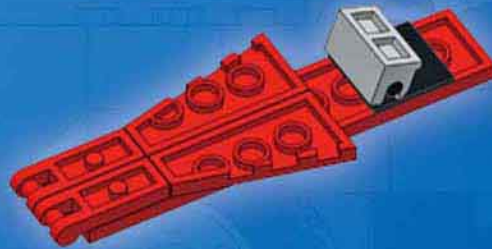

3

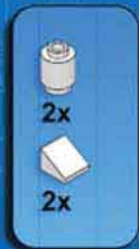
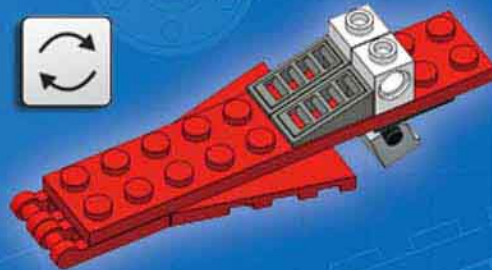

4

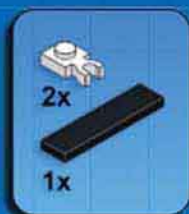
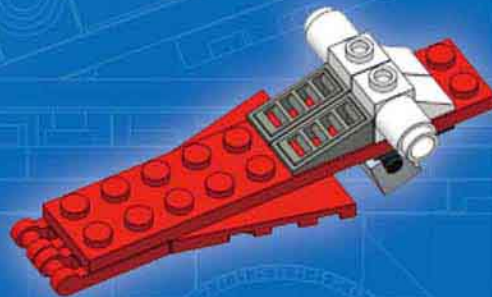

5

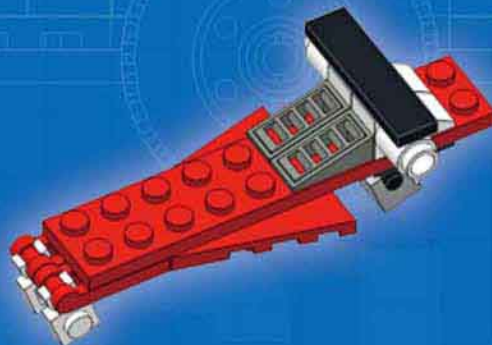

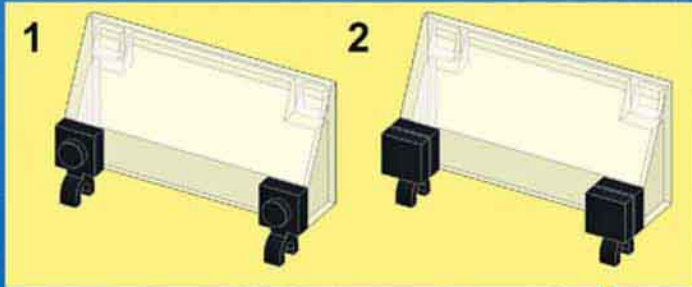
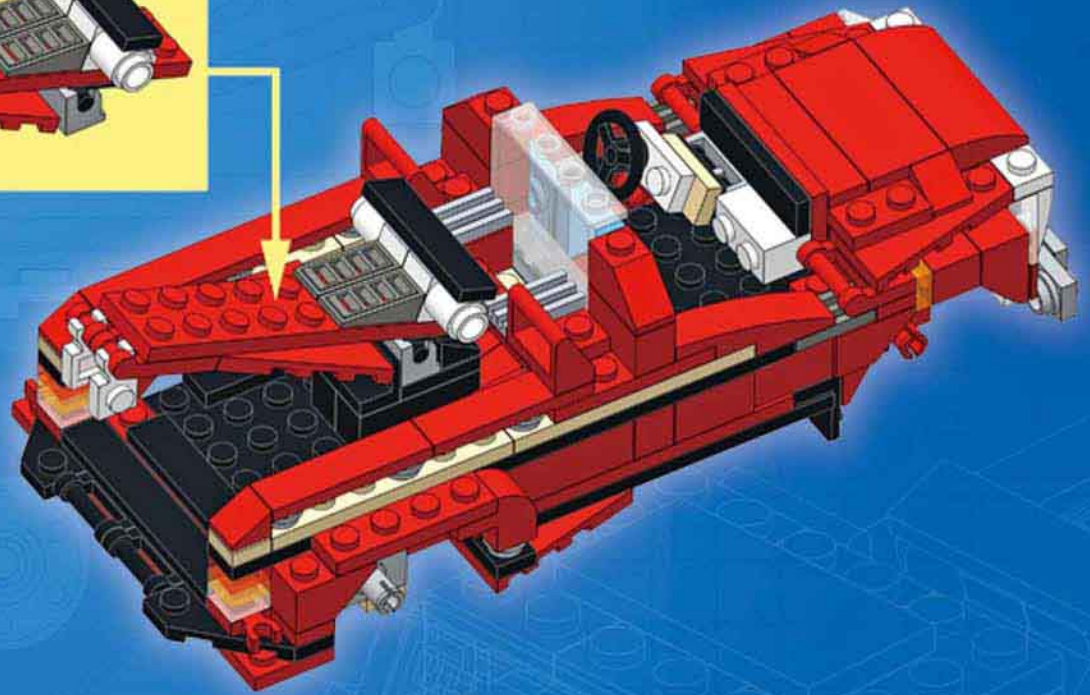
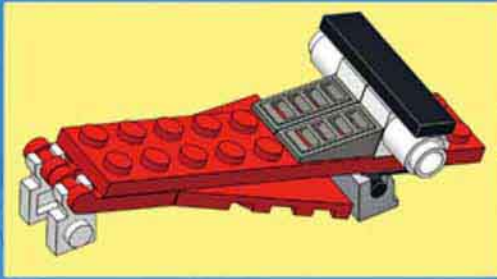

26

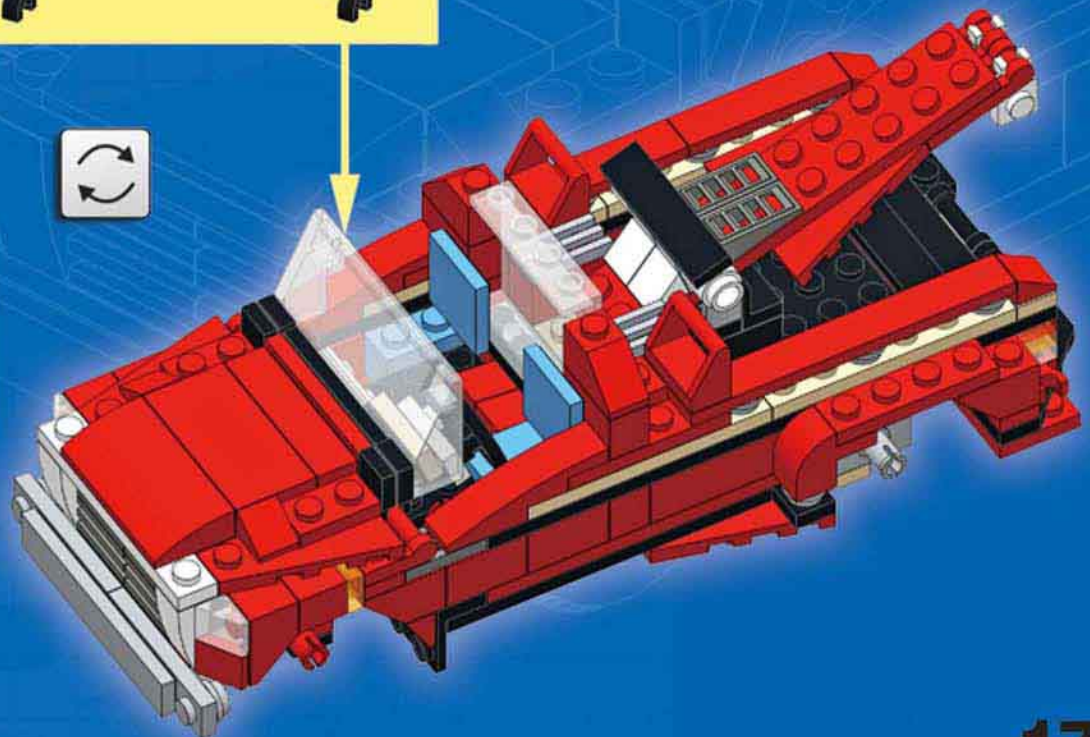
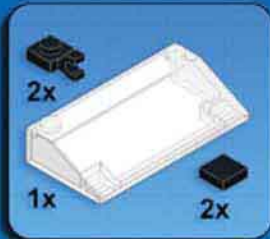

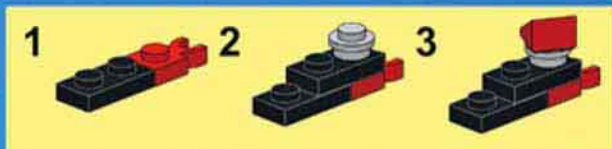



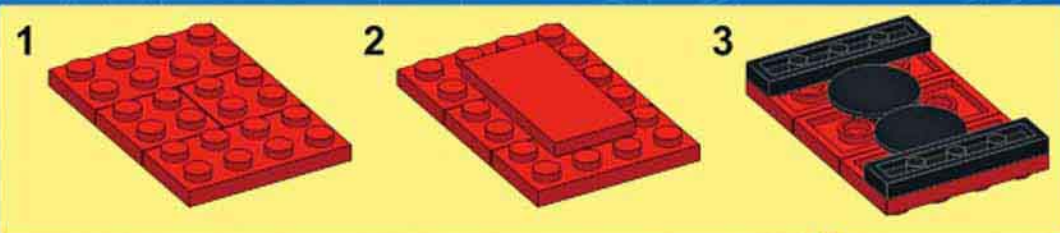
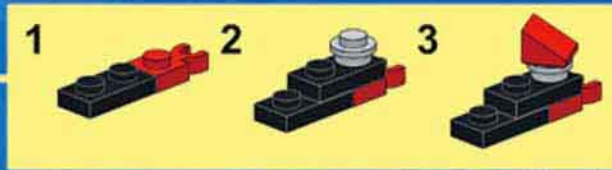
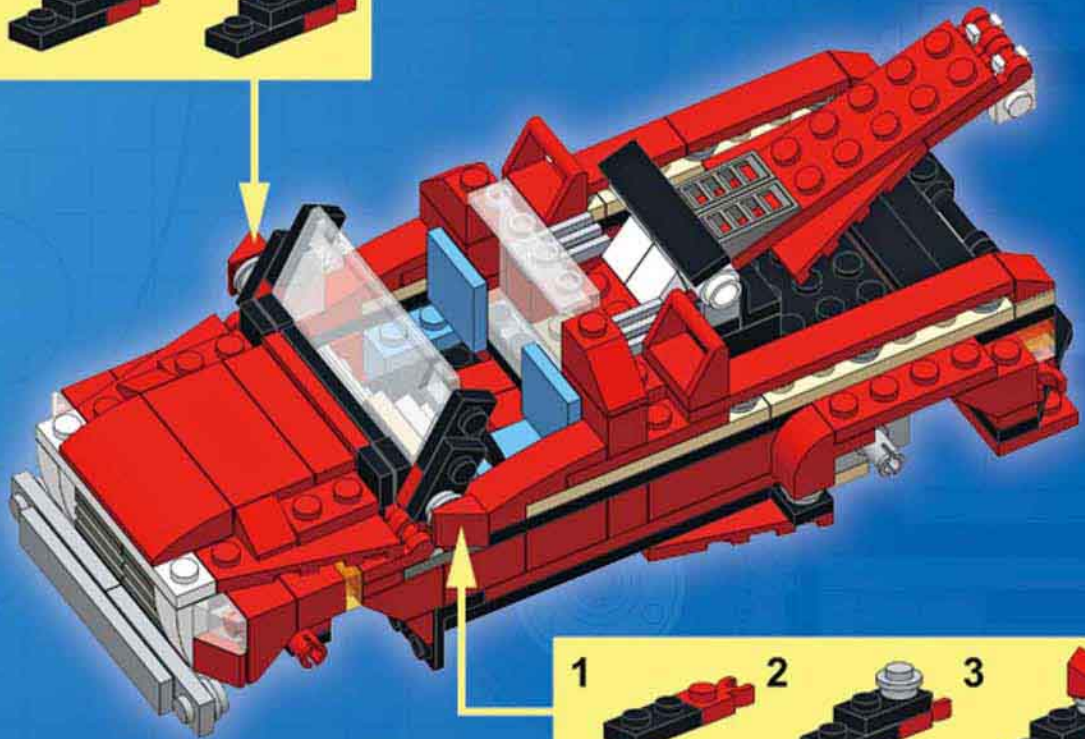

27

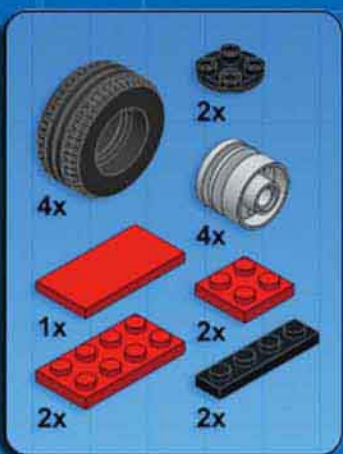

28





Complexity   
 Functions   
 Pieces 

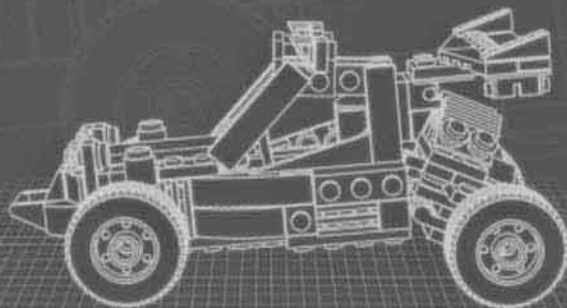
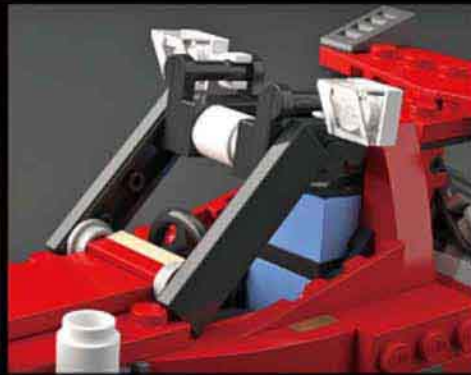

## DUNE BUGGY

Design notes: roll cage, rear V4 engine, bull bar, exposed shocks, big rear wing, spotlights

### Technical specifications:

Dimensions (l × w × h): 18 × 10 × 9 studs  
 Wheelbase: 12 studs  
 Axle width front/rear: 10/10 studs

Features: hinged rear axle

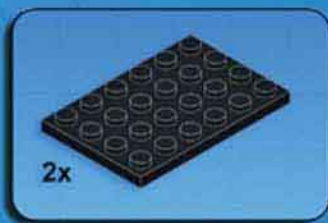

1

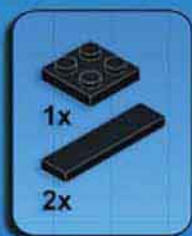

2

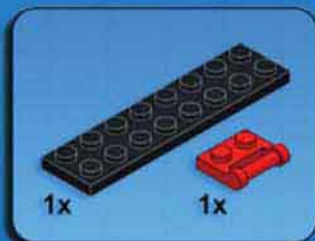
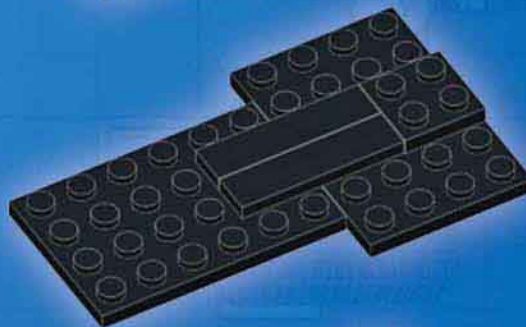

3

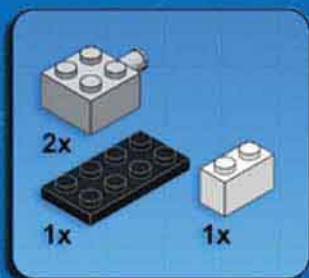

4

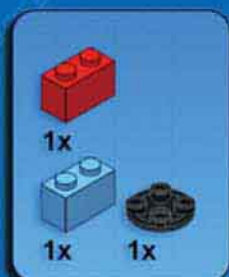
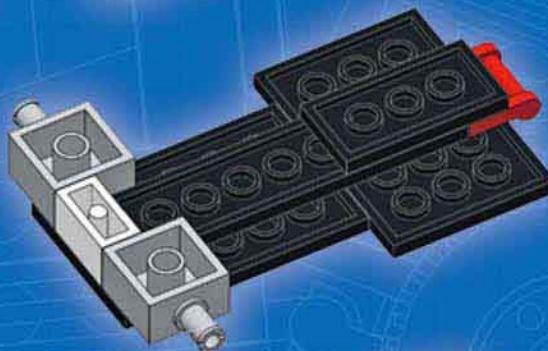

5

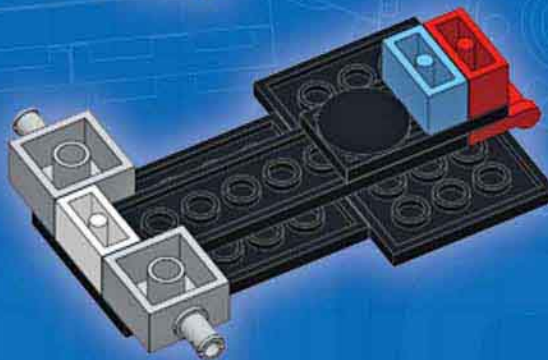



6

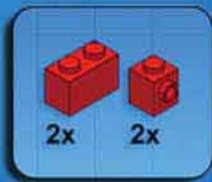
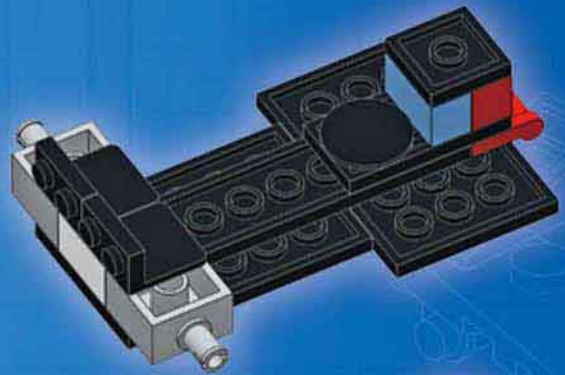

7

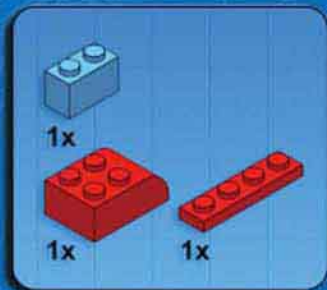
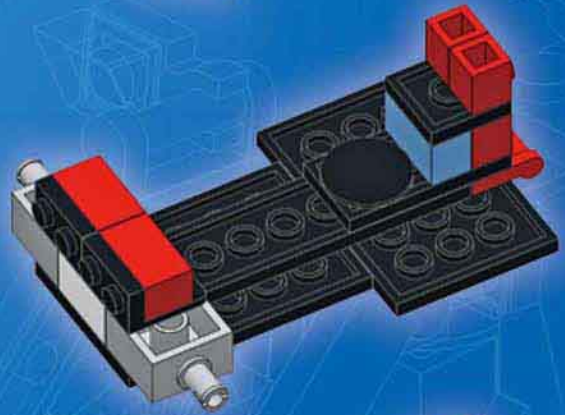

8

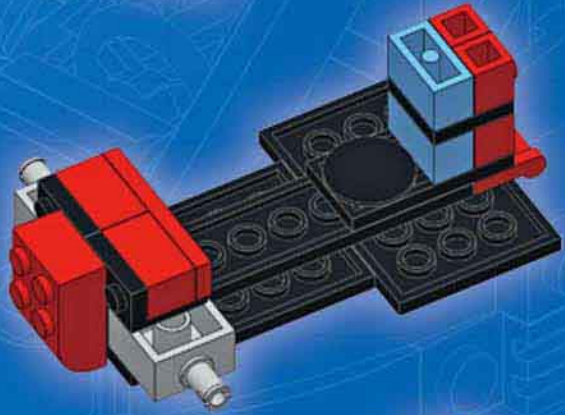

9

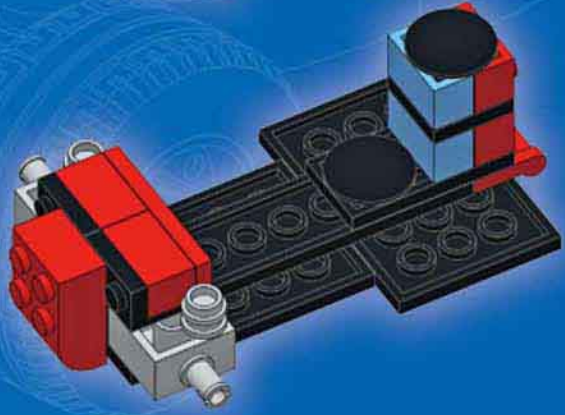



10



1

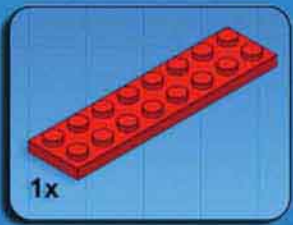

2

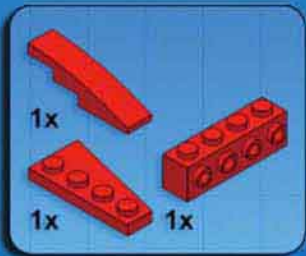
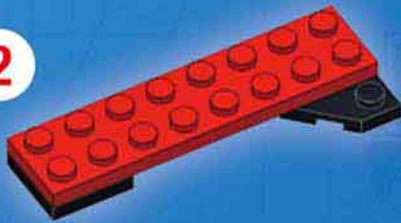

3

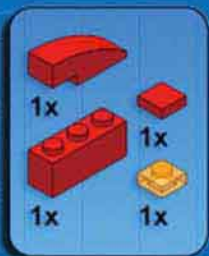
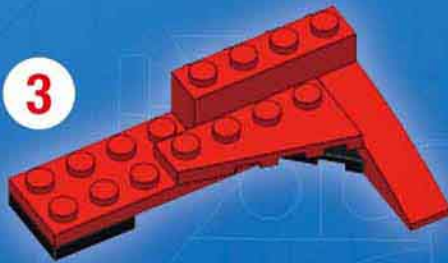

4

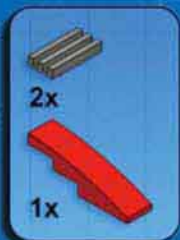
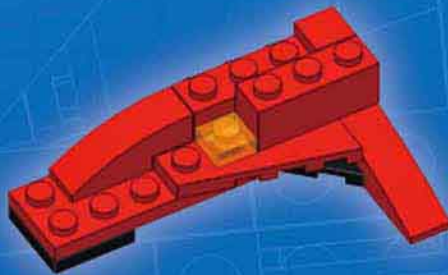

5

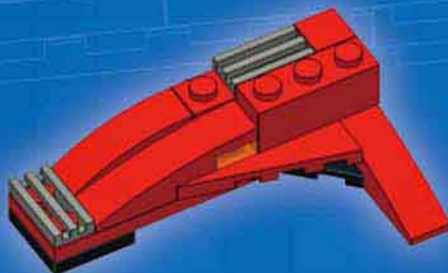

6

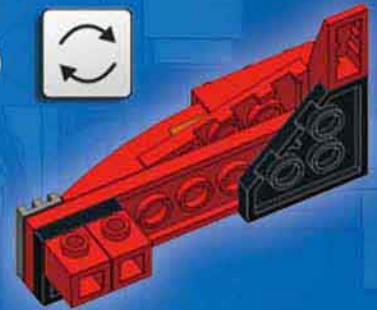

7



8

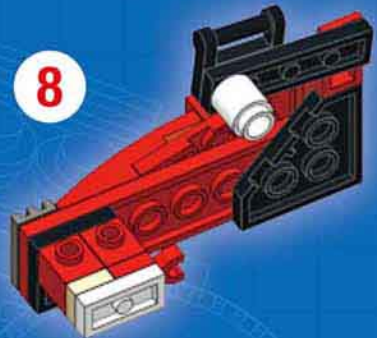

9





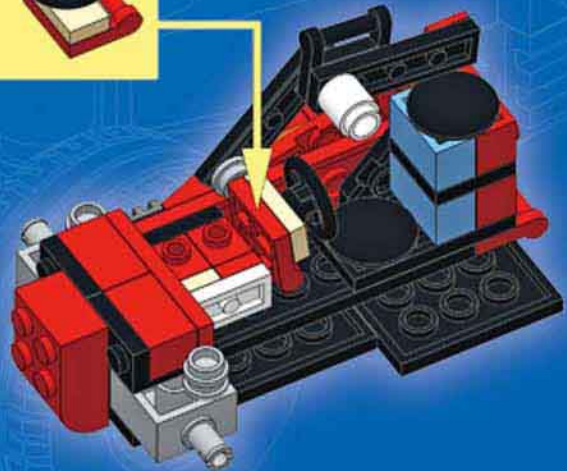
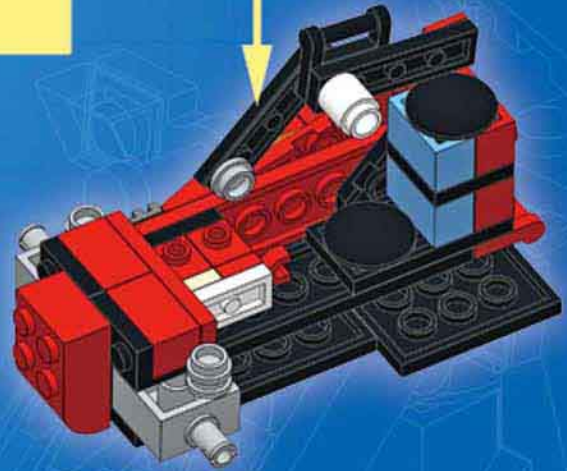
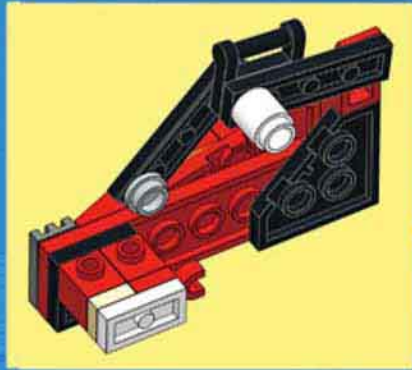

11

-  1x
-  1x
-  1x



12



1

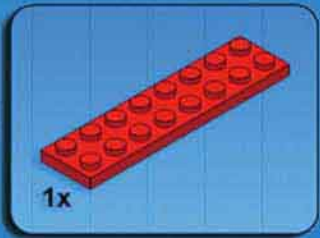

2

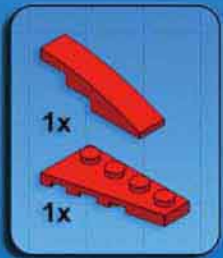

3

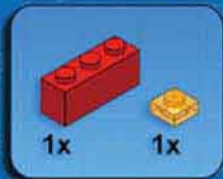
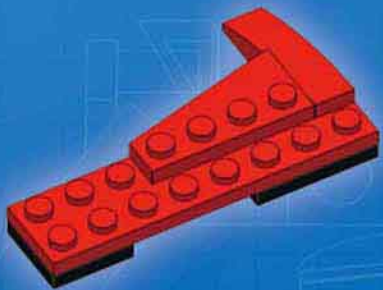

4

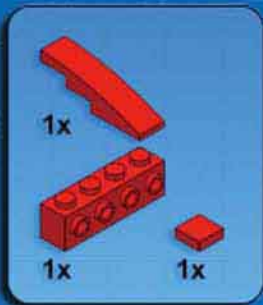
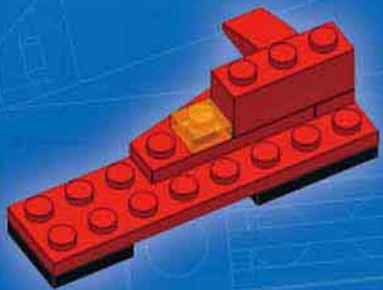

5

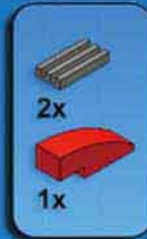
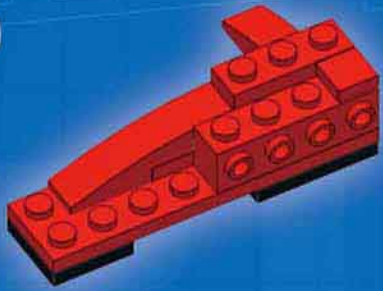

6

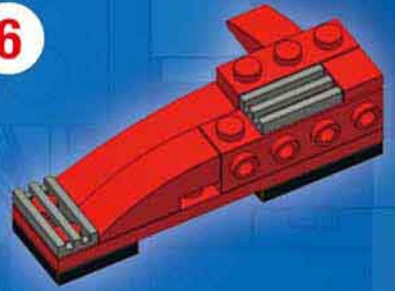

7



8



9



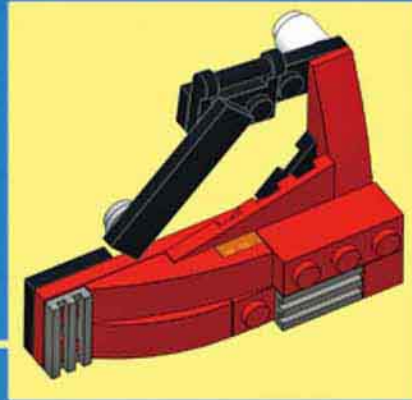
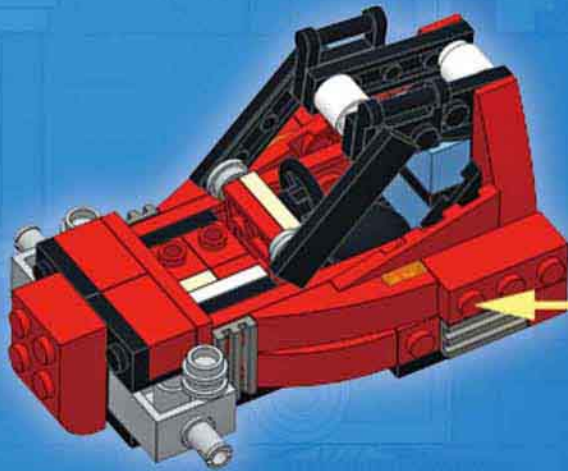

13

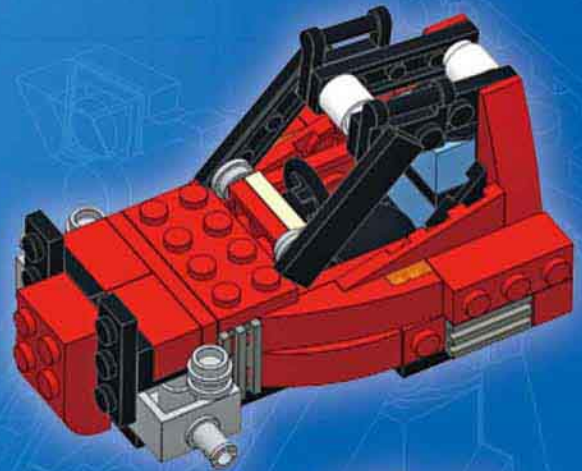
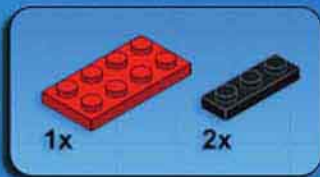

14

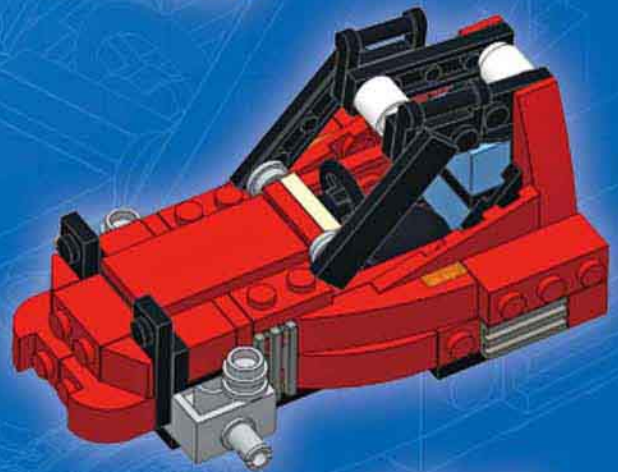
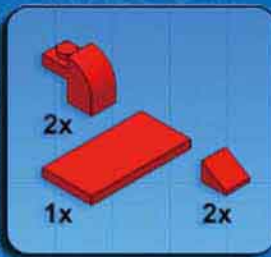

15

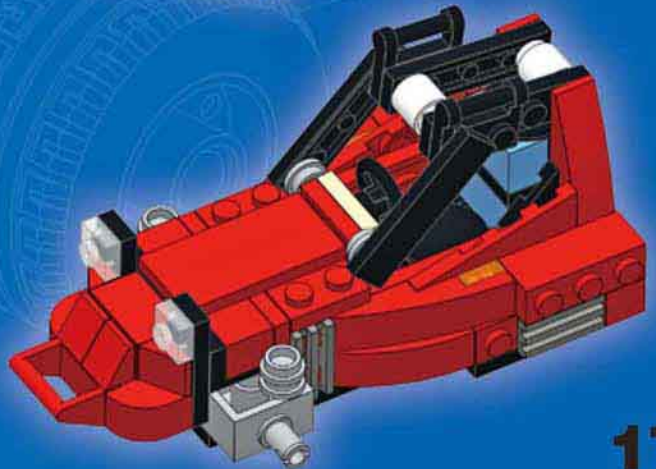
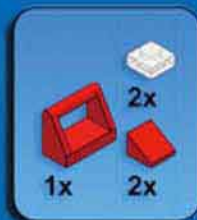



16

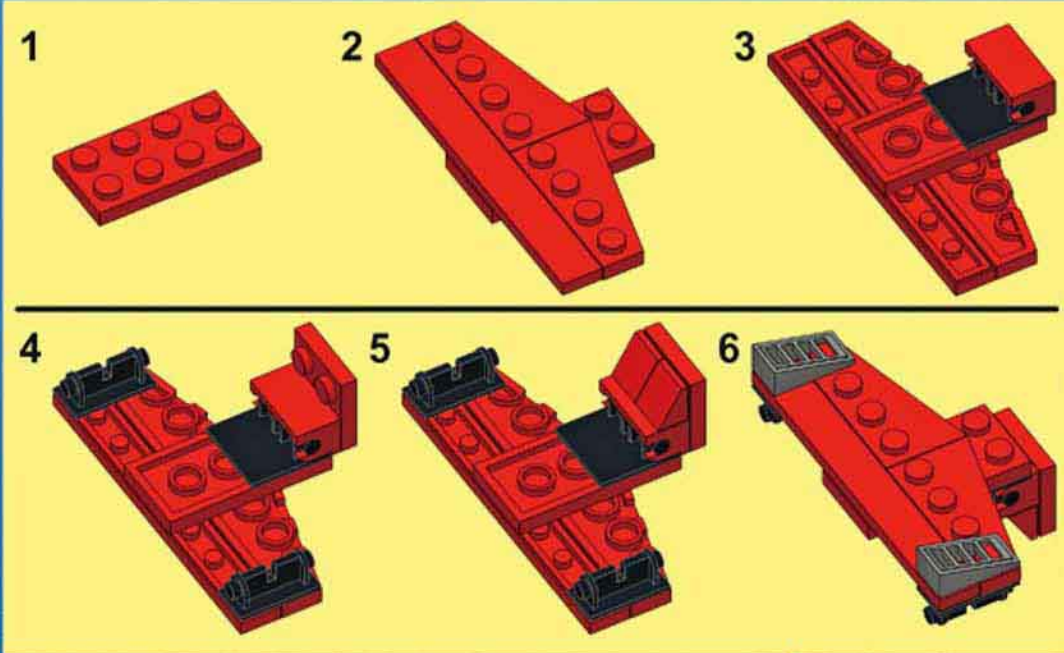
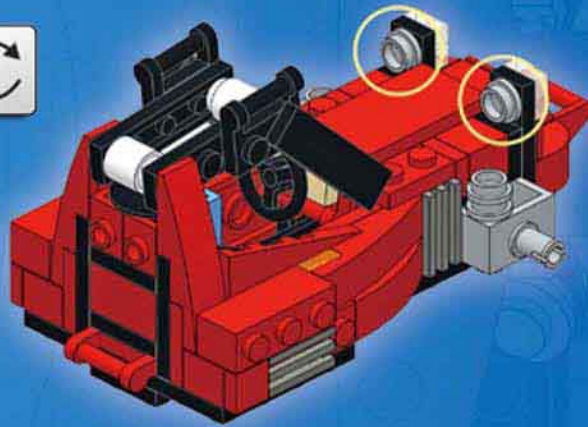

17

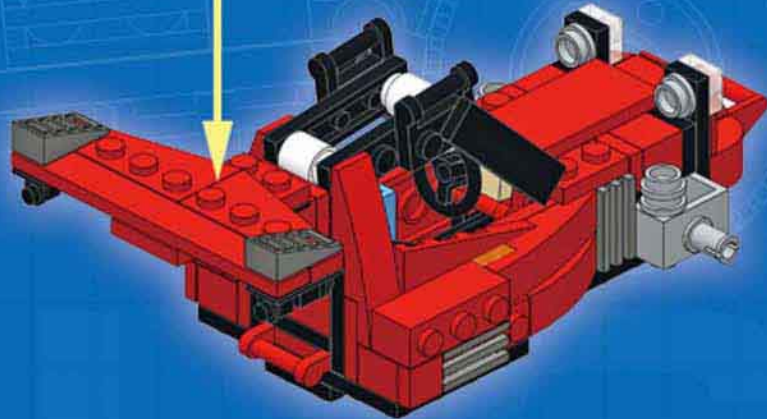
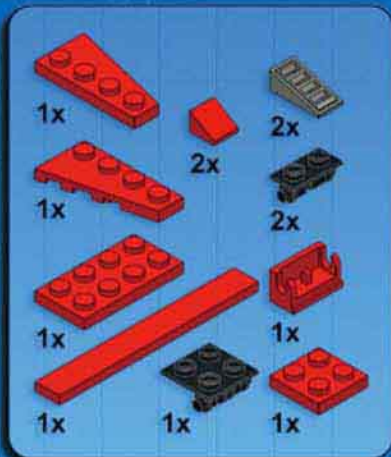



18

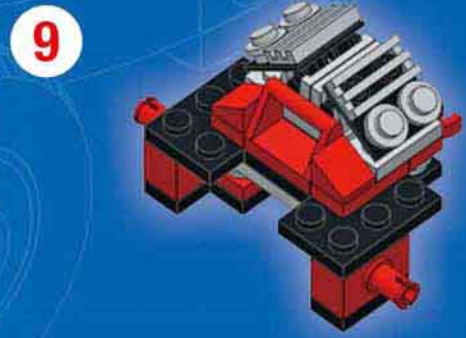
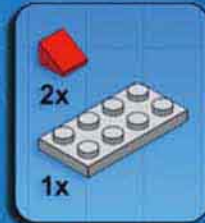
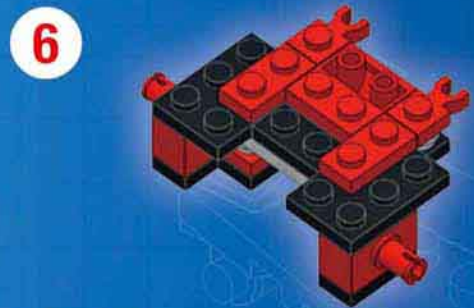
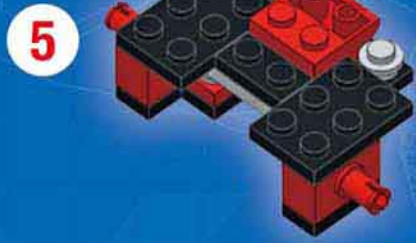
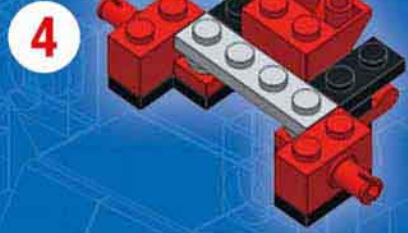
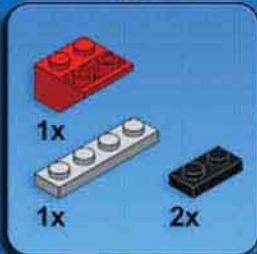
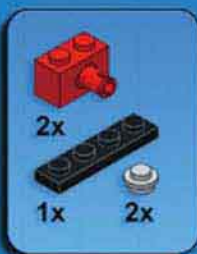



19

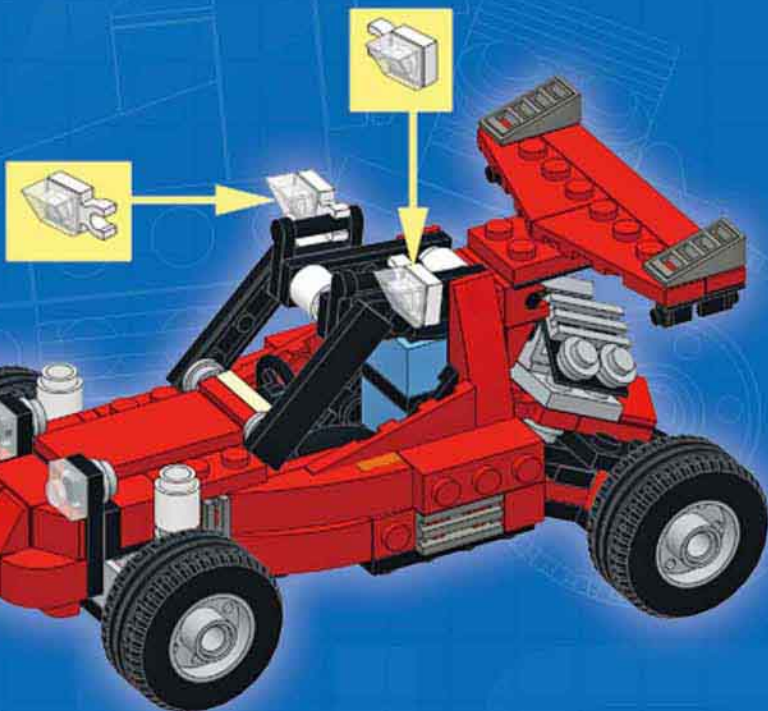



Complexity   
 Functions   
 Pieces 

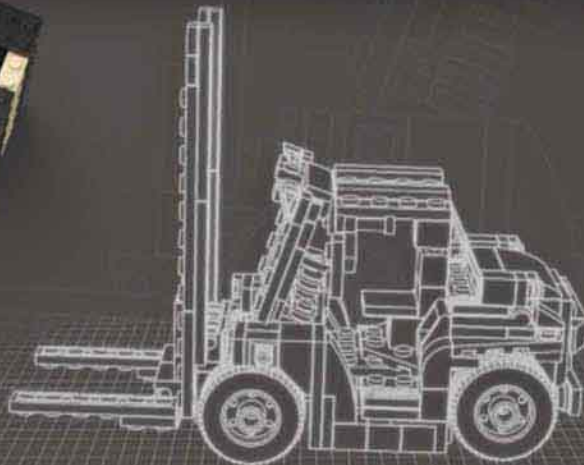
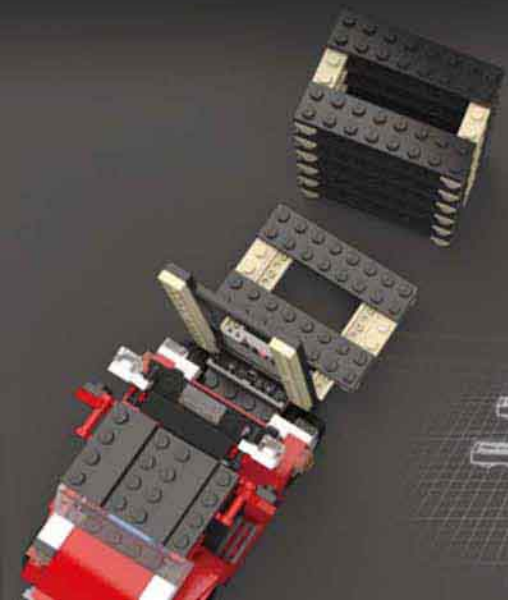

## FORKLIFT

Design notes: short wheelbase, open cabin, big mirrors, spotlights

Technical specifications:

Dimensions (l × w × h): 22 × 10 × 16 studs

Wheelbase: 9 studs

Axle width front/rear: 8/8 studs

Features: tilting mast, folding fork, pallet



1

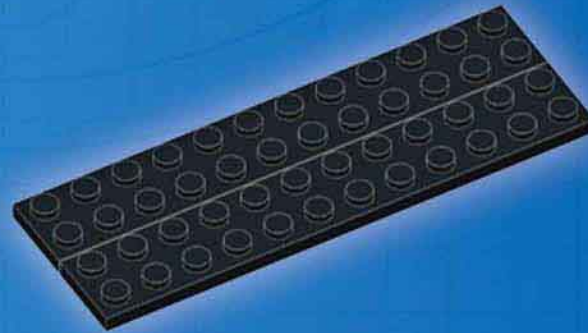
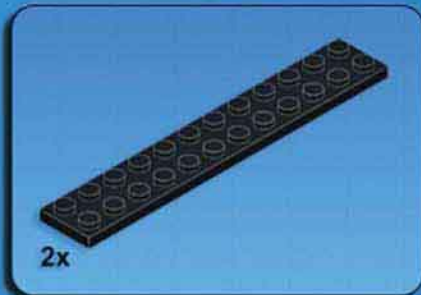

2

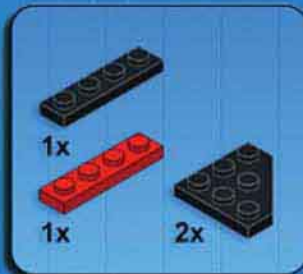

3

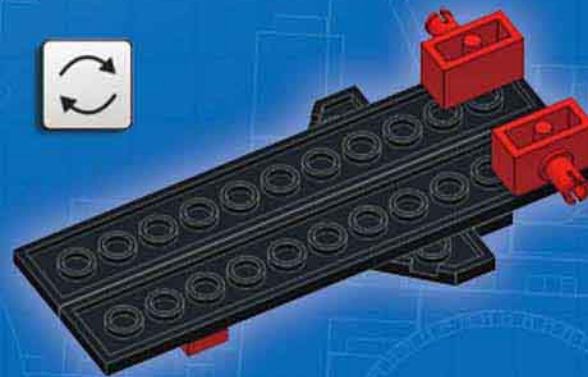

4

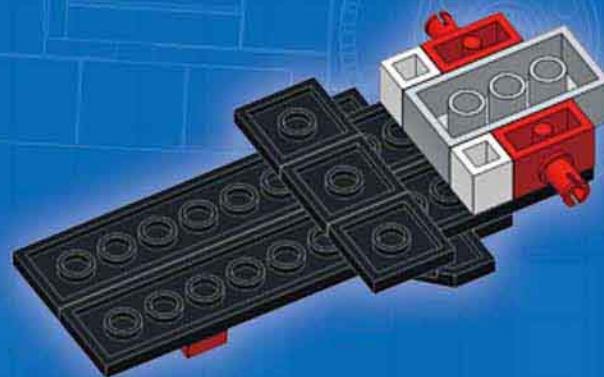
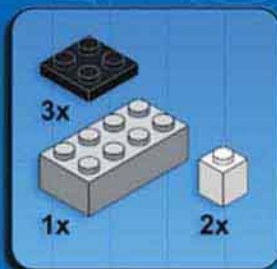





5

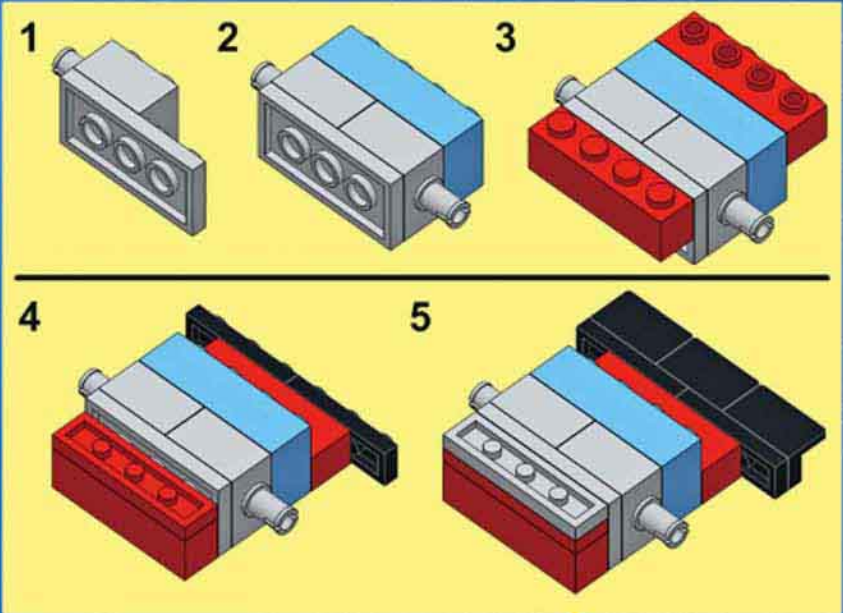
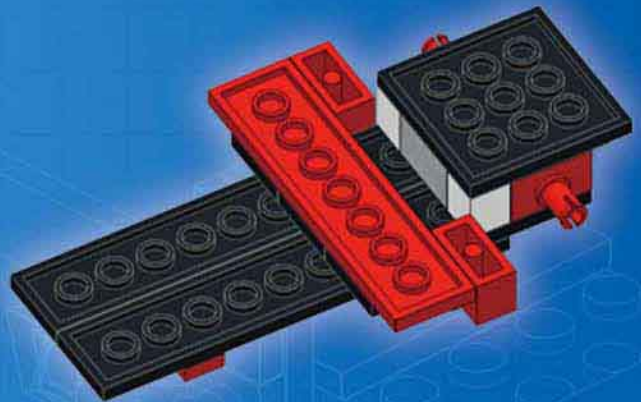
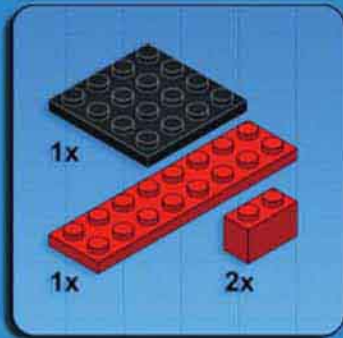

6

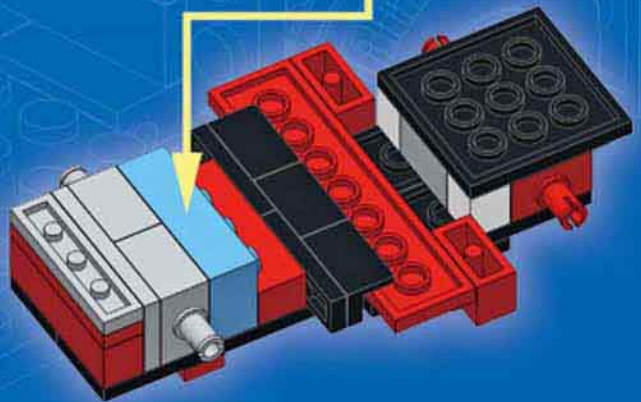
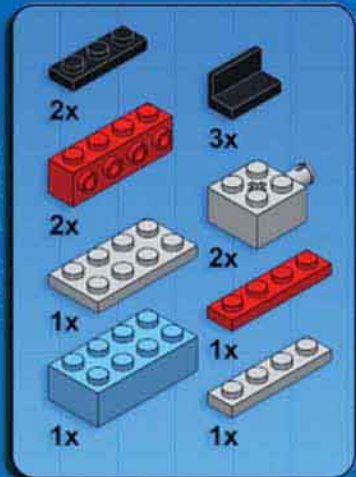

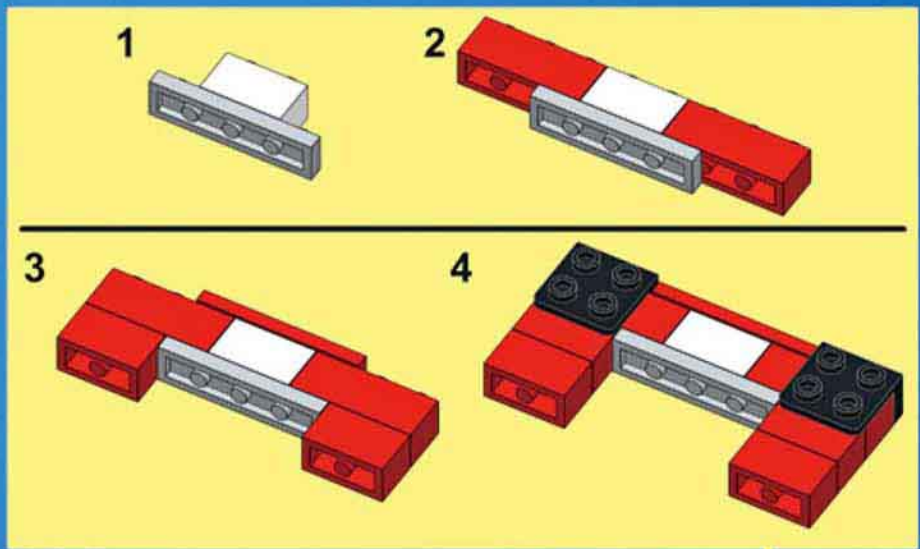

7

- 1x [Black 2-hole Technic brick]
- 1x [White 1-hole Technic brick]
- 2x [Red 3-hole Technic brick]
- 1x [Red 1-hole Technic brick]
- 1x [Red 1-hole Technic brick]
- 4x [Red 1-hole Technic brick]
- 1x [White 1-hole Technic brick]
- 2x [Black 2-hole Technic brick]
- 1x [White 1-hole Technic brick]
- 1x [Black 2-hole Technic brick]

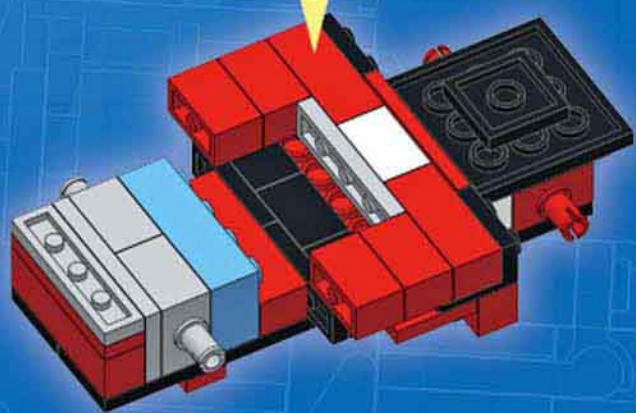

8

- 1x [Red 5-hole Technic brick]

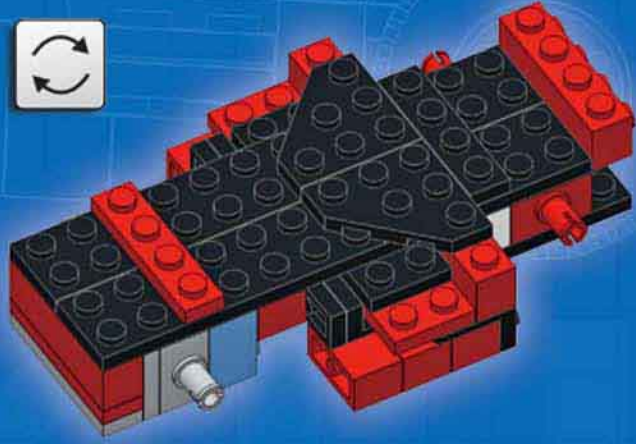



9

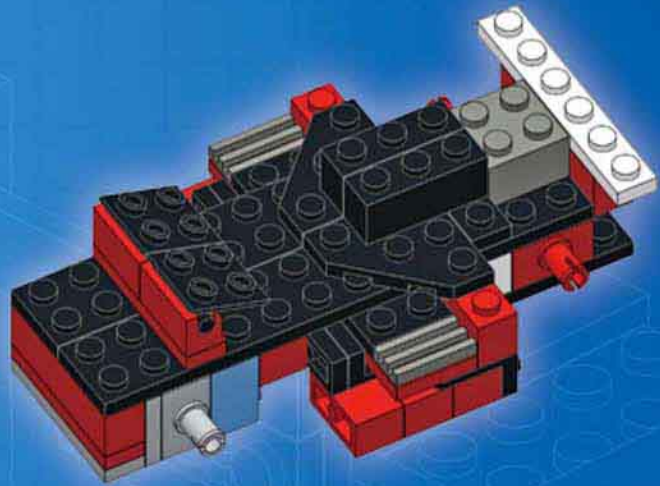
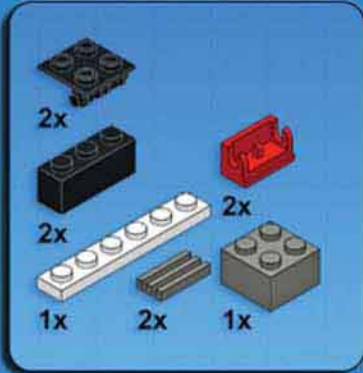

10

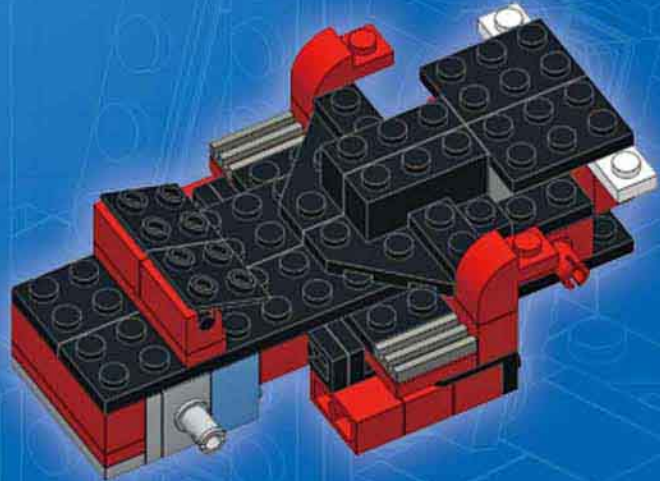

11

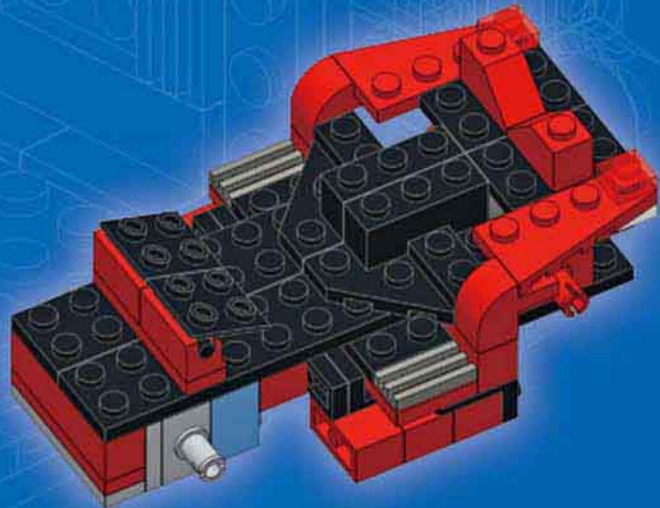
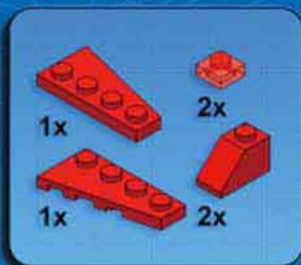



12

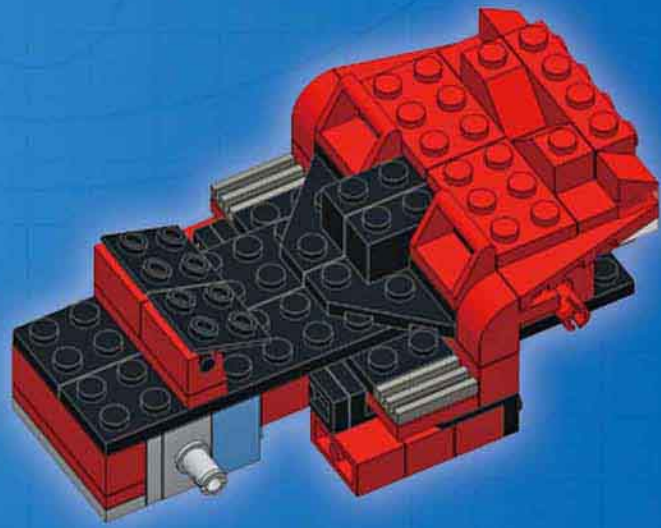
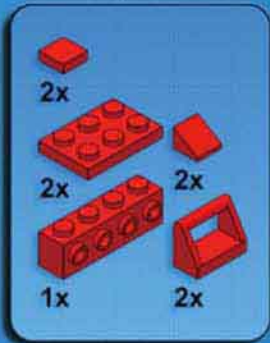

13

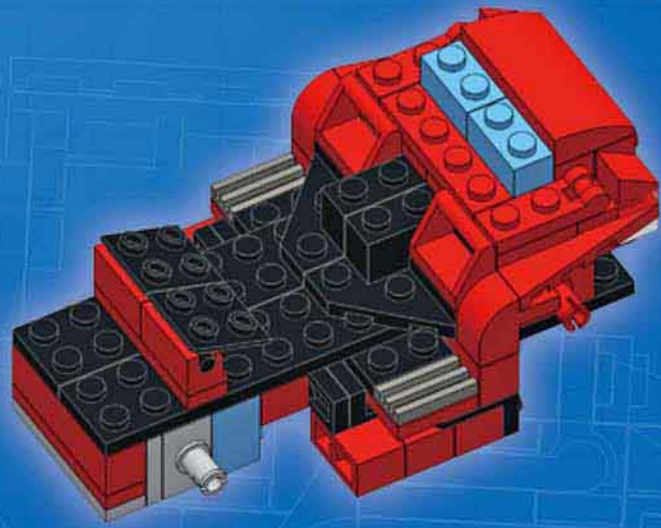
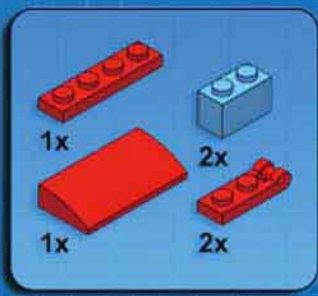

14

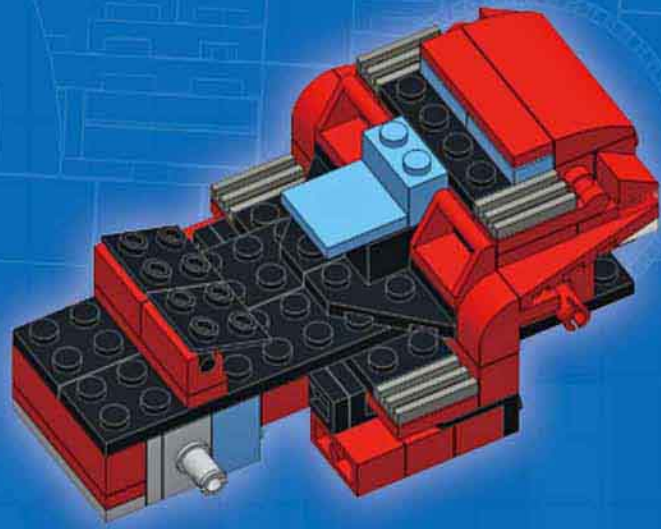
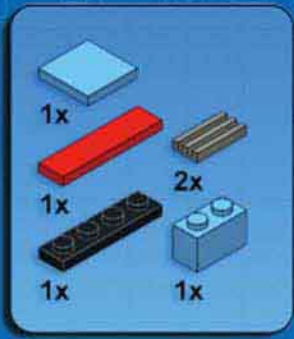



15

- |    |    |
|----|----|
|    |    |
| 1x | 1x |
|    |    |
| 1x | 1x |
|    |    |
| 1x | 1x |
|    |    |
| 1x | 1x |
|    |    |
| 1x | 1x |

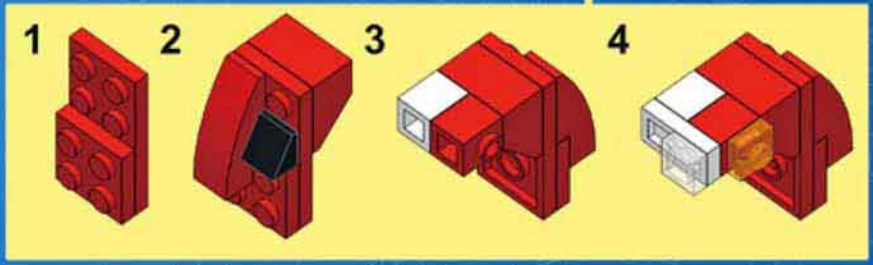
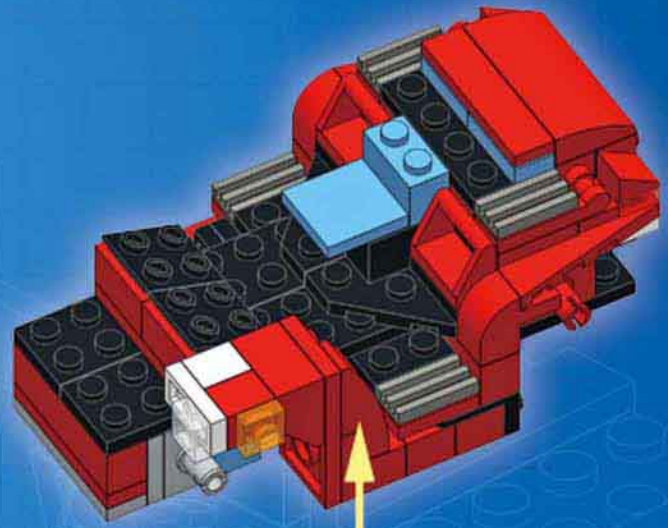

16

- |    |    |
|----|----|
|    |    |
| 1x | 1x |
|    |    |
| 1x | 1x |
|    |    |
| 1x | 1x |
|    |    |
| 1x | 1x |
|    |    |
| 1x | 1x |

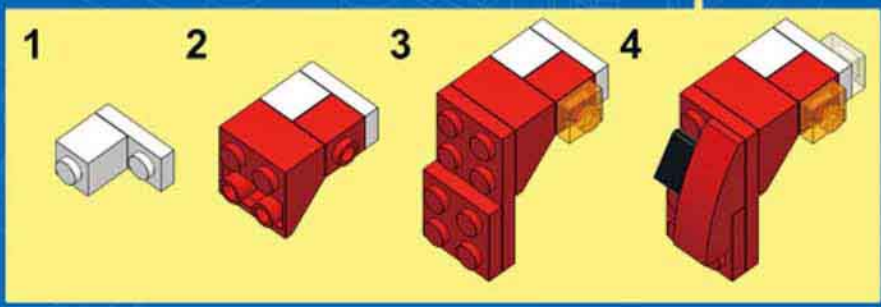
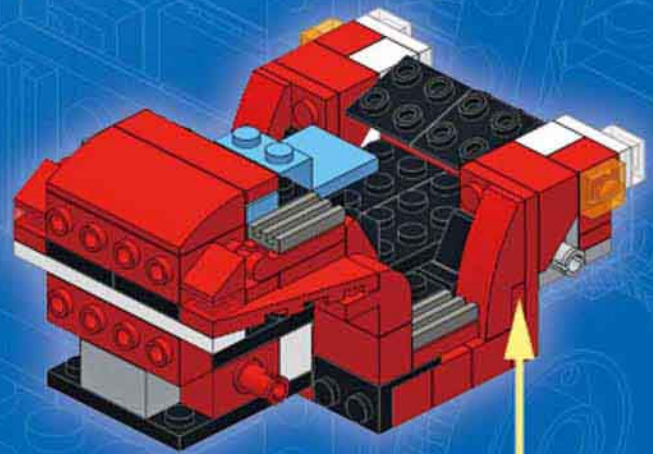



17

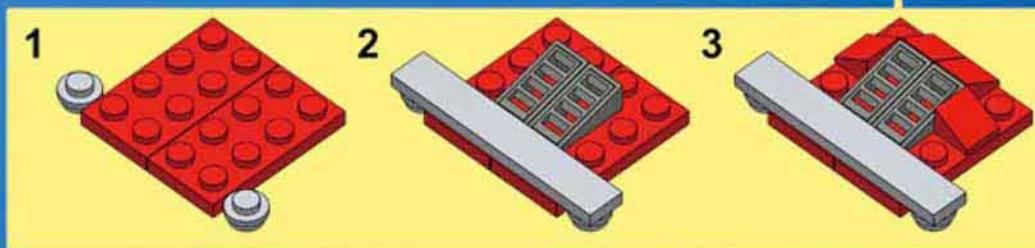
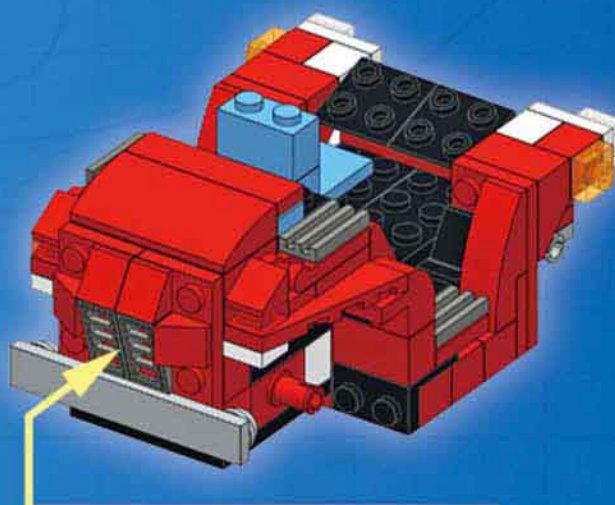
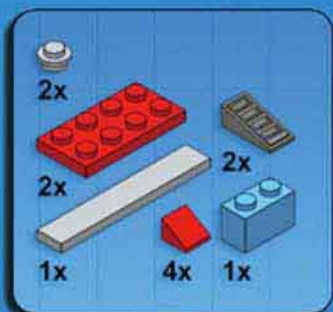

18

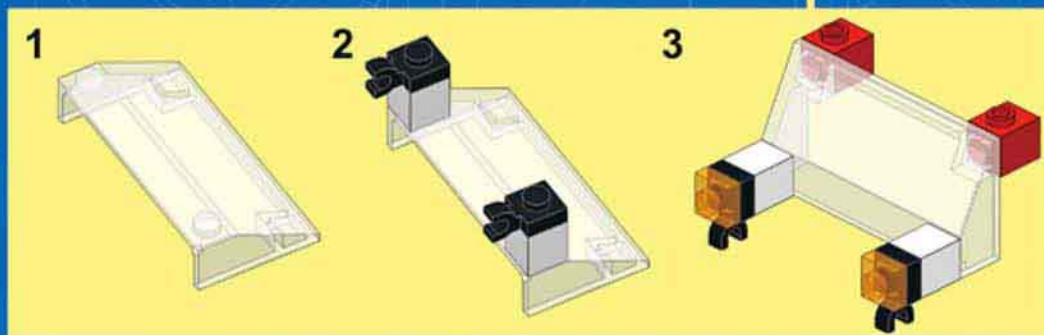
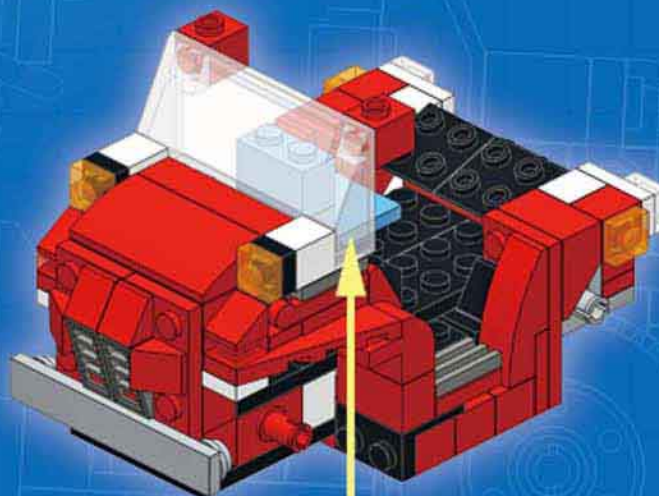
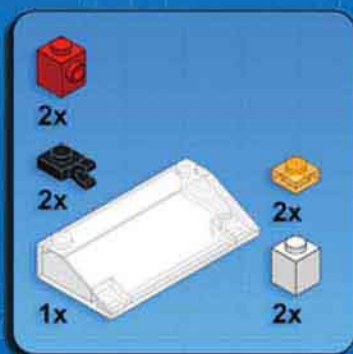

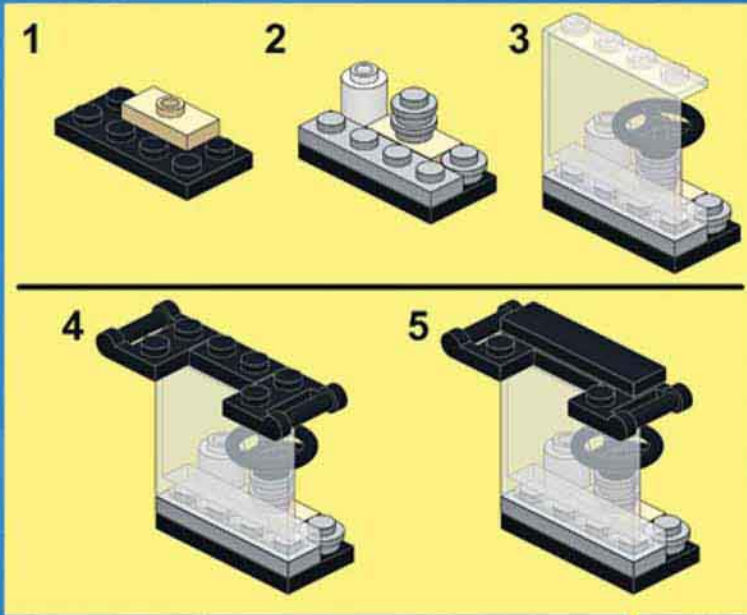

19

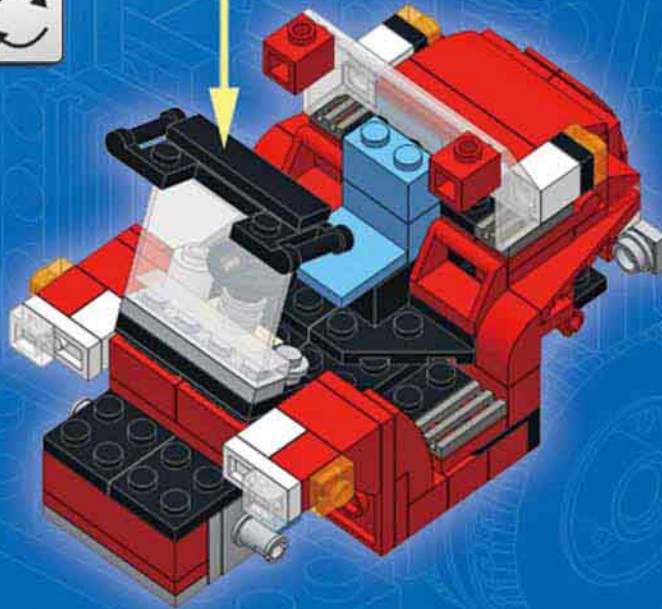
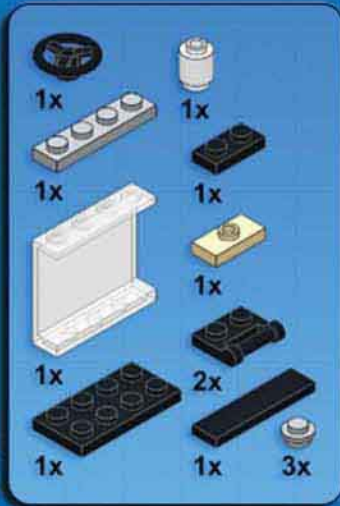



20

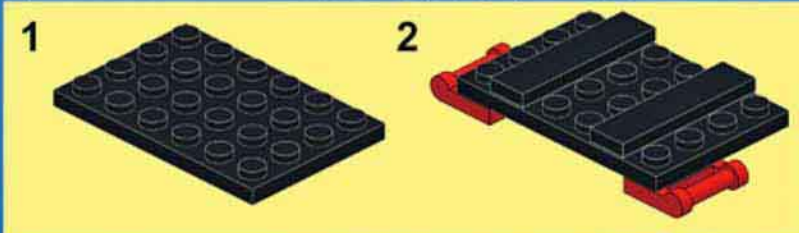
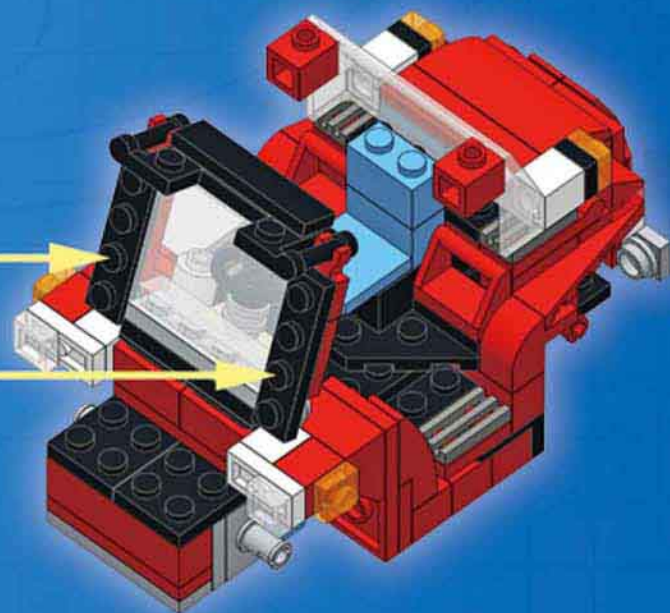
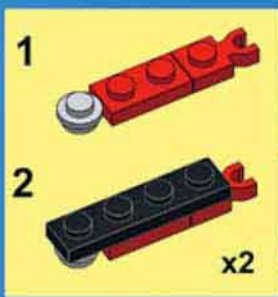
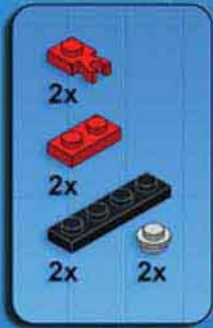

21

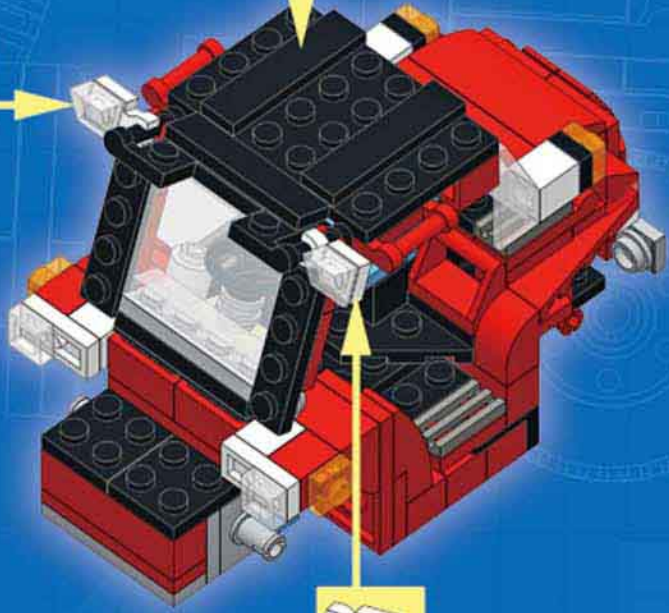





22

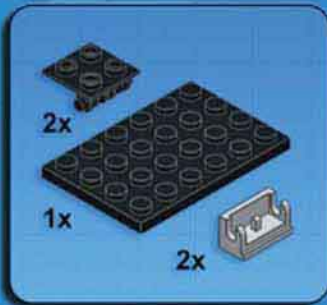

1

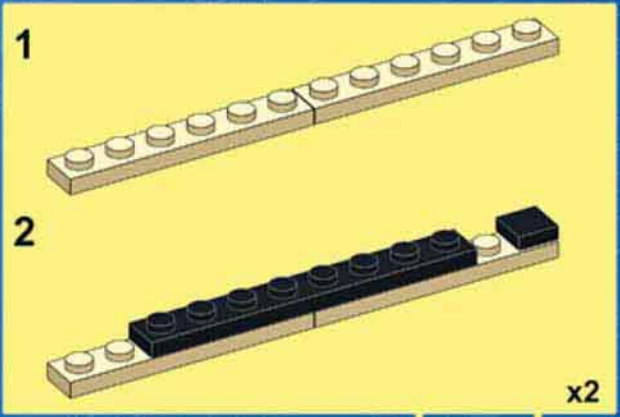

2

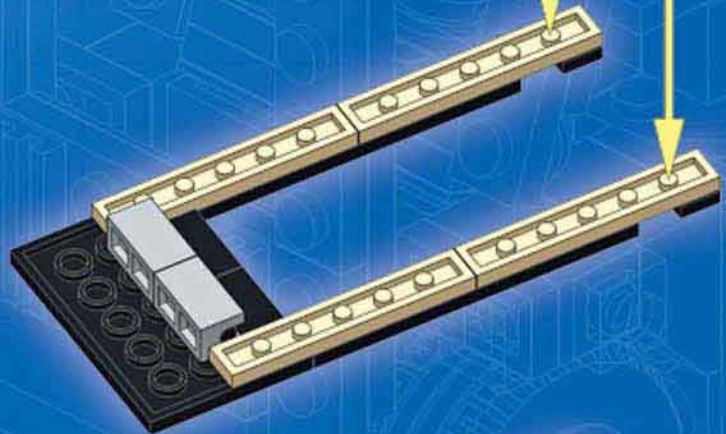
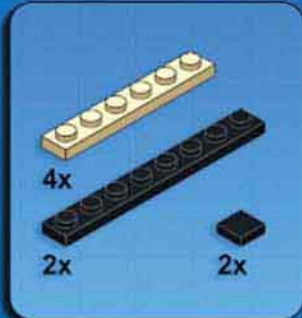

3

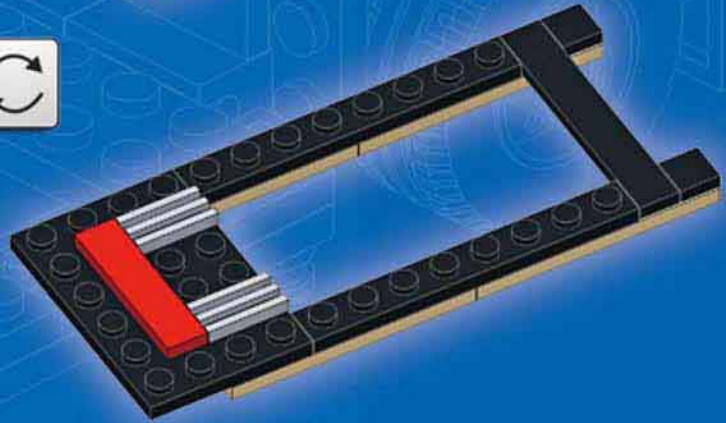
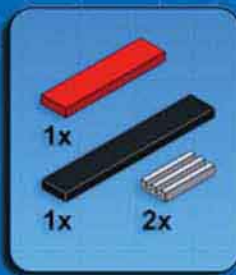

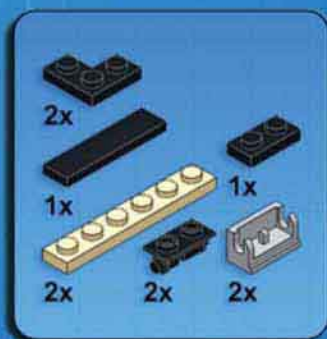

4

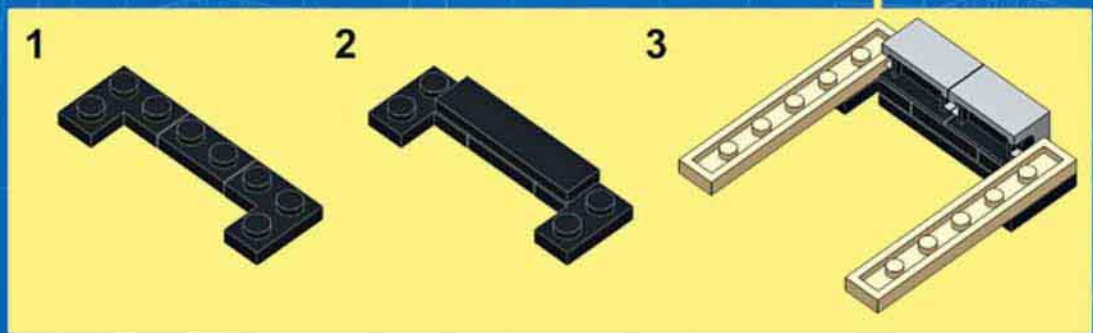
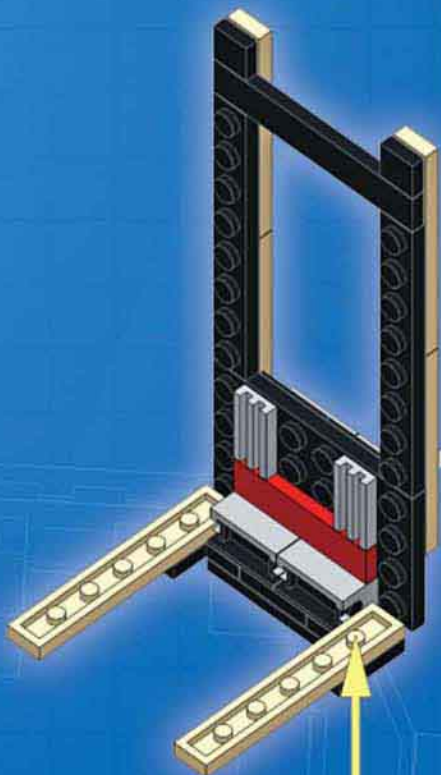

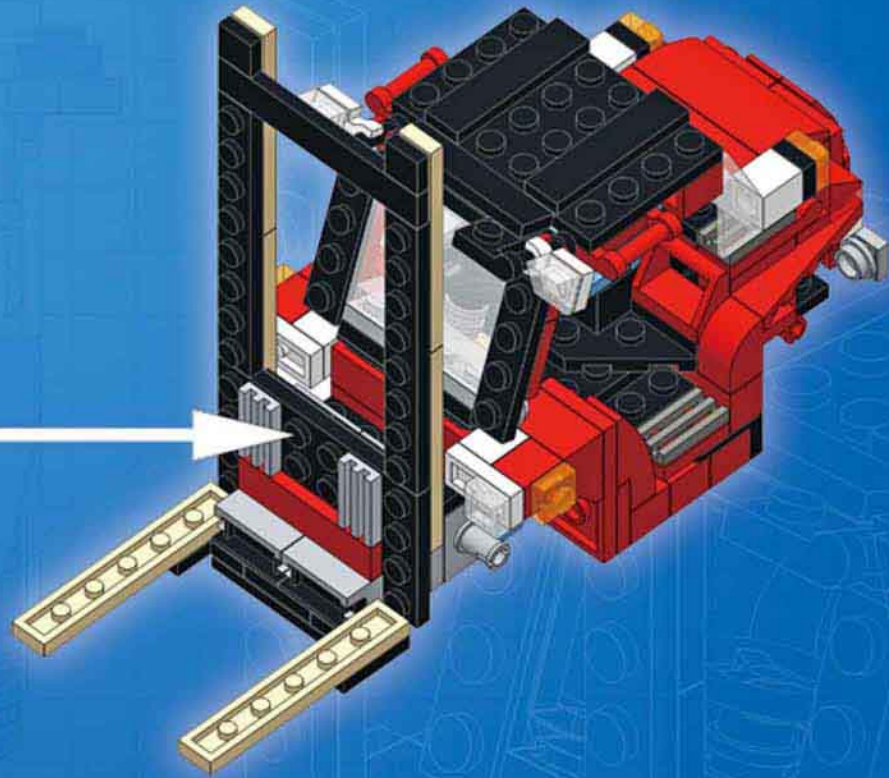

23

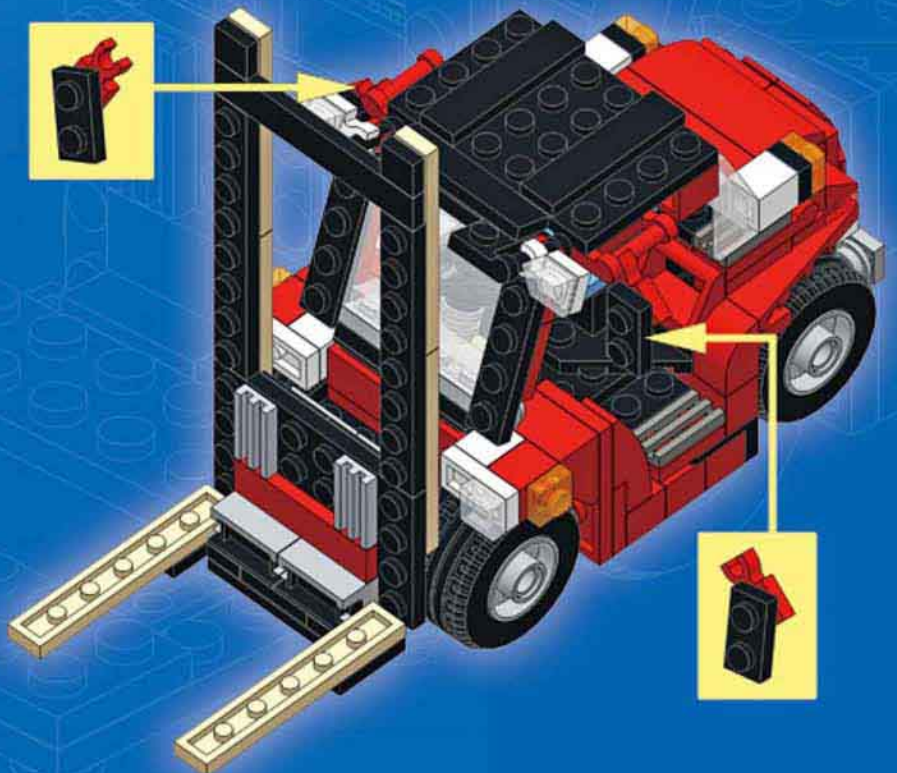



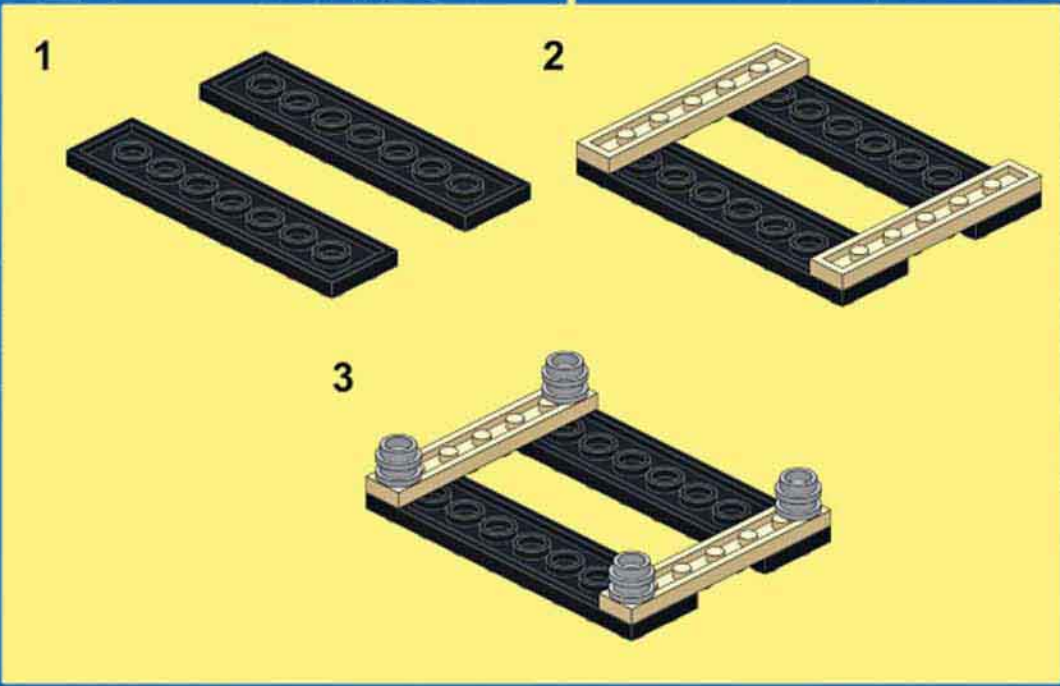
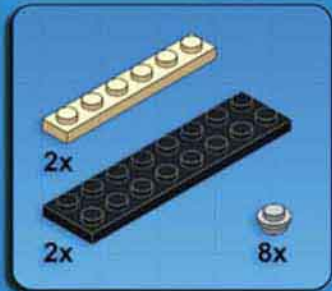

24





Complexity   
 Functions   
 Pieces 

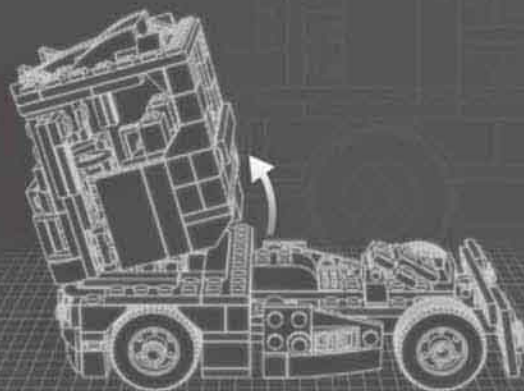

## BIG RIG

Design notes: spacious cabin, big mirrors, massive grille, airfoil, fifth wheel, mudguards

### Technical specifications:

Dimensions (l × w × h): 20 × 14 × 14 studs

Wheelbase: 12 studs

Axle width front/rear: 10/10 studs

Features: opening doors, tipping cabin



1

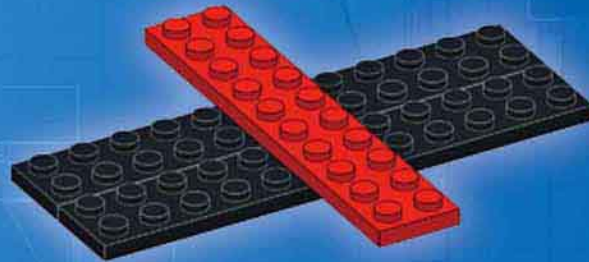
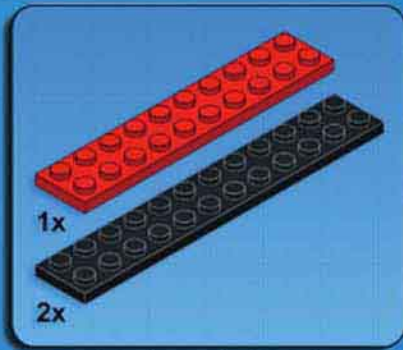

2

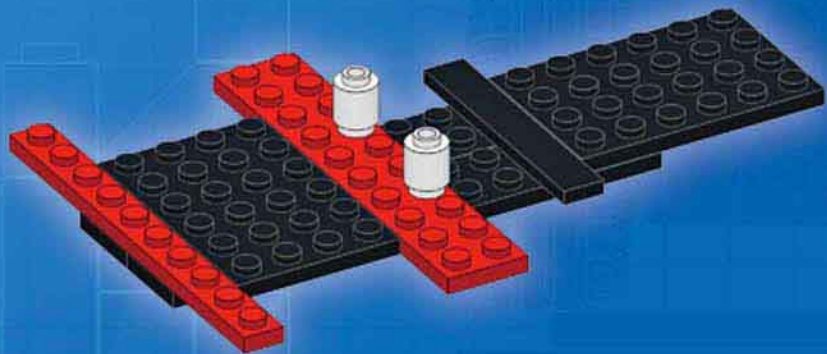
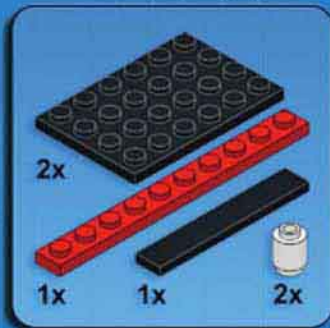

3

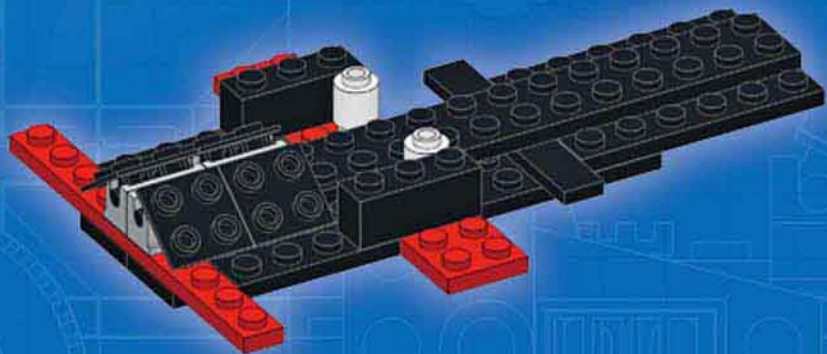
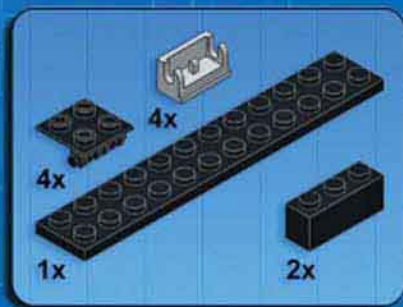

4

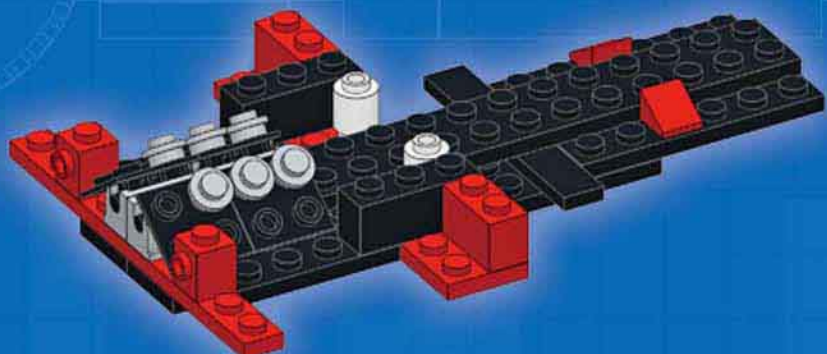
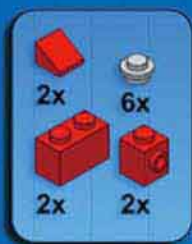



5

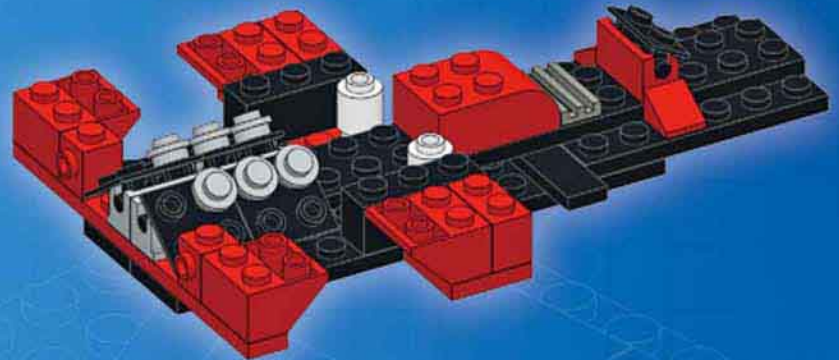
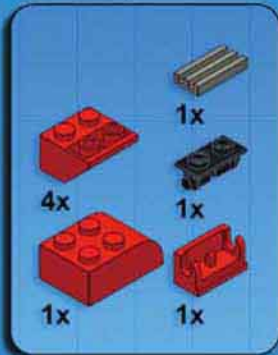

6

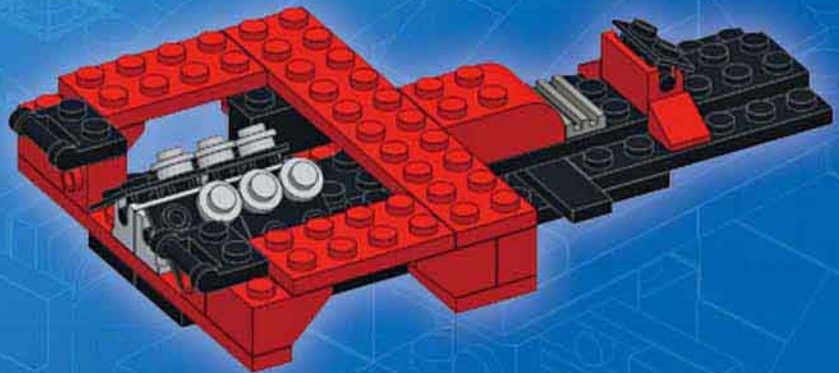
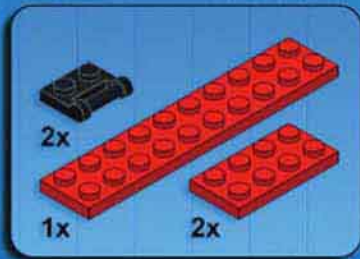

7

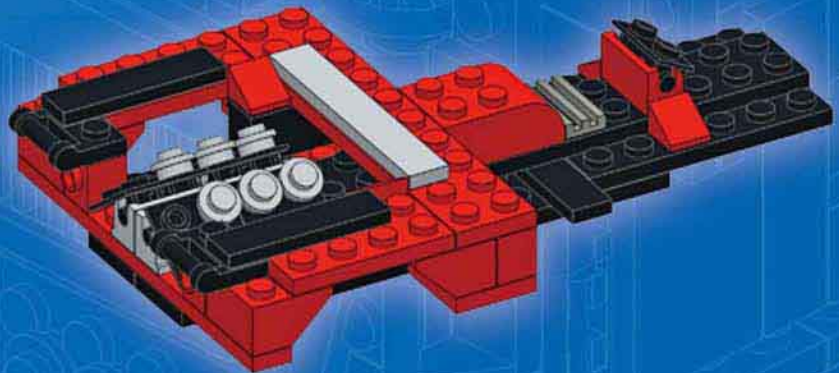
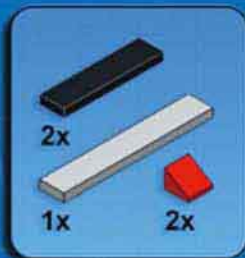

8

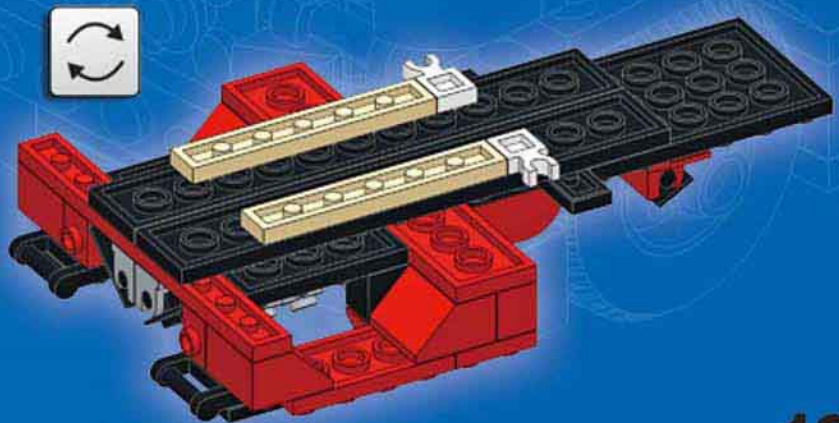
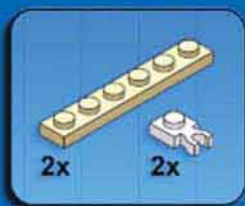



9

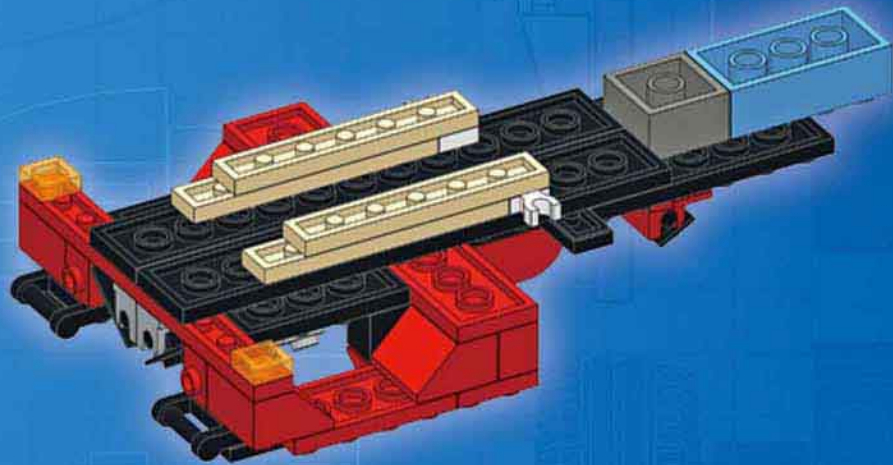
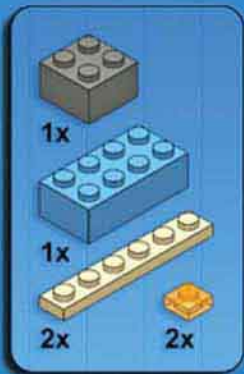

10

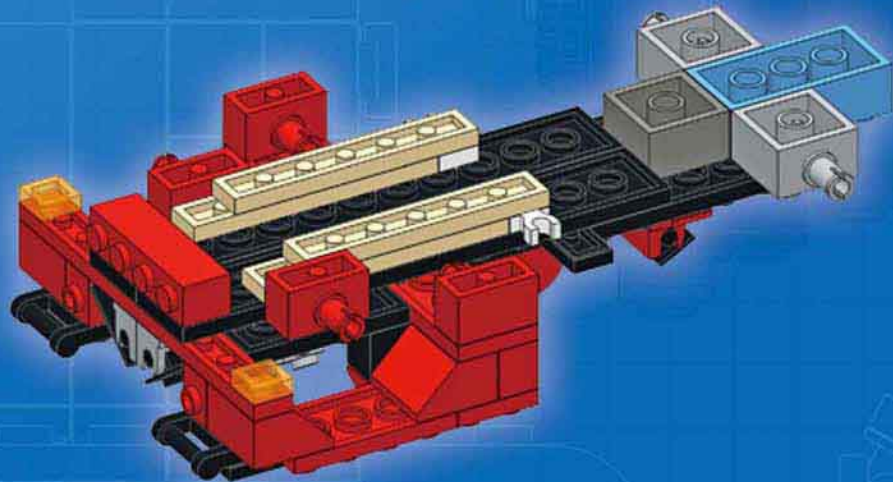
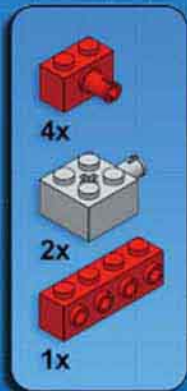

11

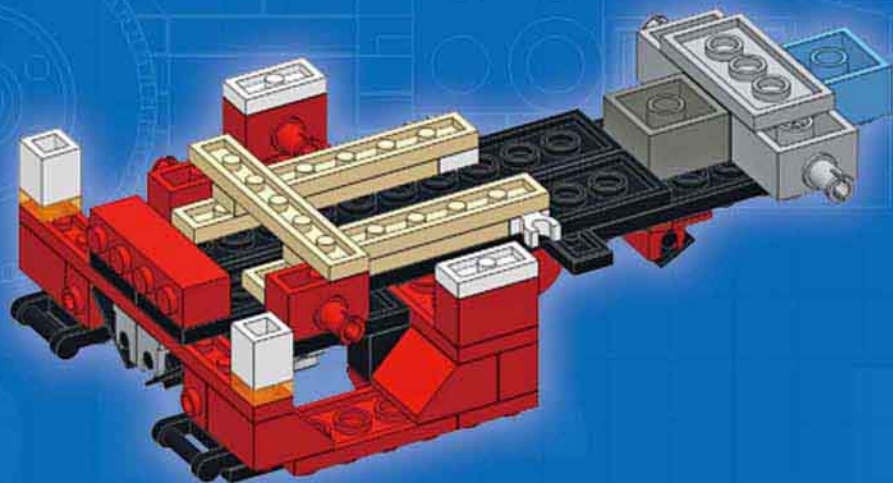
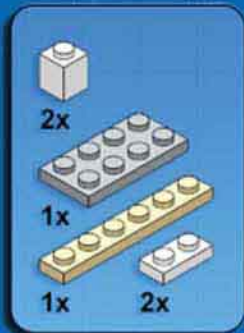







14

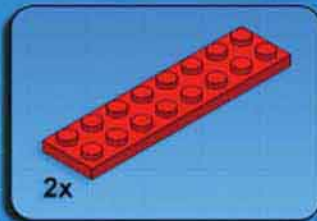

1

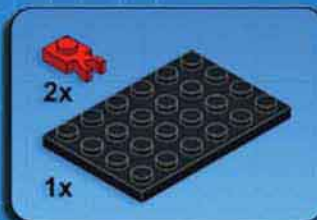
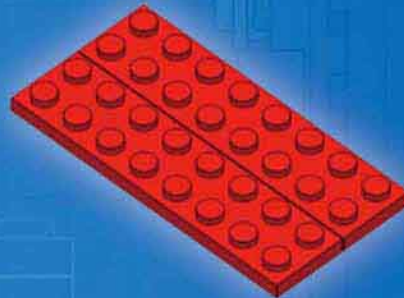

2

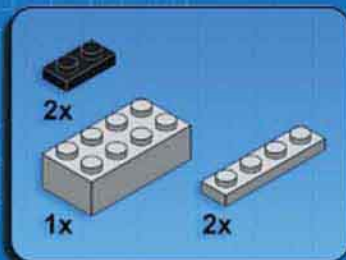
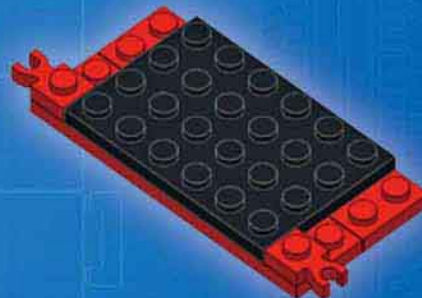

3

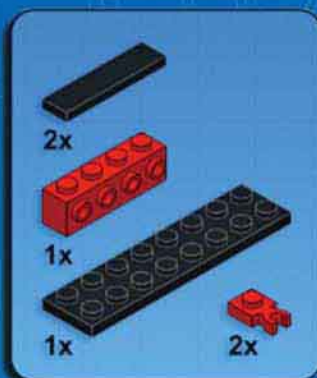
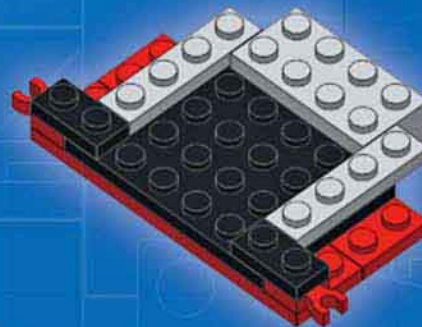

4

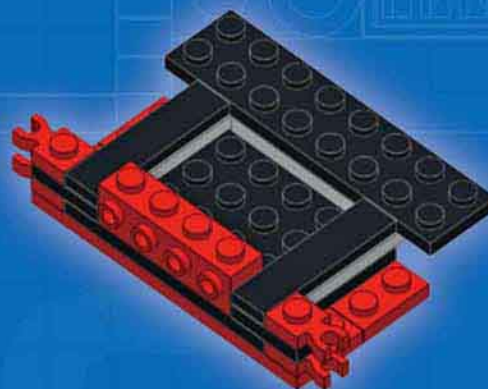

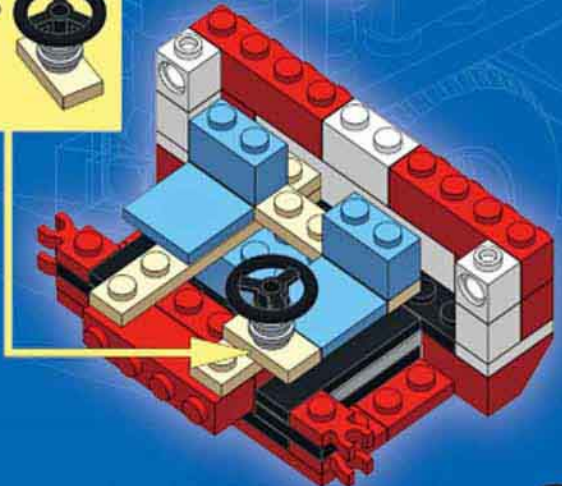
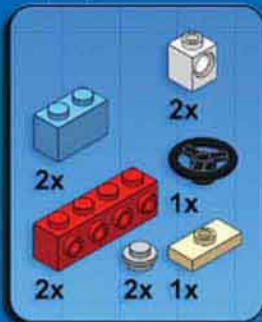
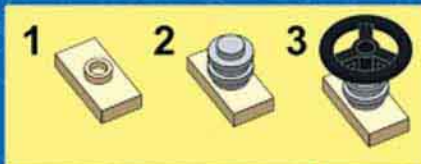
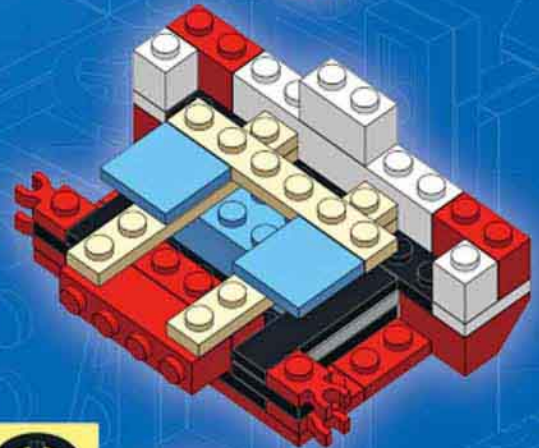
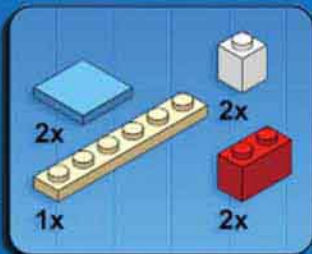
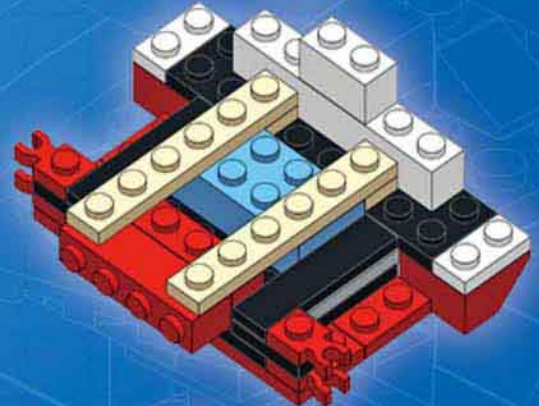
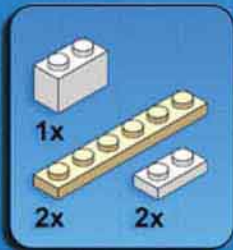
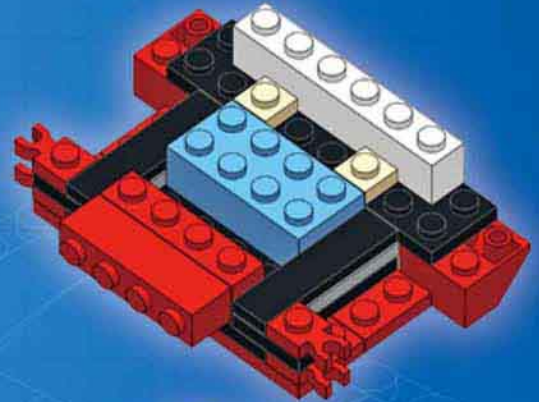
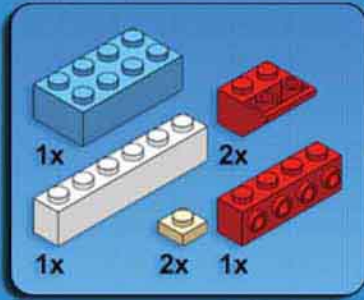

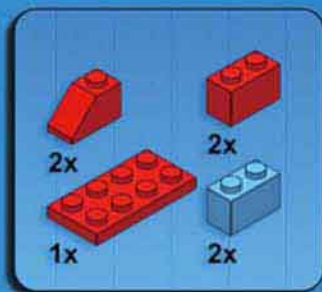

9

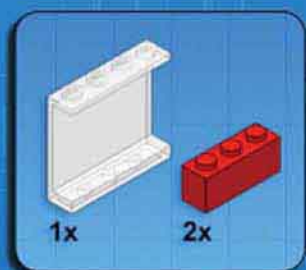
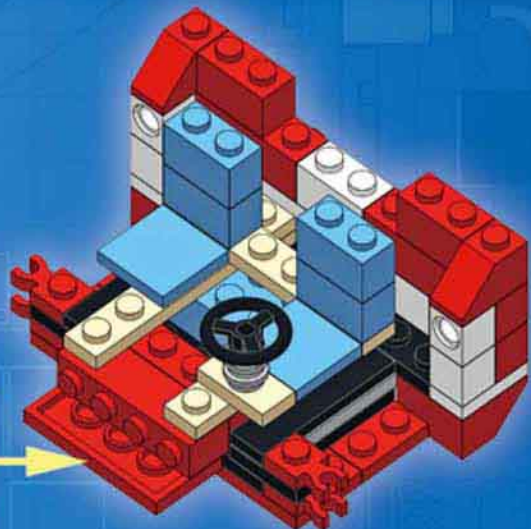

10

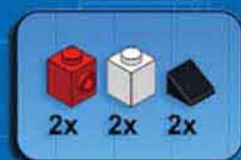
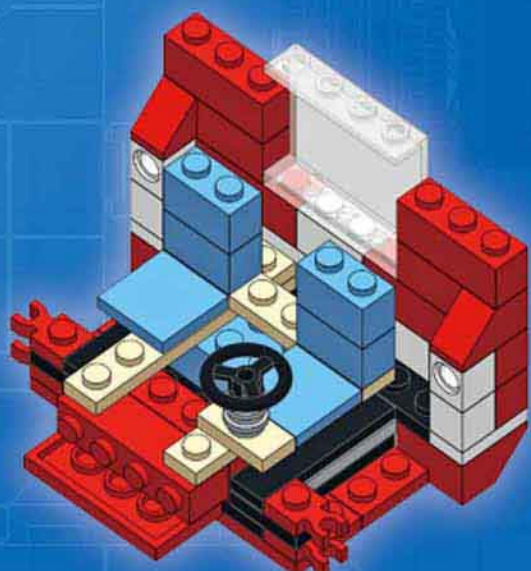

11

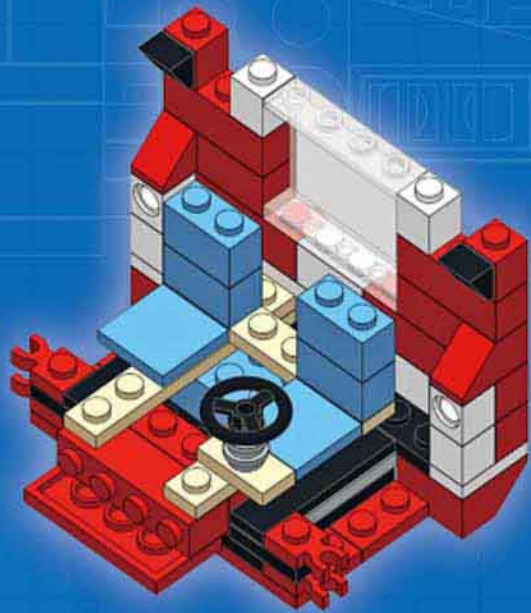



15

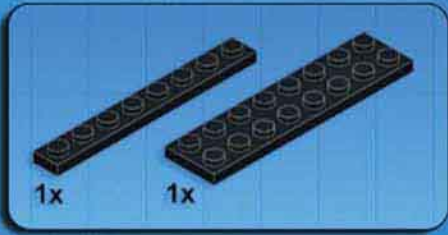

1

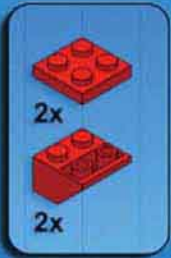

2

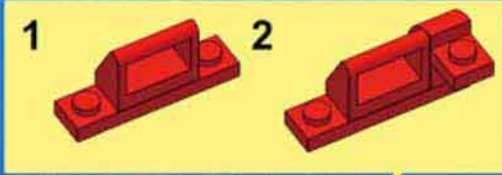
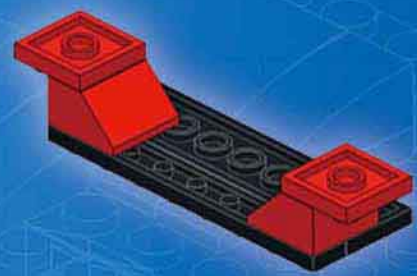

3

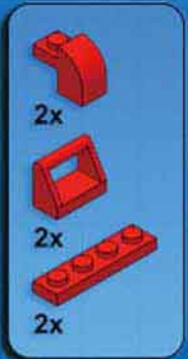
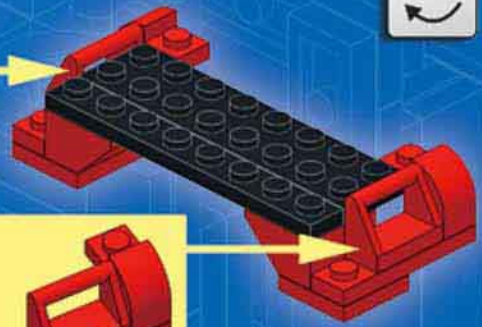

4

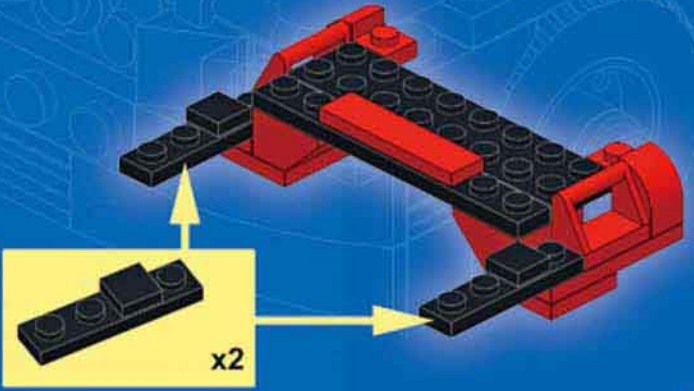
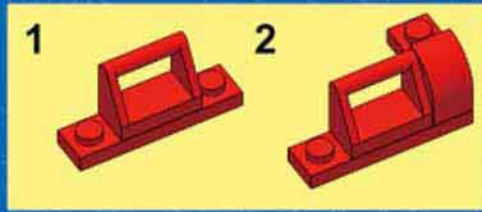

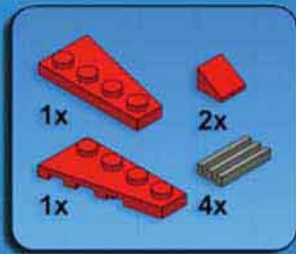

5

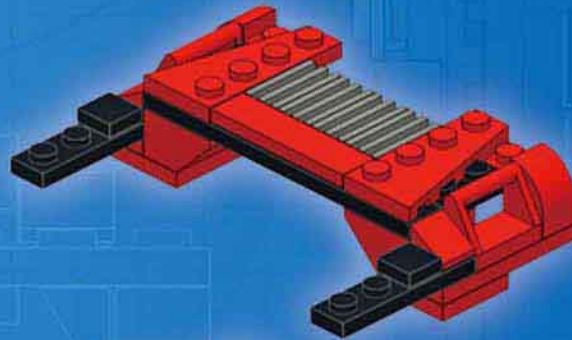

6

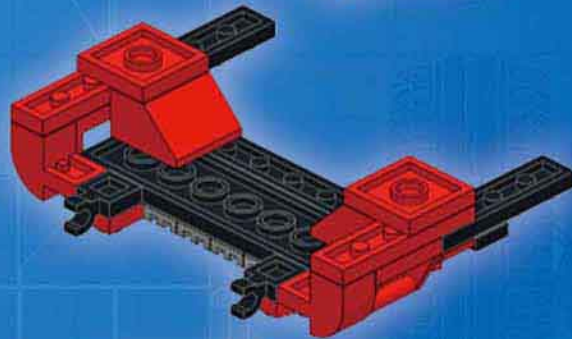

7

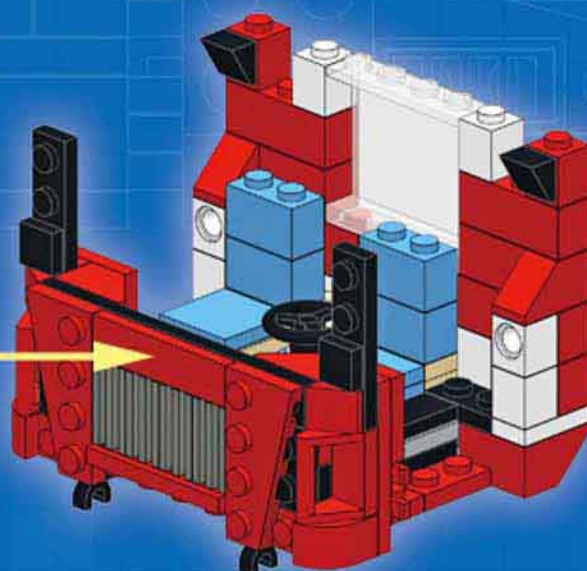
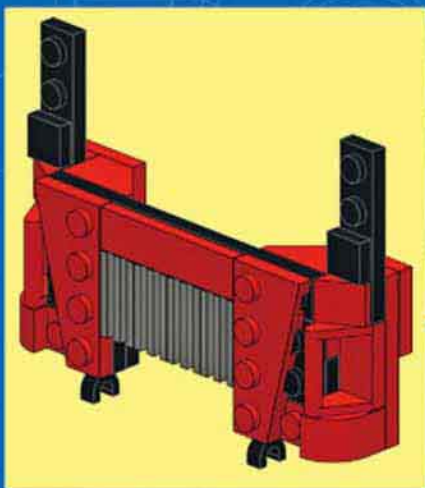
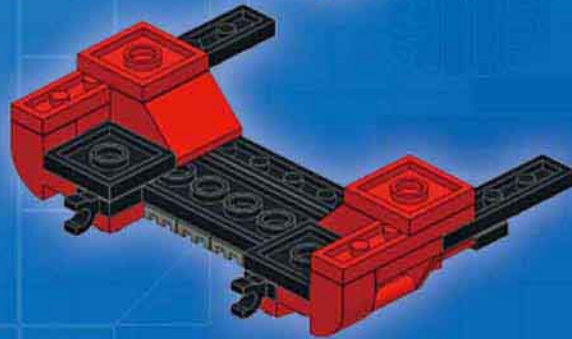



16

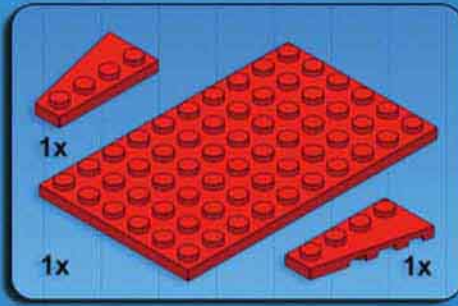

1

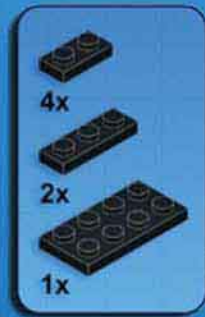
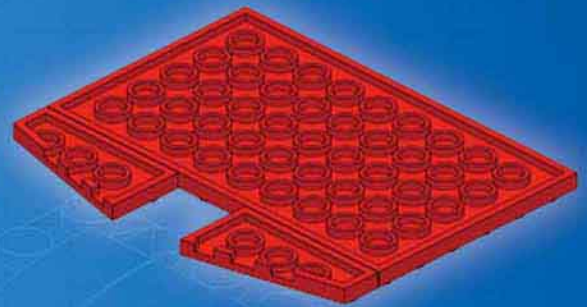

2

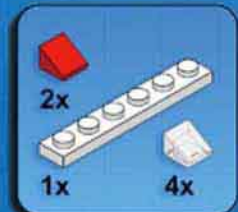
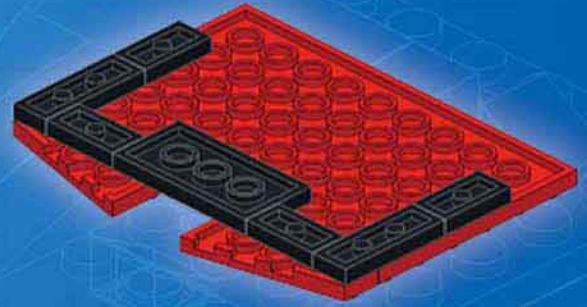

3

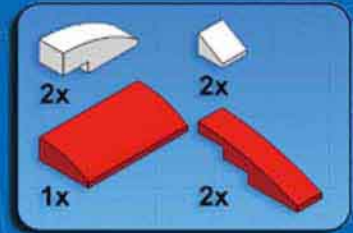
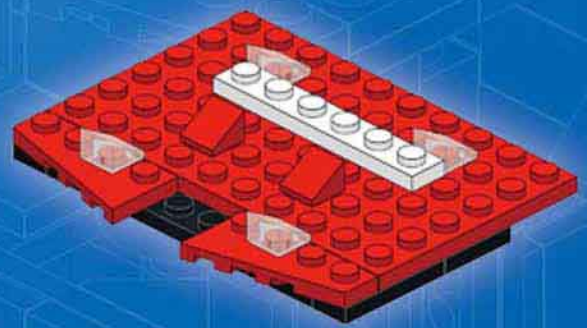

4

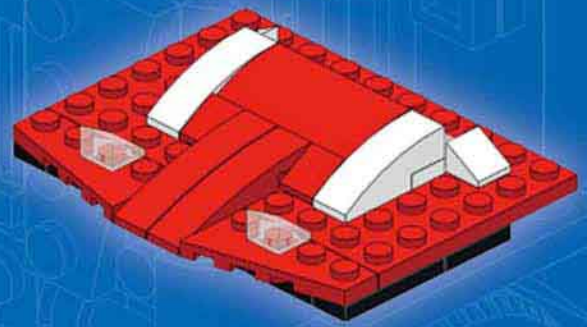

5

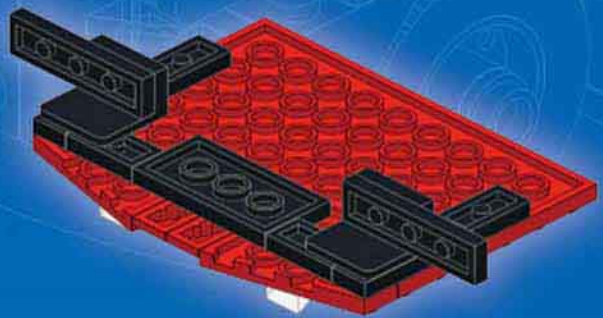

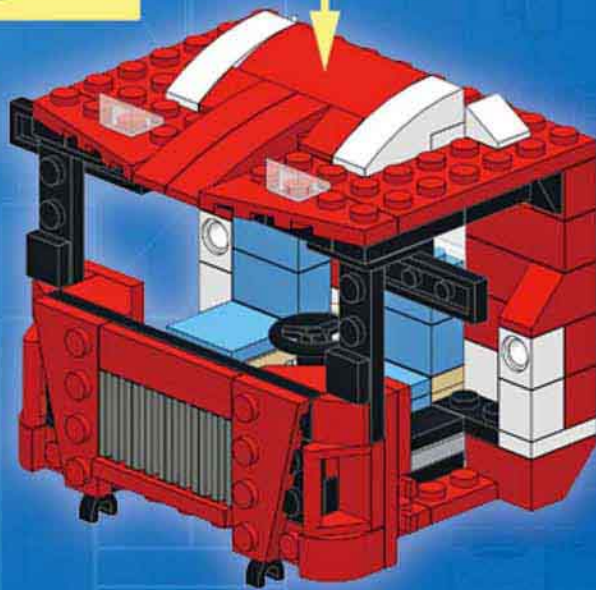
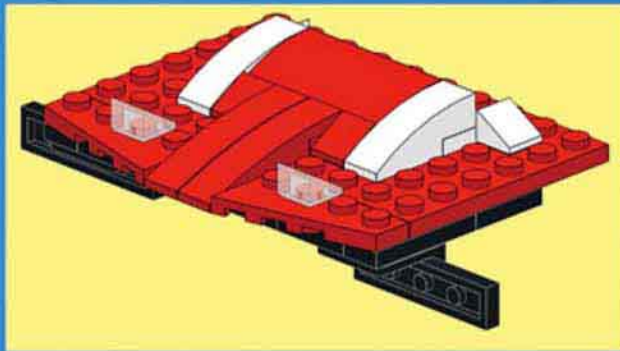

x2





17

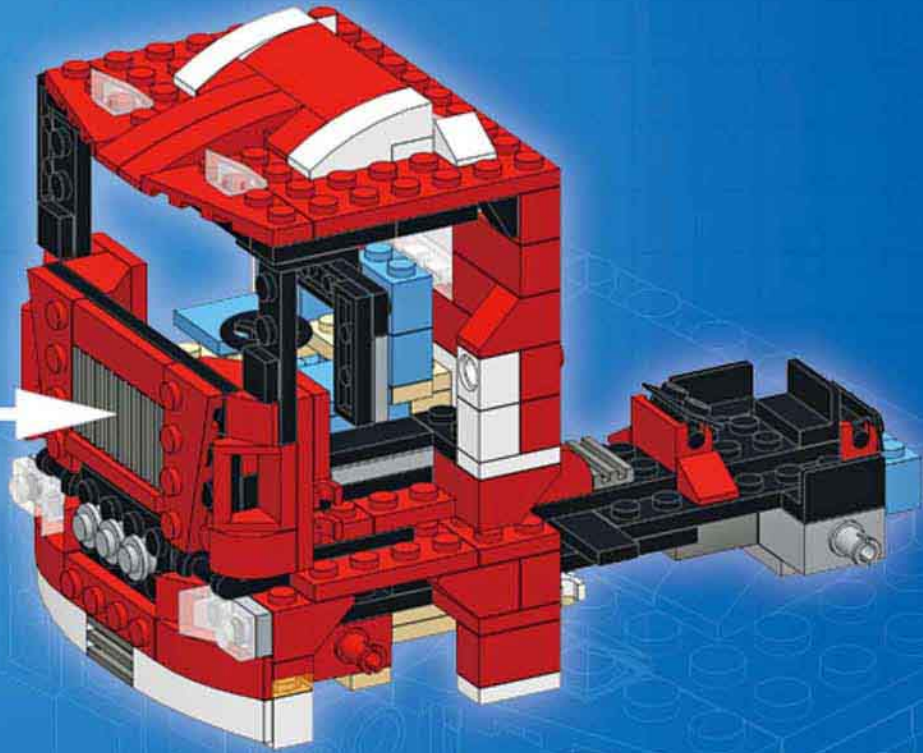





18

-  1x
-  1x
-  1x
-  1x
-  1x

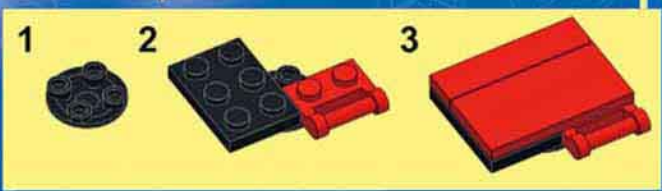
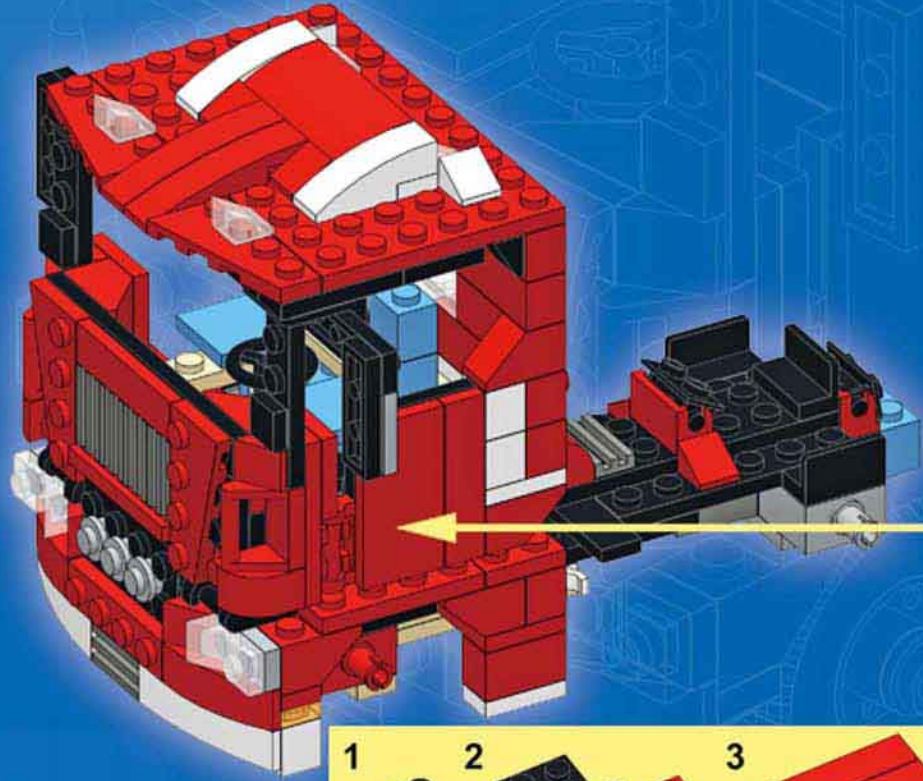



19

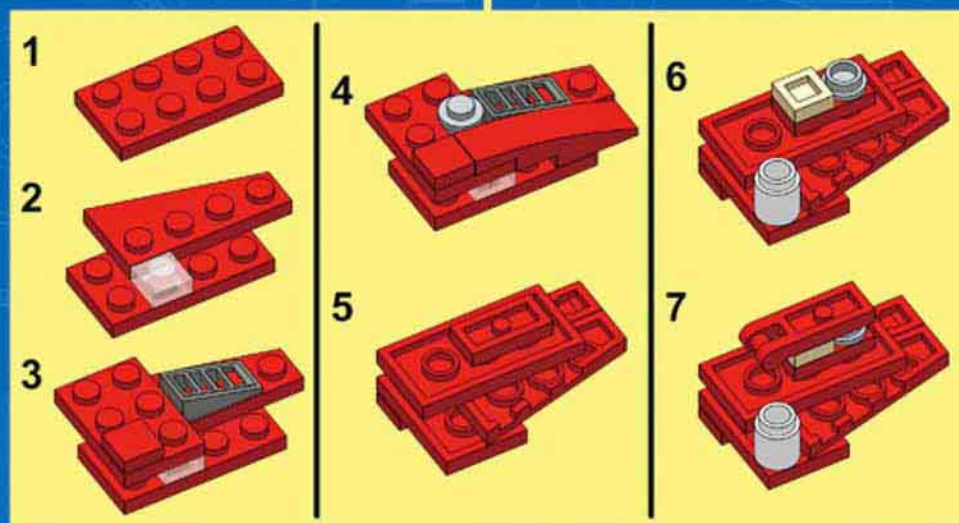
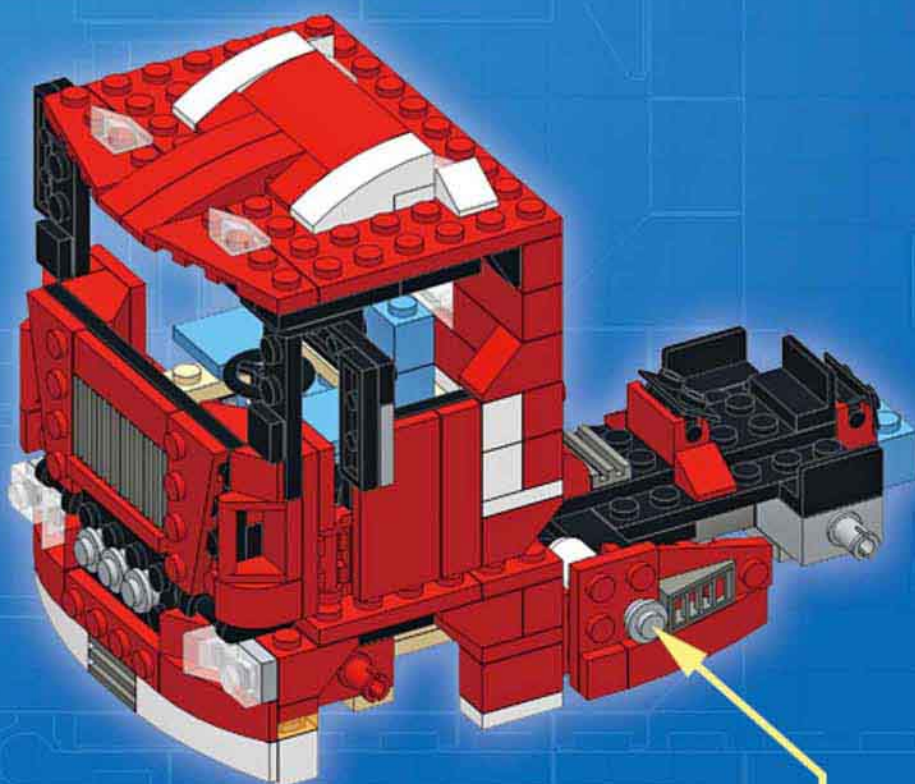
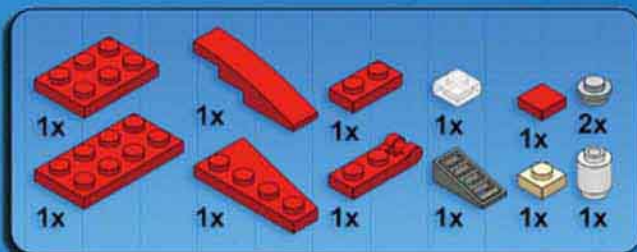



20

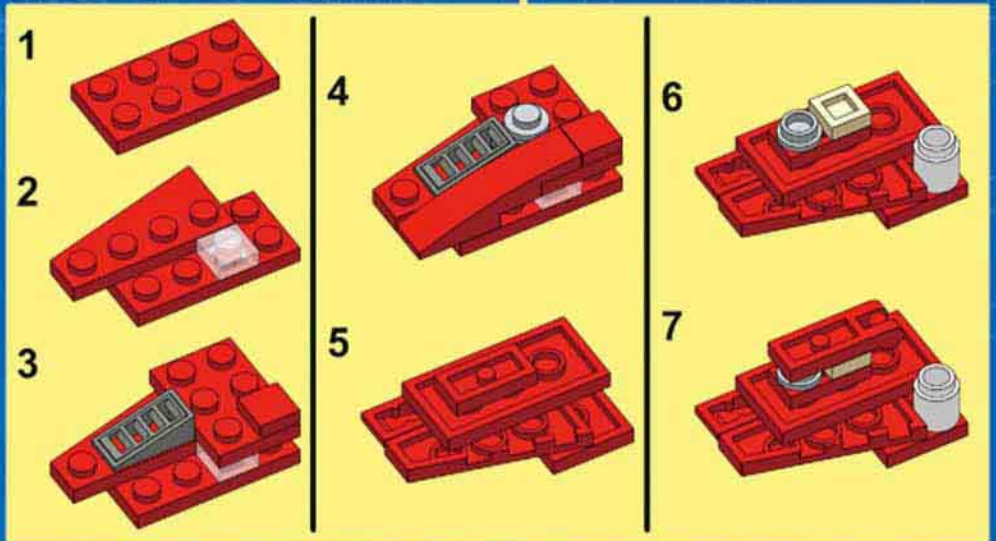
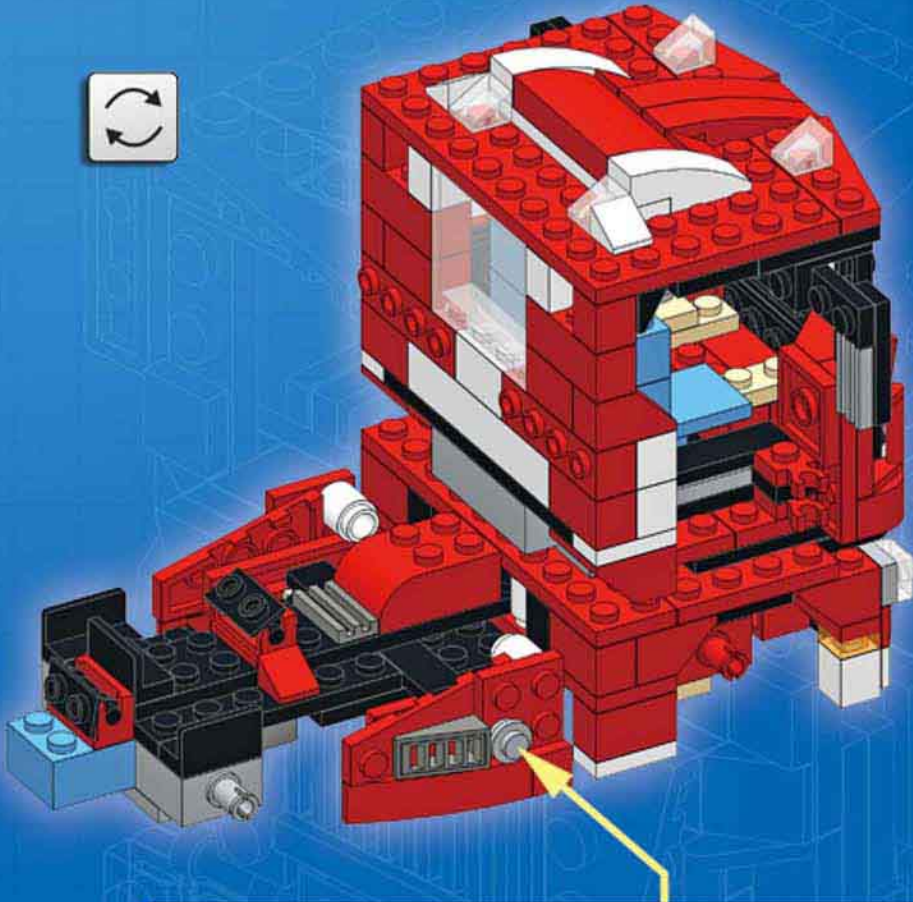
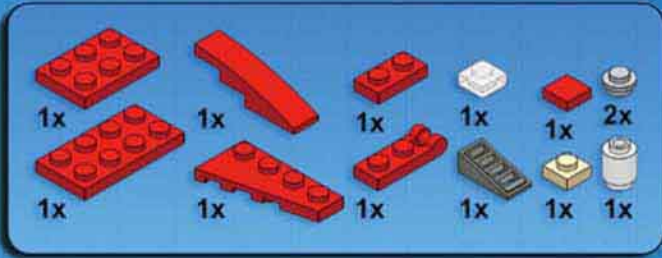



21

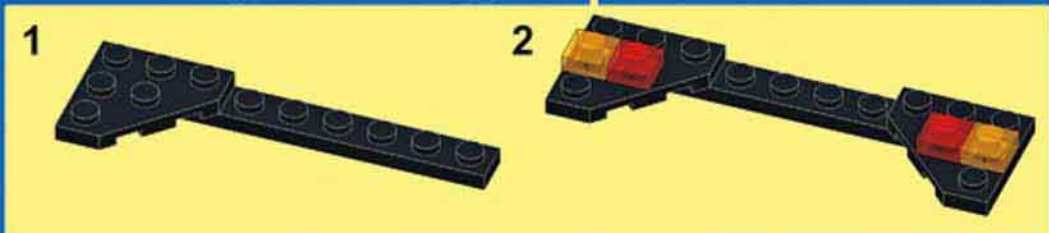
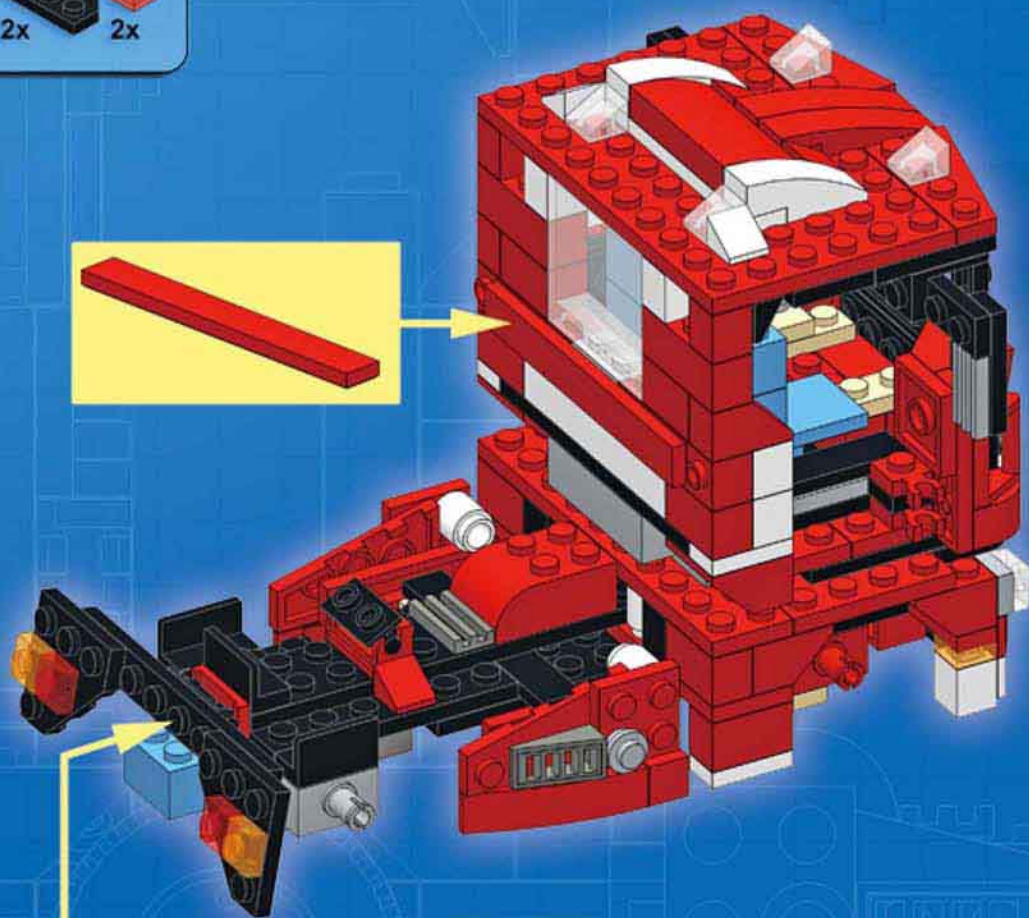
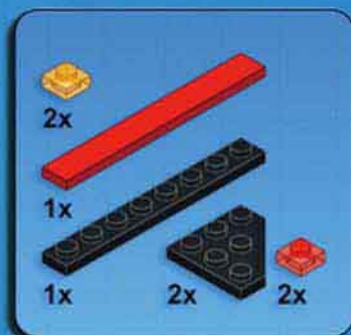



22

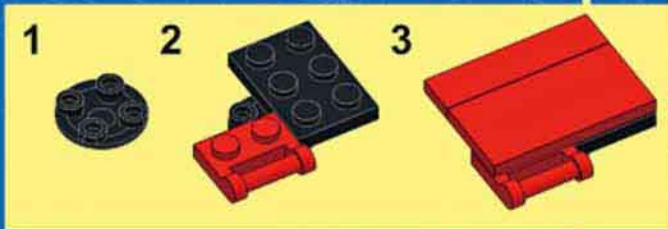
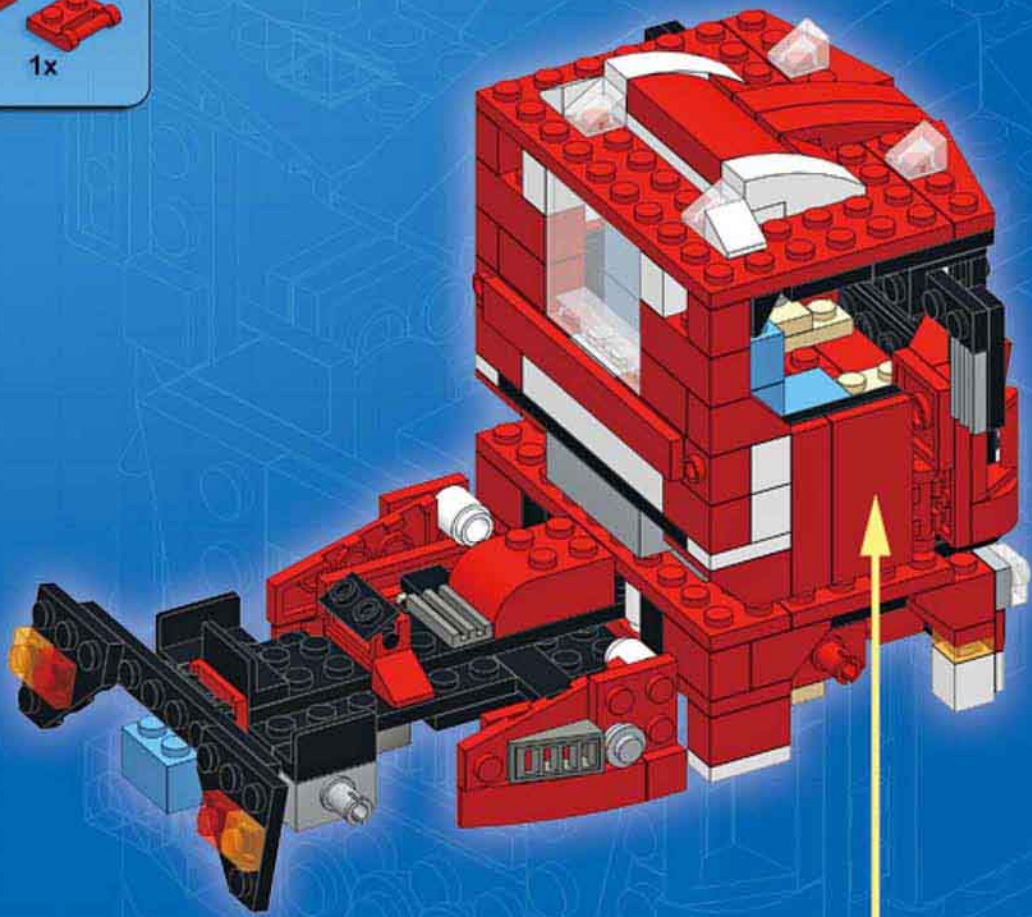
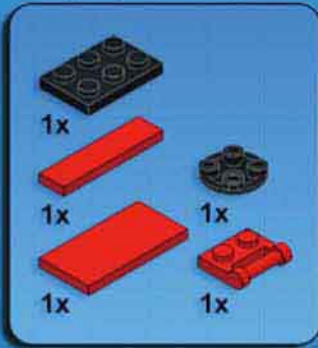



23





Complexity   
 Functions   
 Pieces 

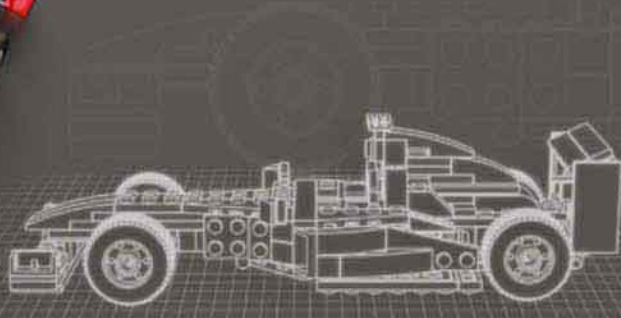
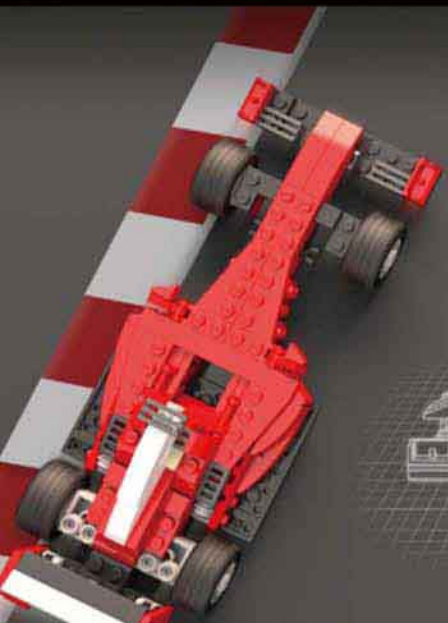
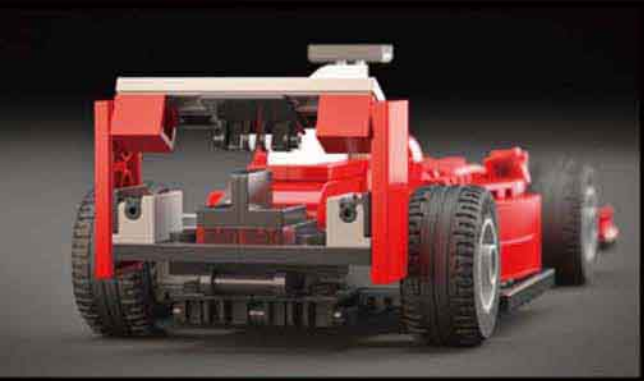

**F1 RACER**

Design notes: low chassis, aerodynamic shape, open-wheeled design, air intakes, front and rear wings

Technical specifications:  
 Dimensions (l x w x h): 27 x 10 x 8 studs  
 Wheelbase: 17 studs  
 Axle width front/rear: 10/10 studs



1

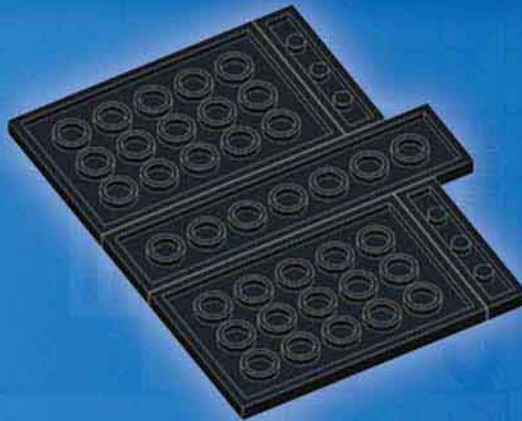
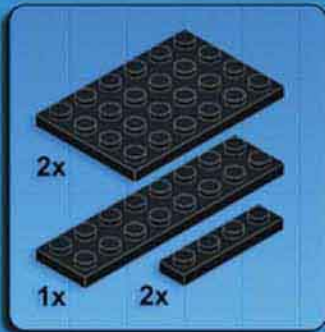

2

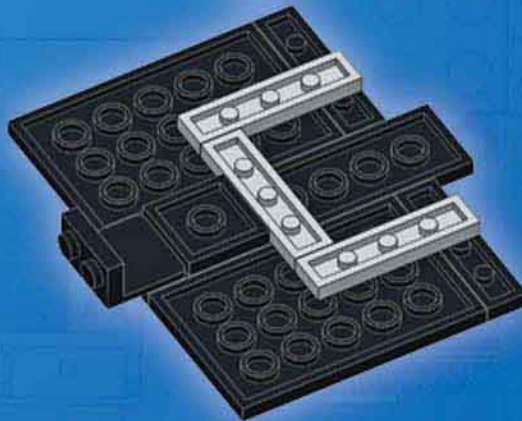
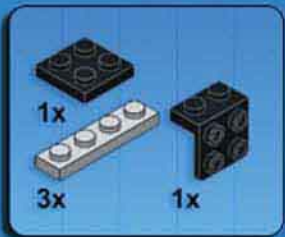

3

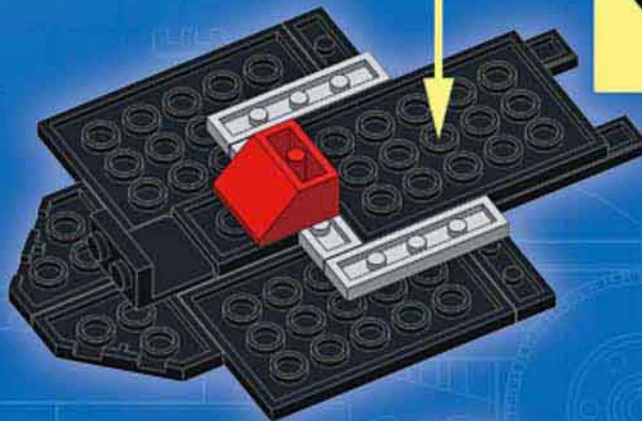
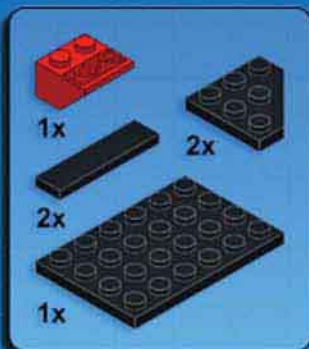

4

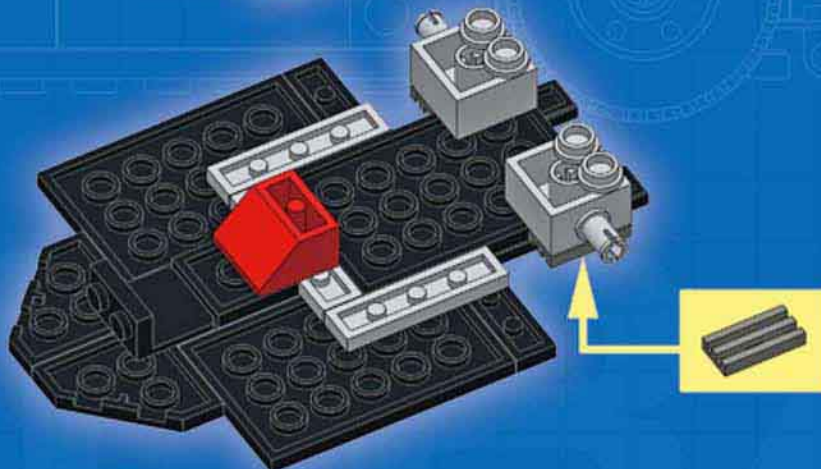
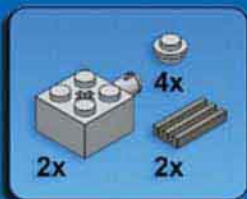





5

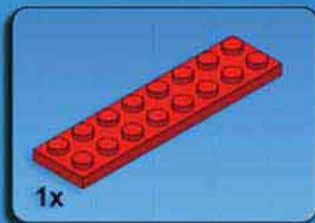

1

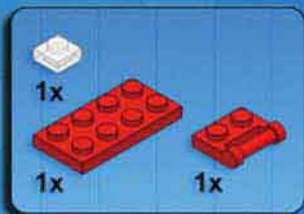
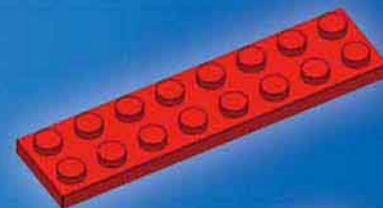

2

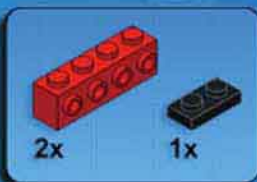
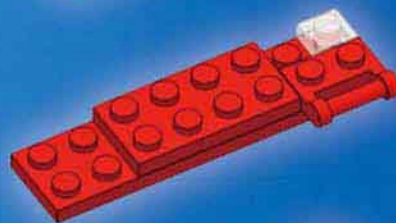

3

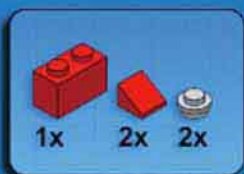
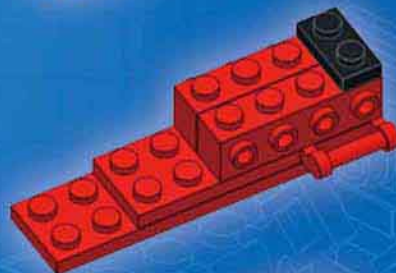

4

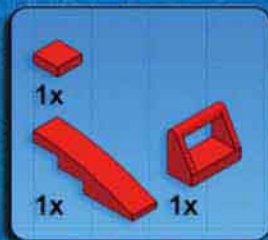
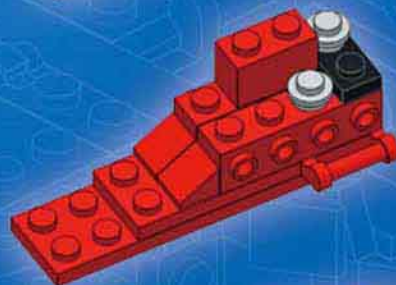

5

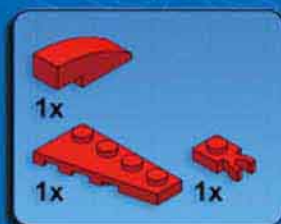
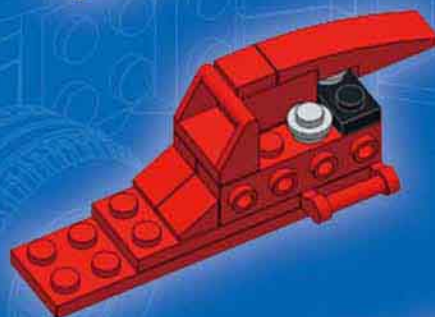

6

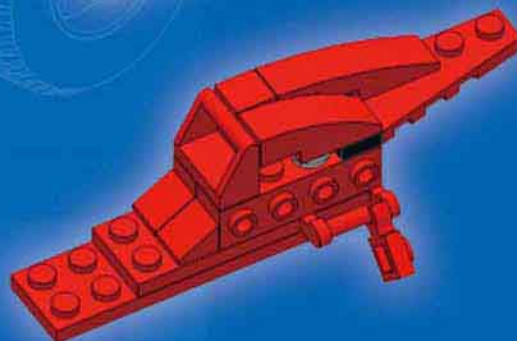

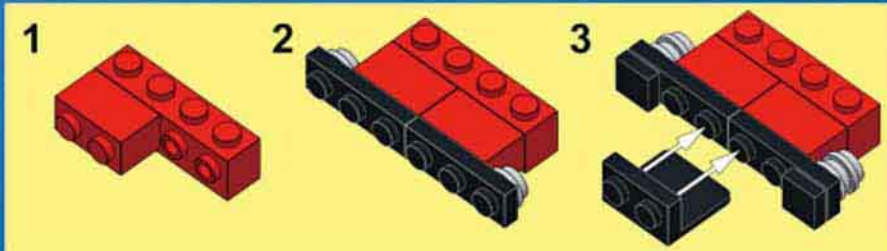
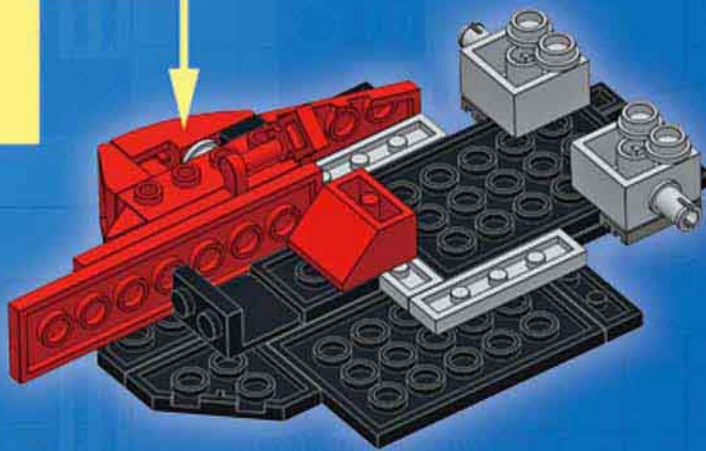
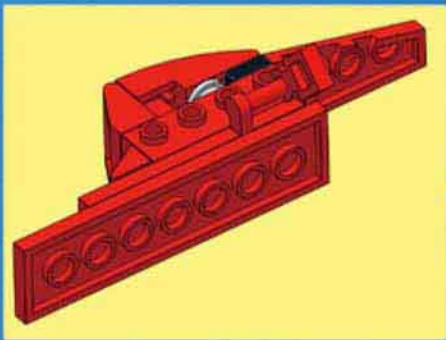

6

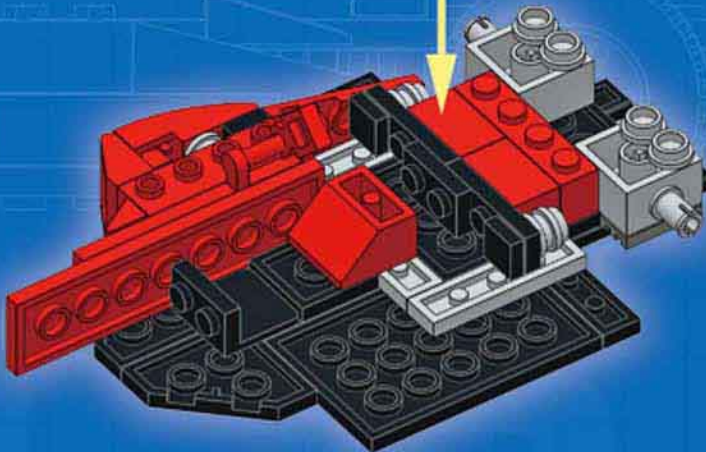
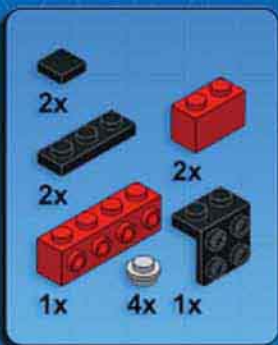



7

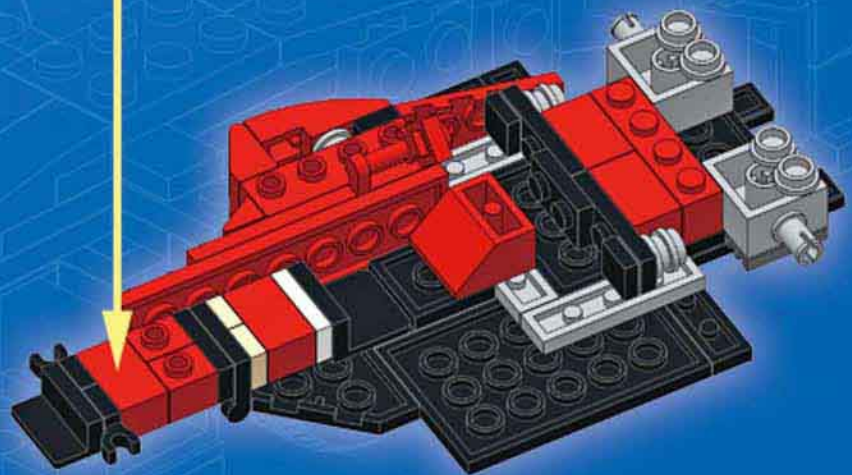
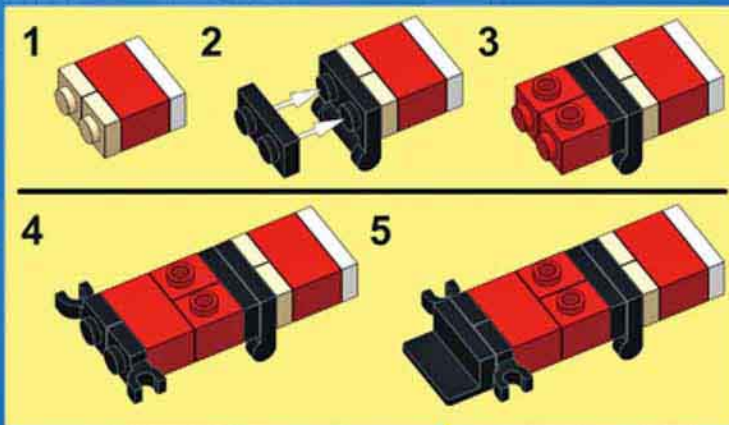
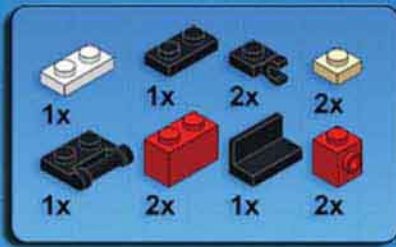



8

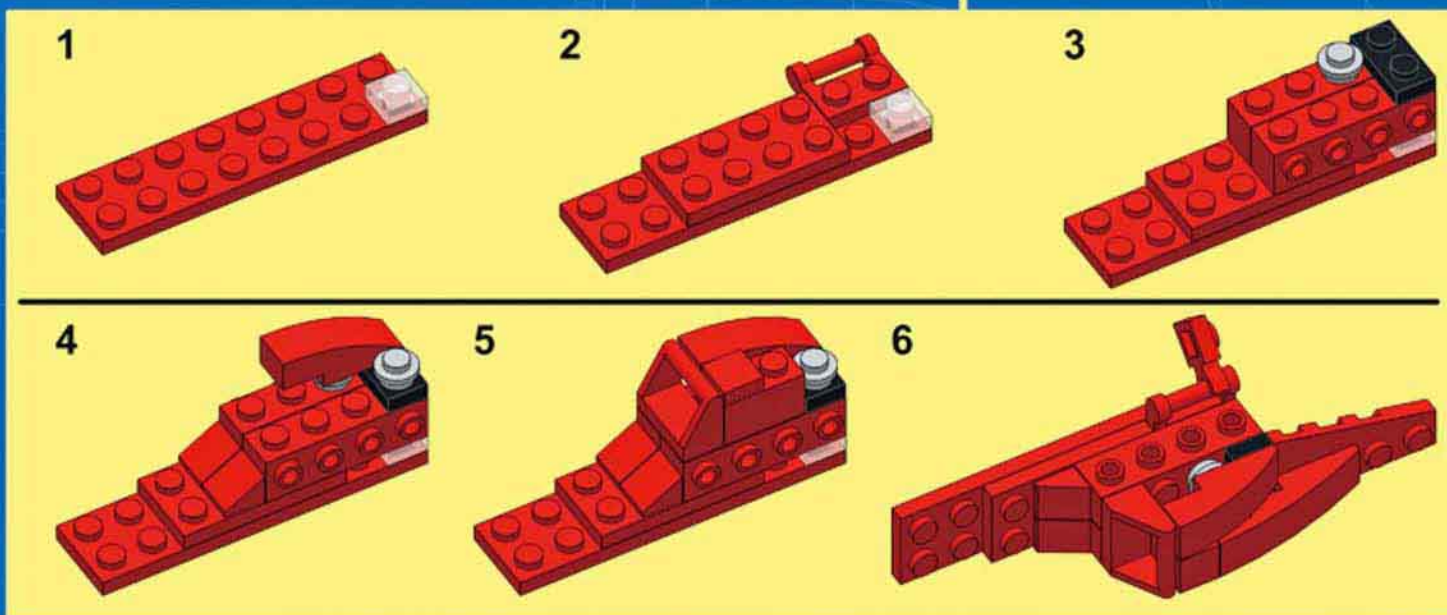
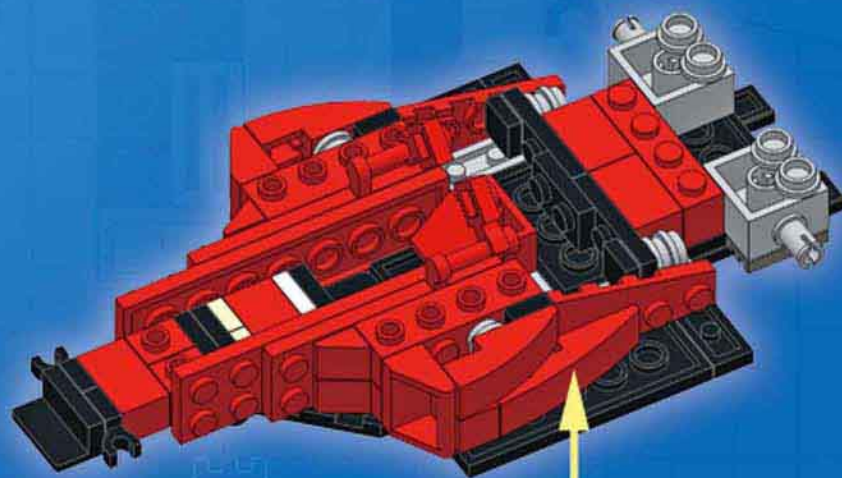
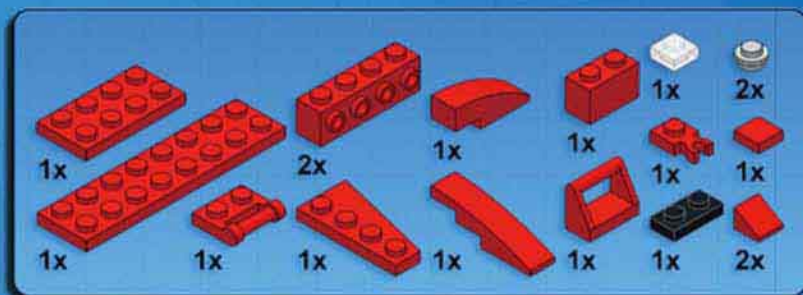



9

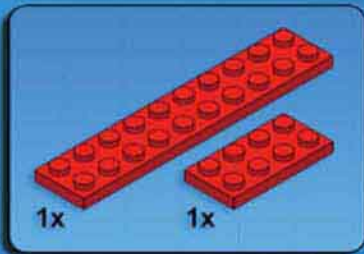

1

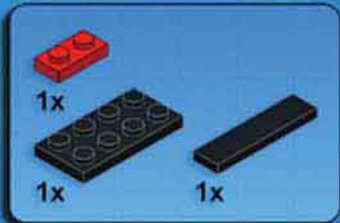
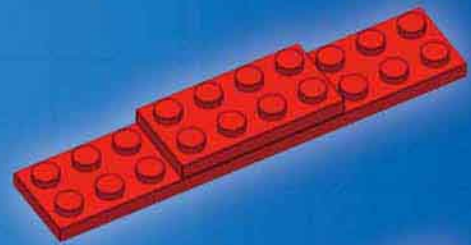

2

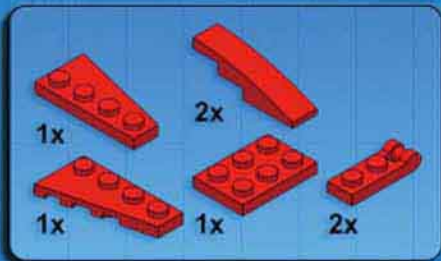
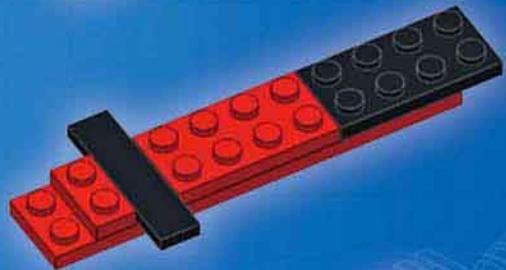

3

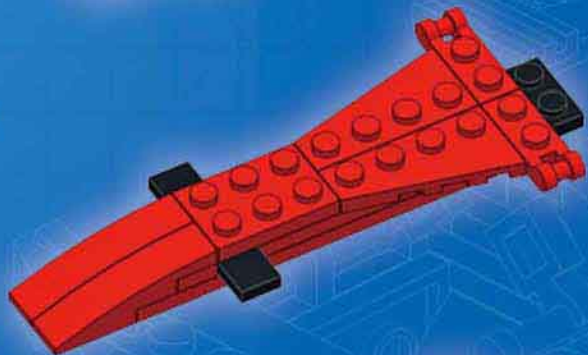

4

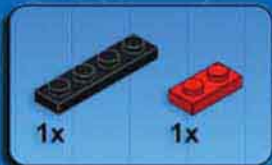
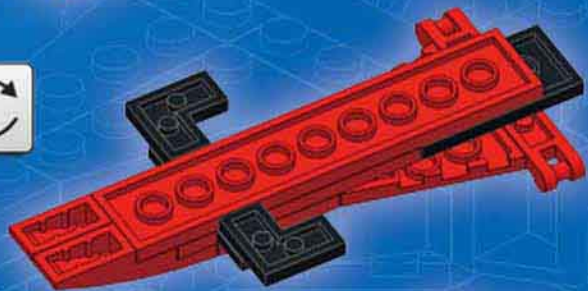

5

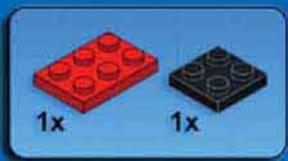
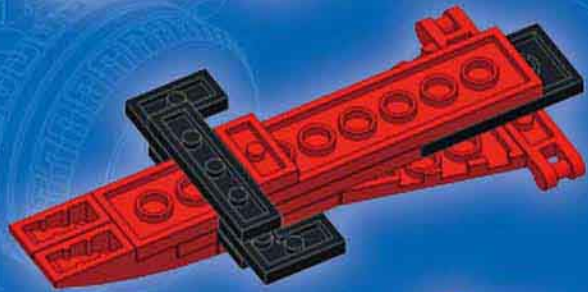

6

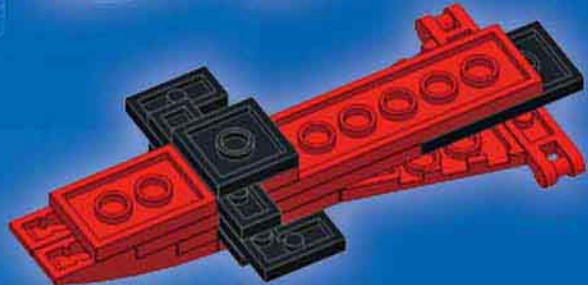

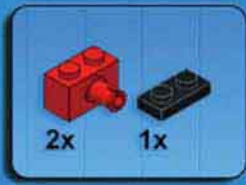

7

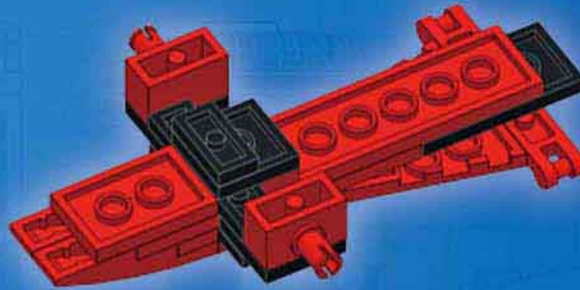

8

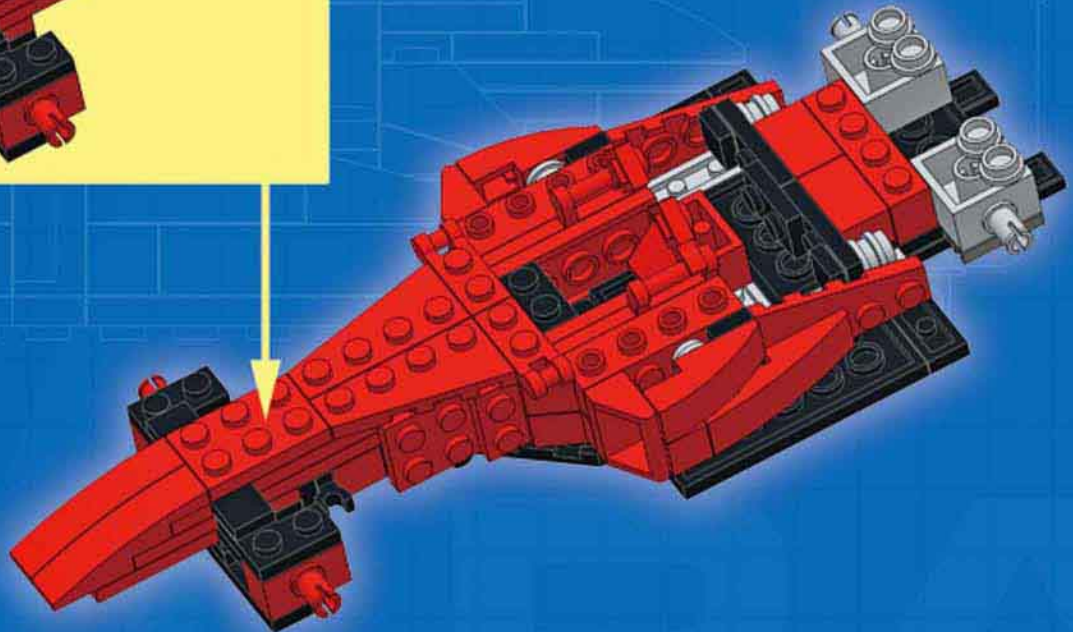
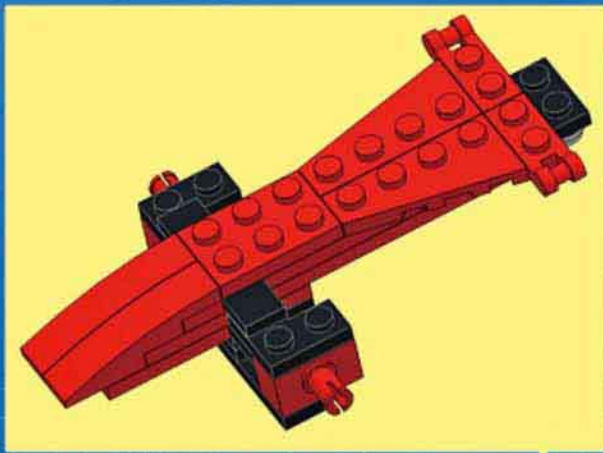
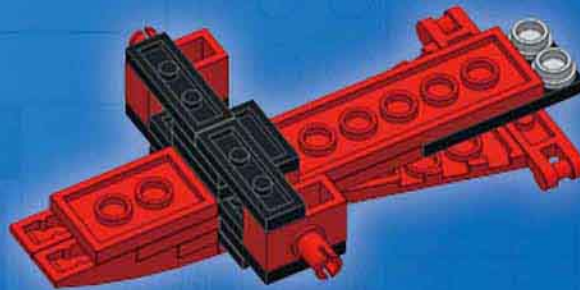



10

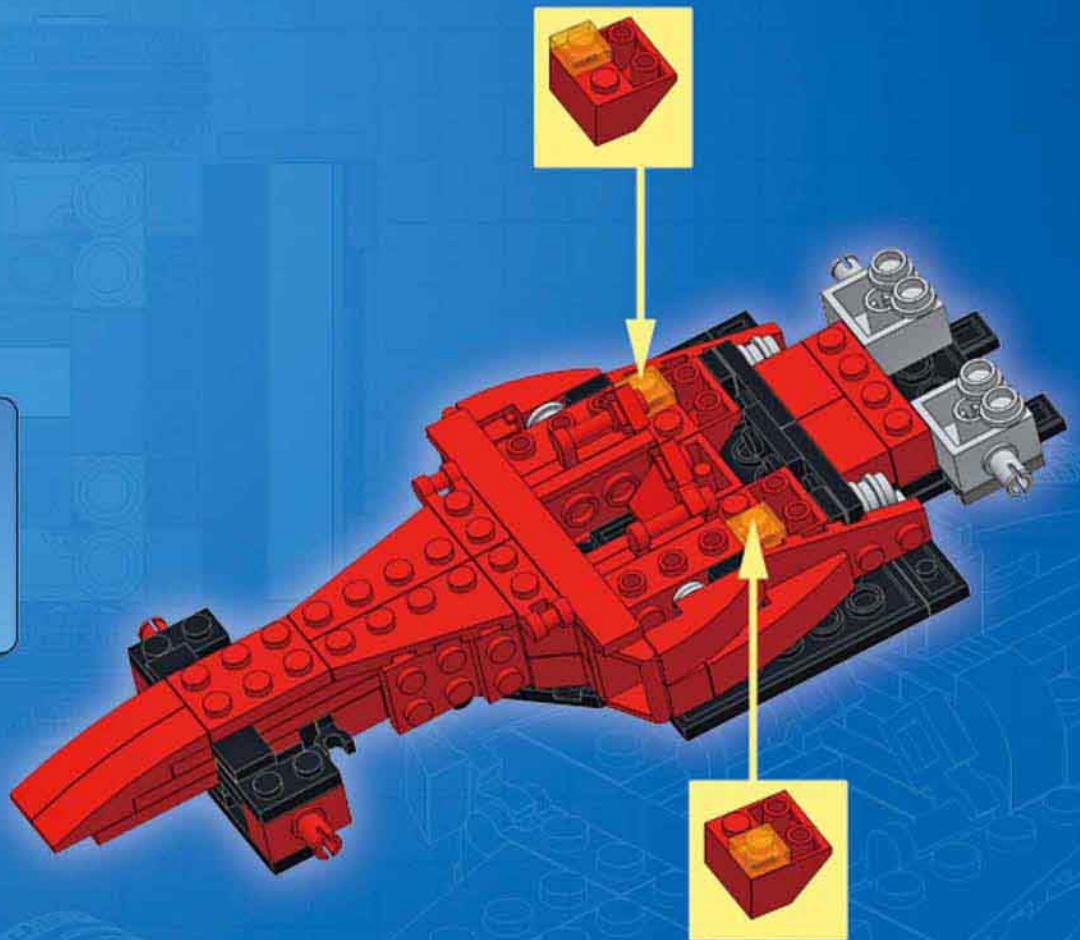
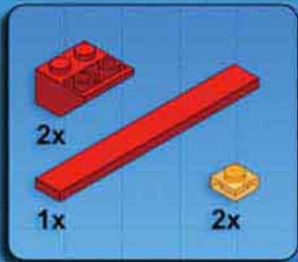

11

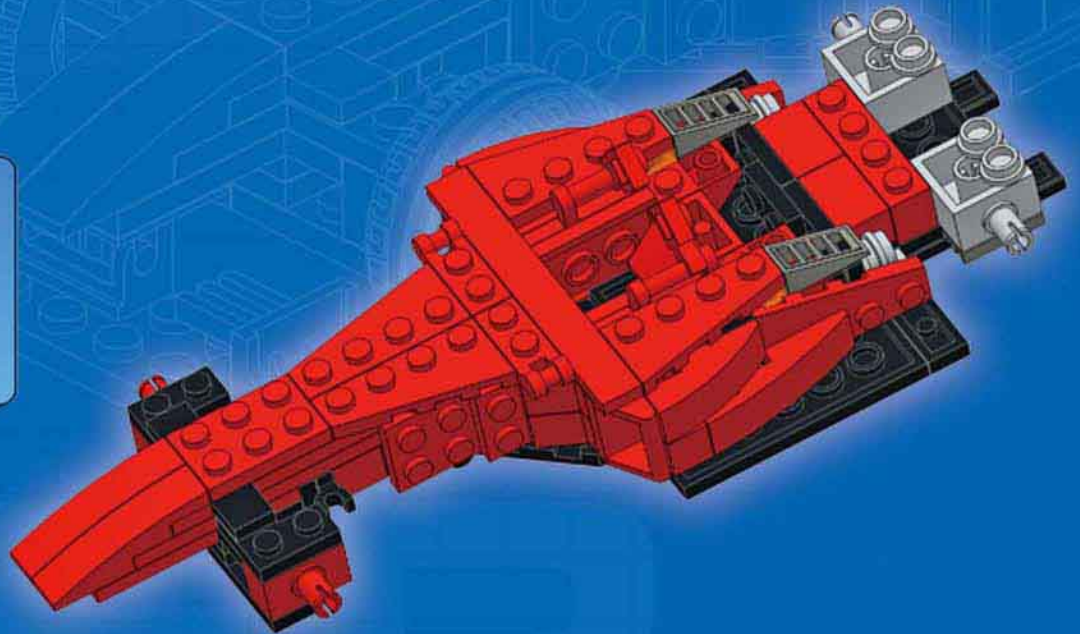
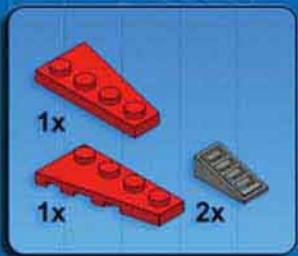



12

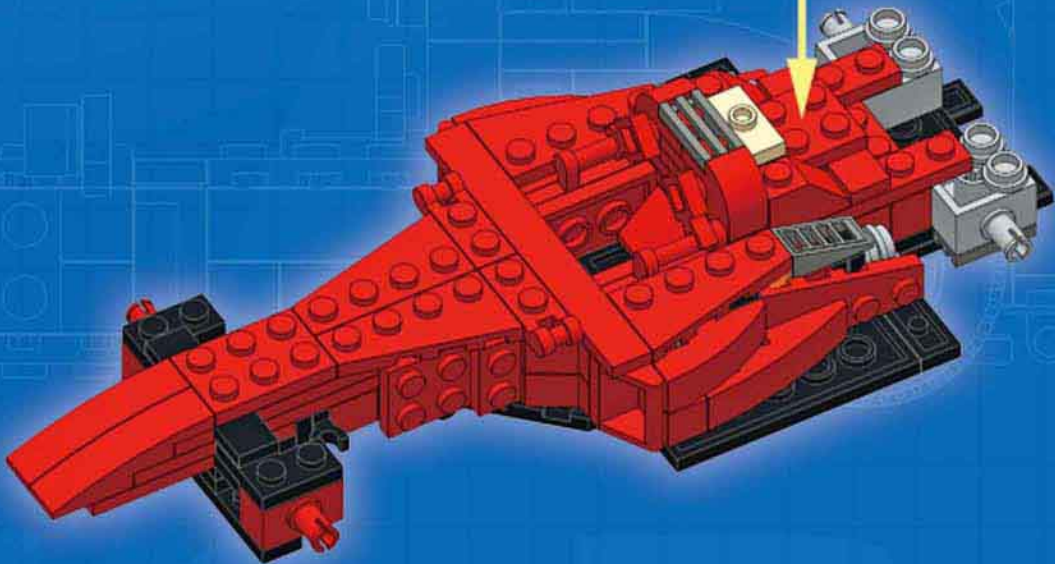
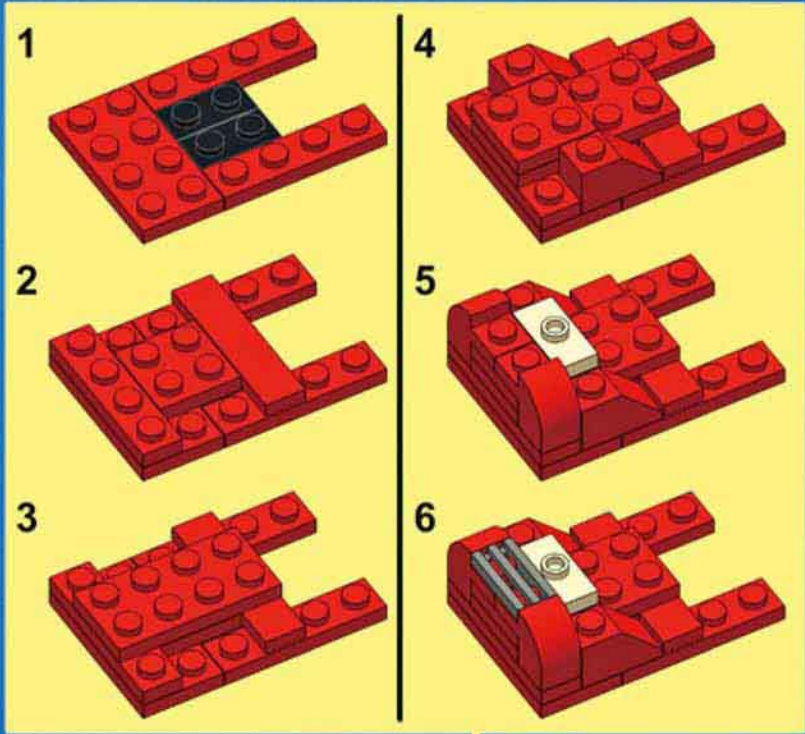
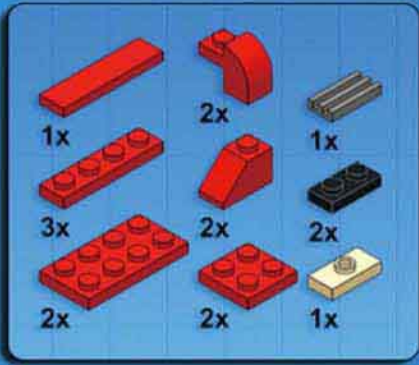





13

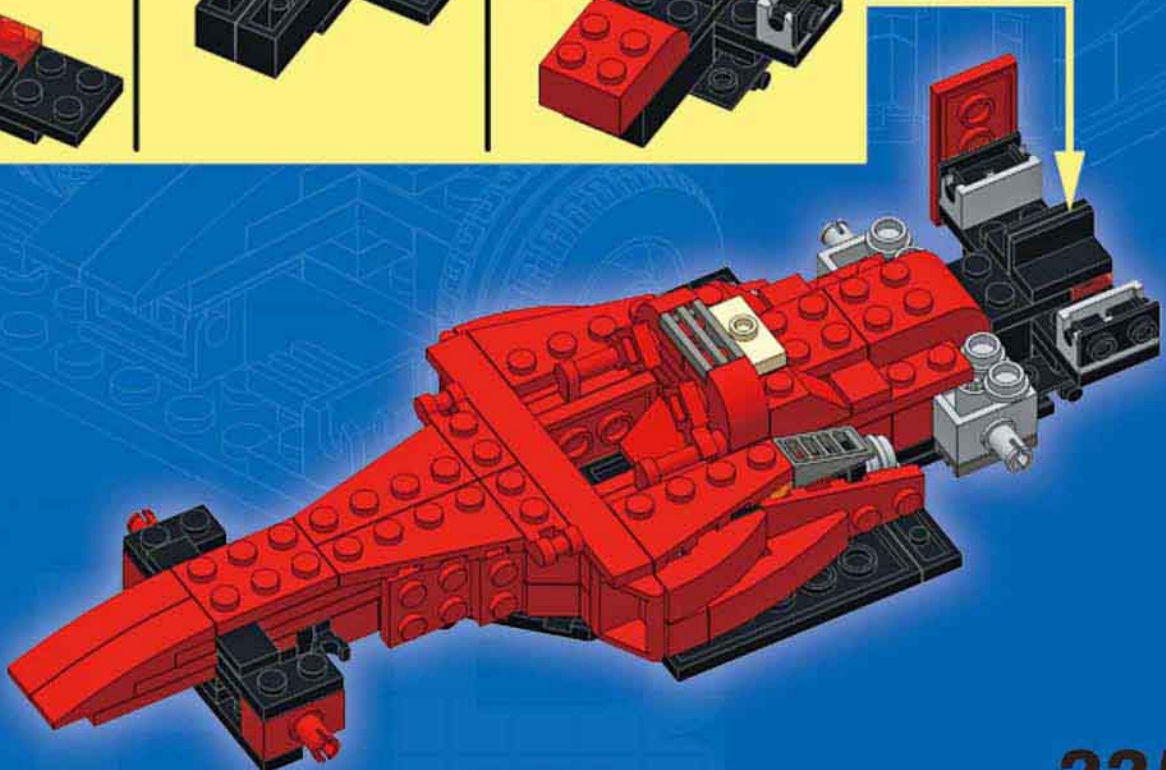
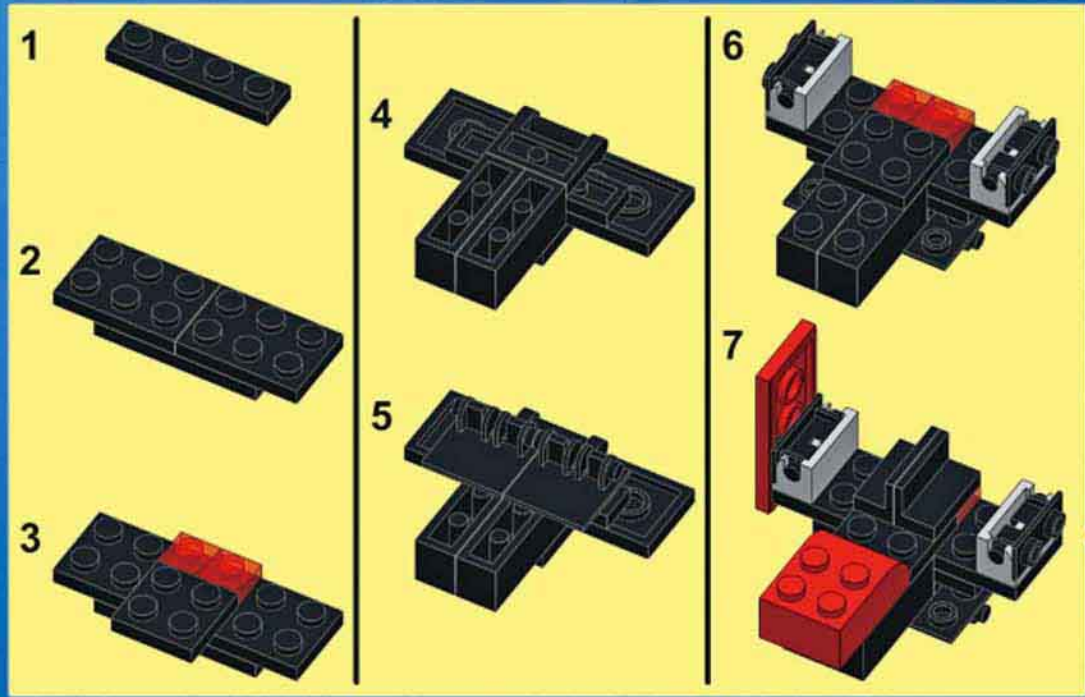
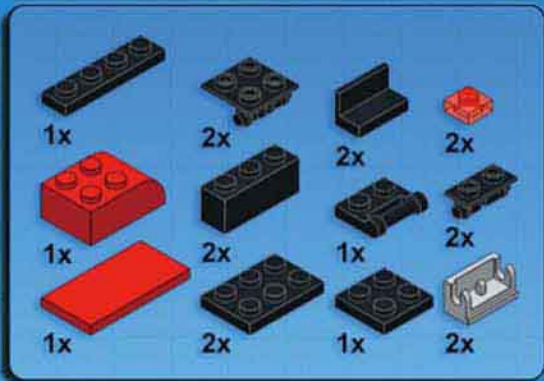



14

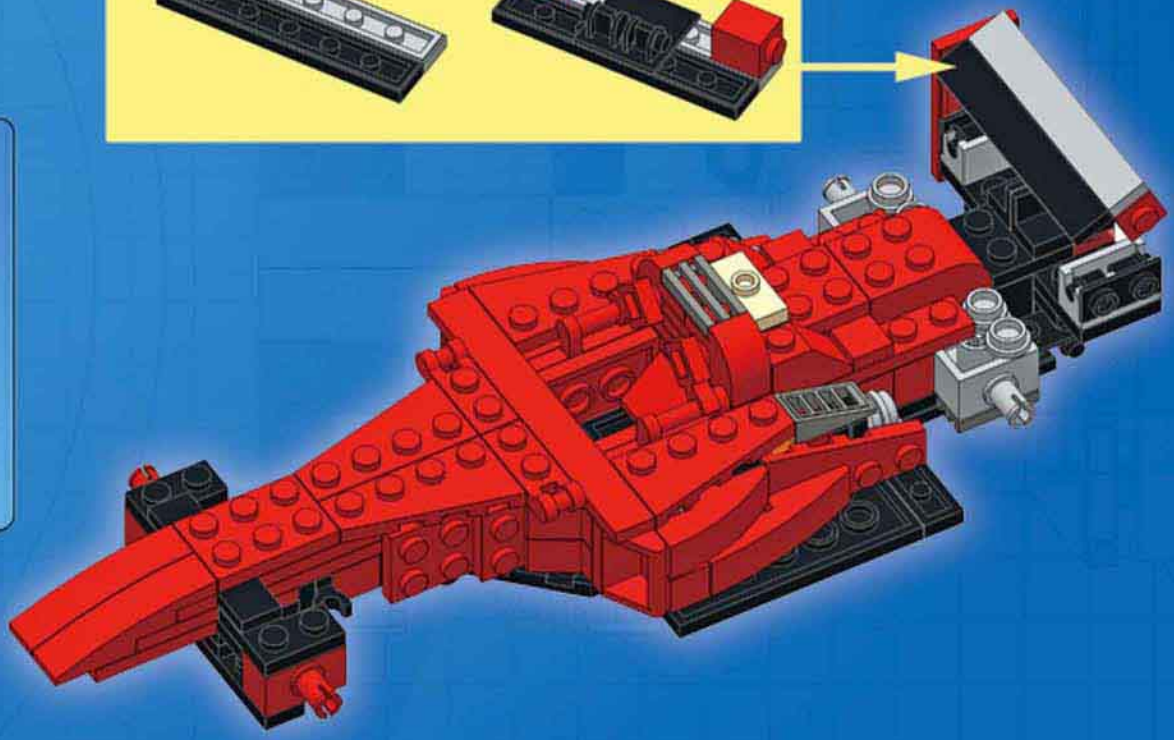
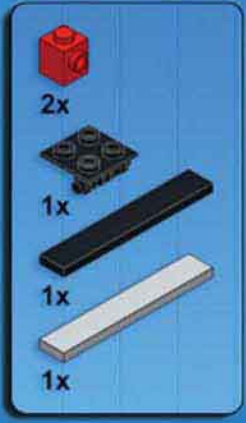
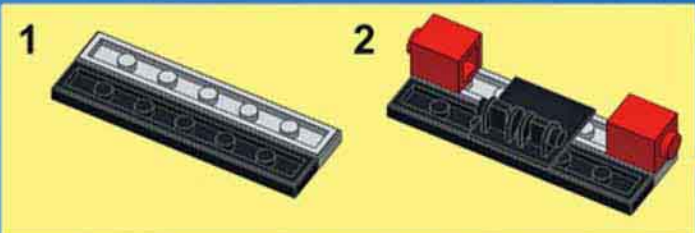

15

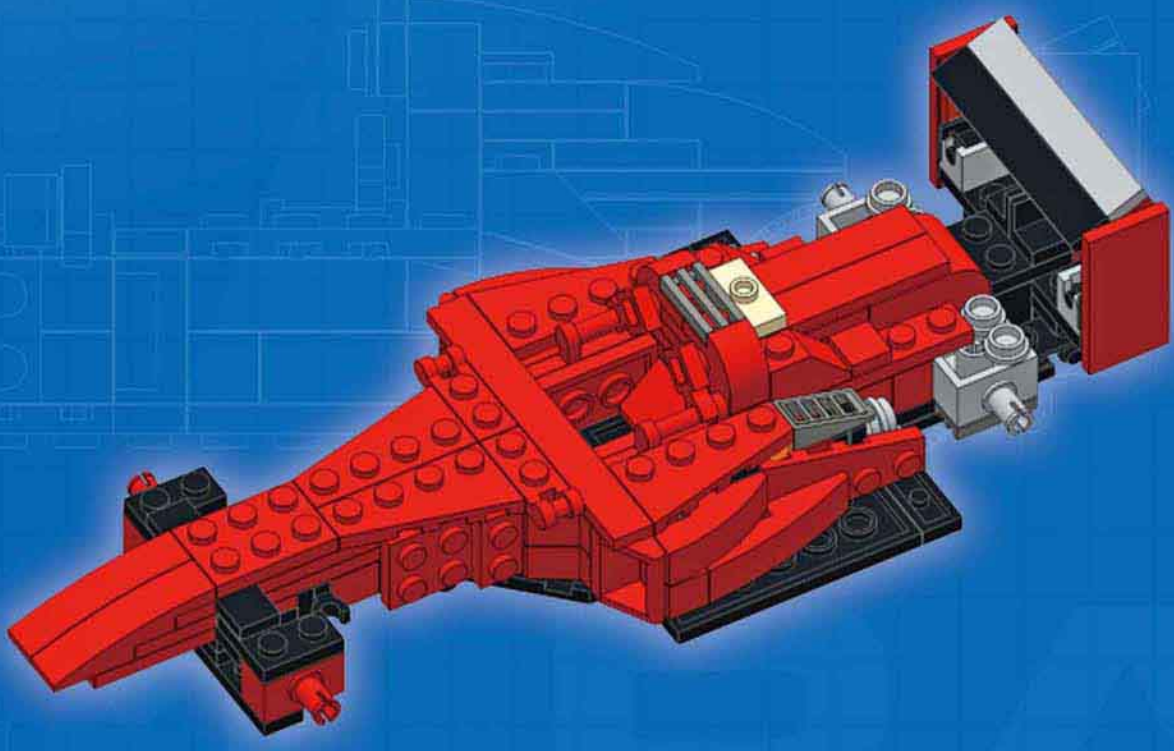
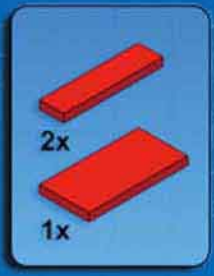



16

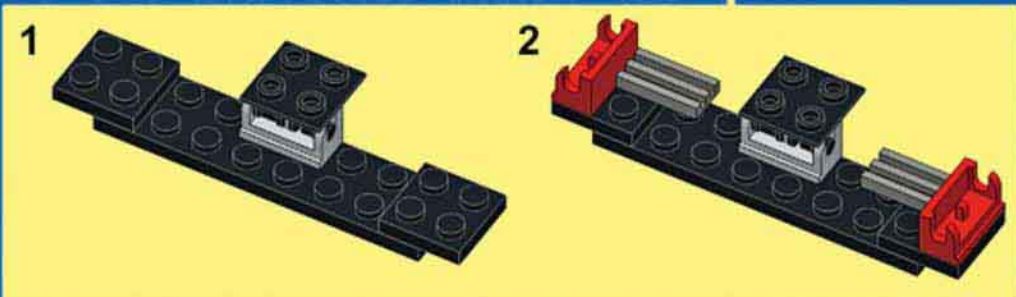
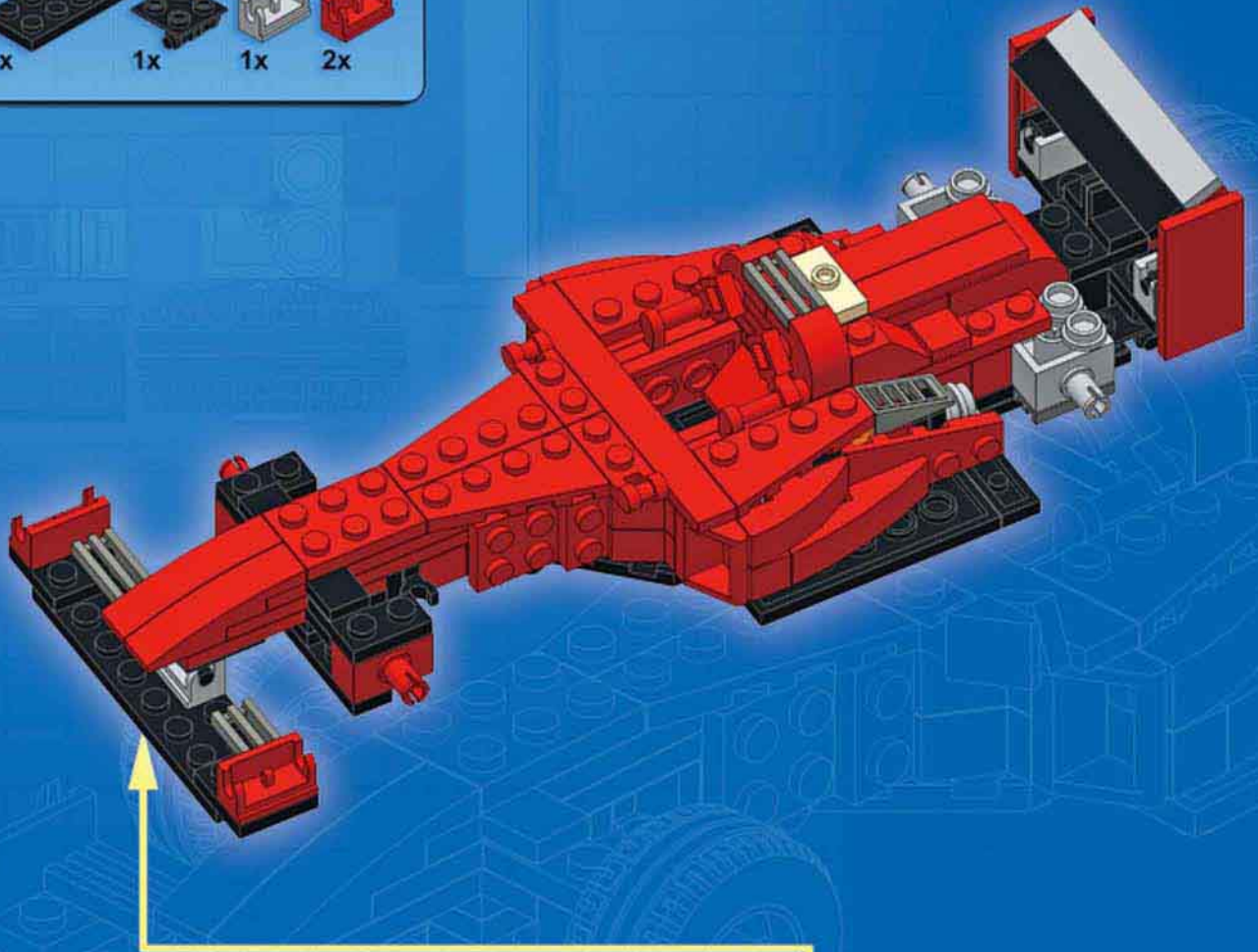
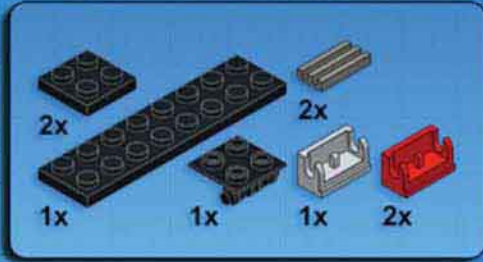

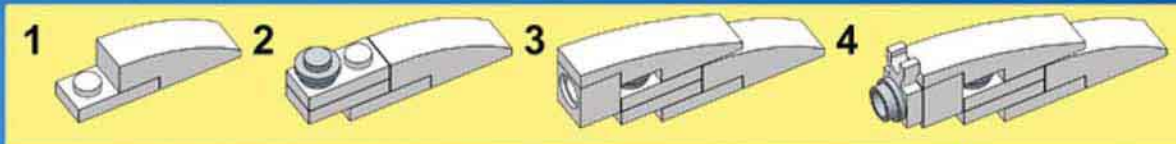

17

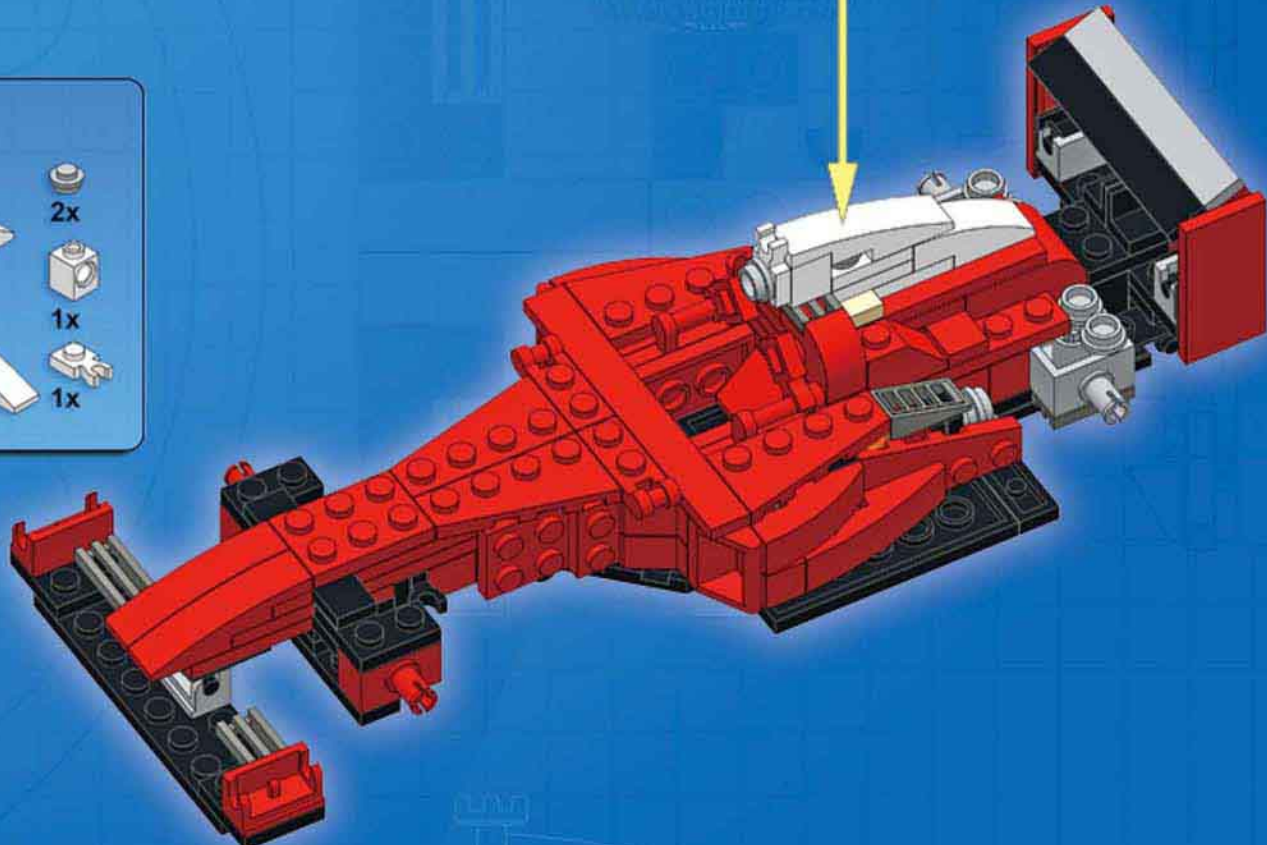
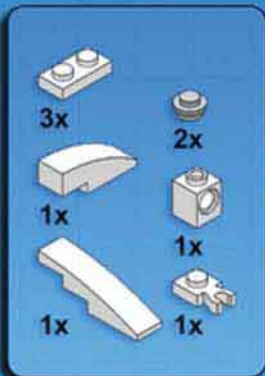

18

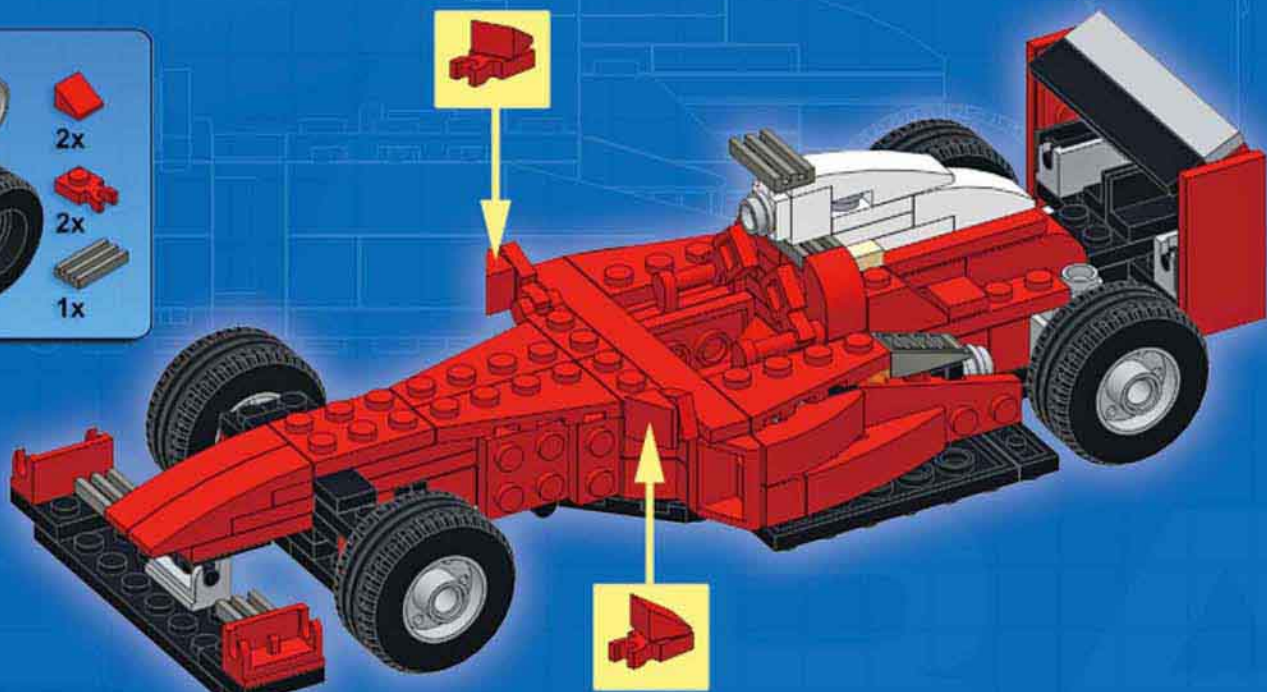



Complexity   
 Functions   
 Pieces 

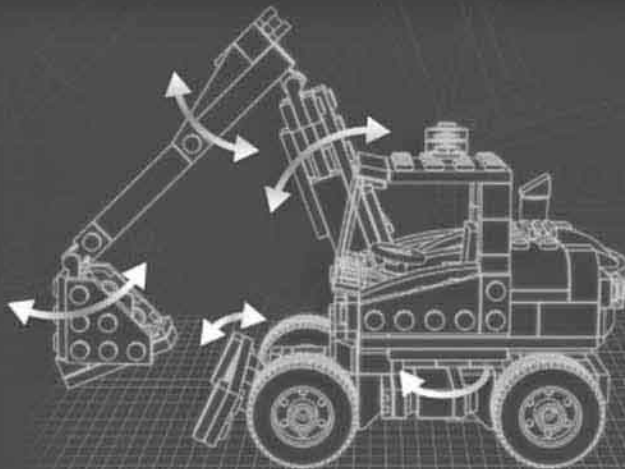

## EXCAVATOR

Design notes: short wheelbase, high clearance, offset cabin, vertical exhaust, hazard light

### Technical specifications:

Dimensions (l × w × h): 17 × 9 × 16 studs  
 Wheelbase: 9 studs  
 Axle width front/rear: 8/8 studs

Features: rotating turret; front blade; articulated arm, dipper, and bucket



1

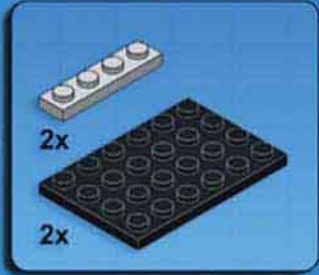

2

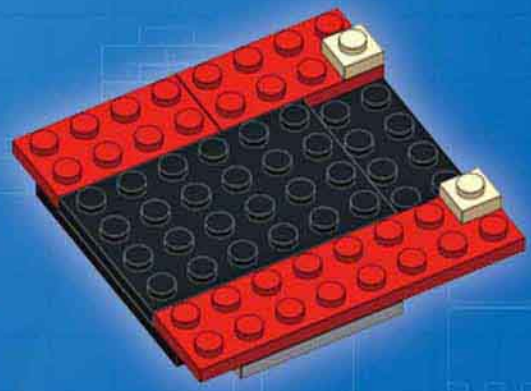
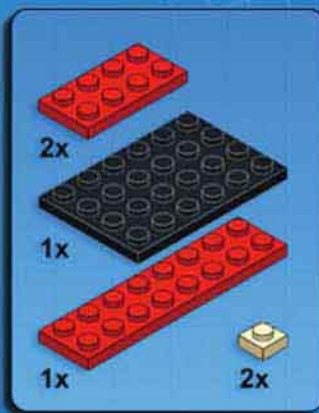

3

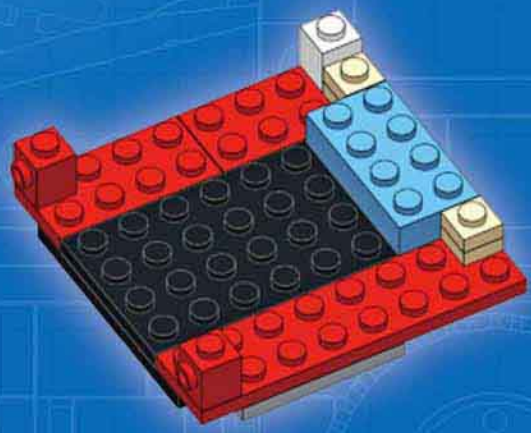
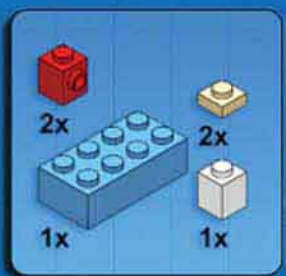

4

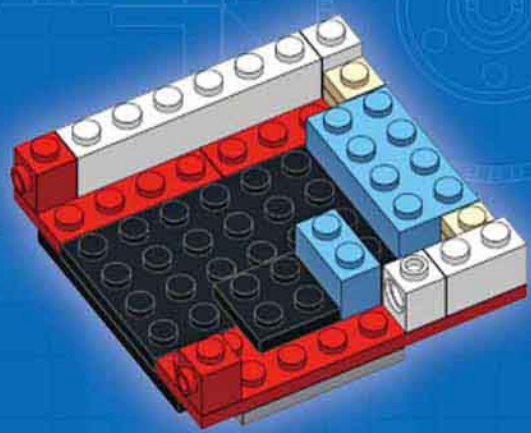
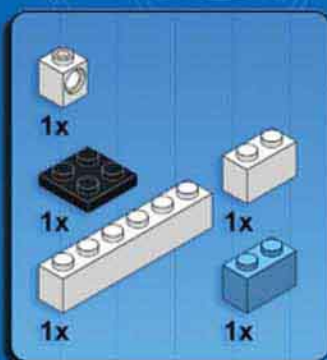

5

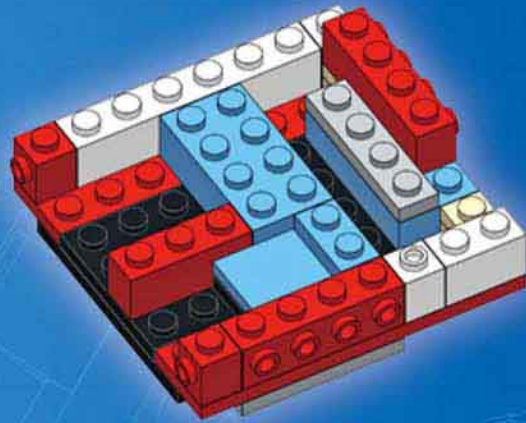
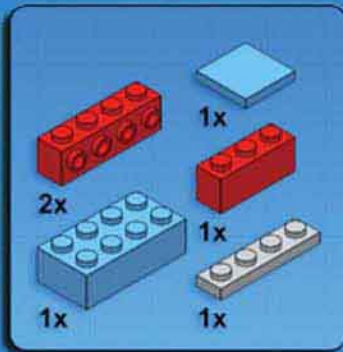

6

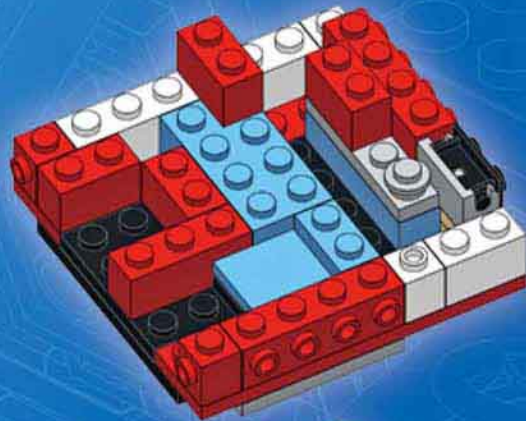

7

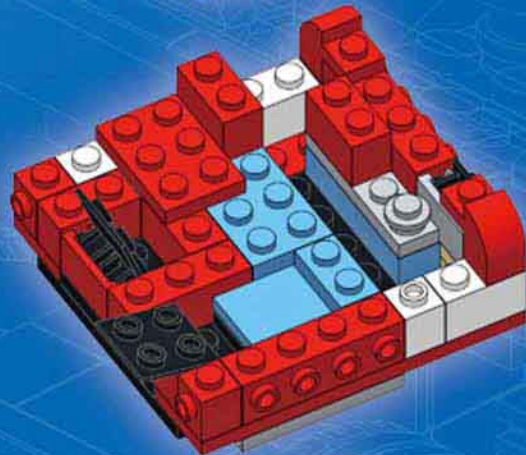
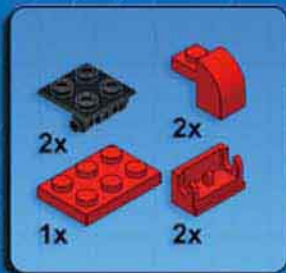

8

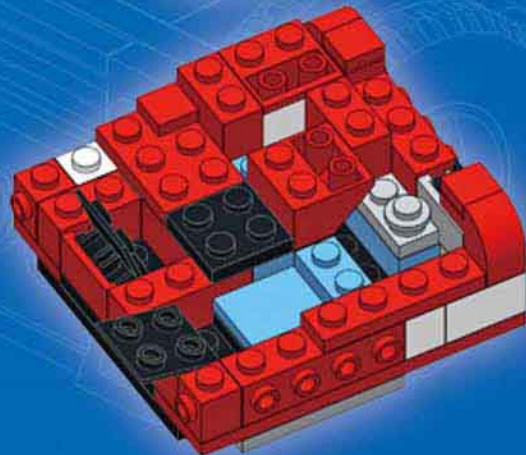
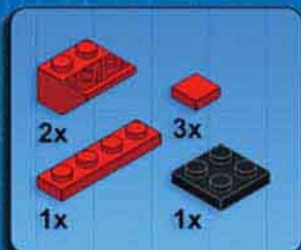



9

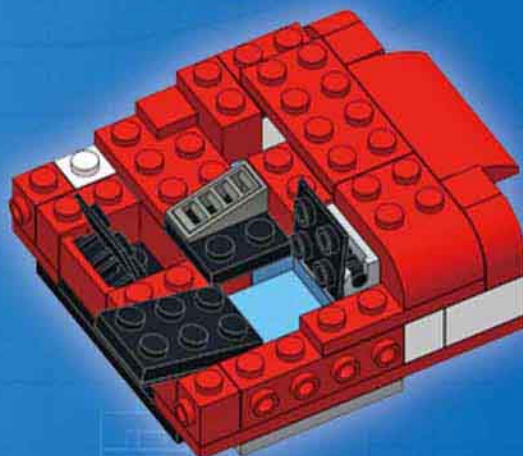
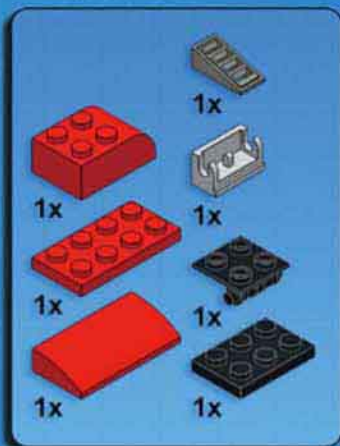

10

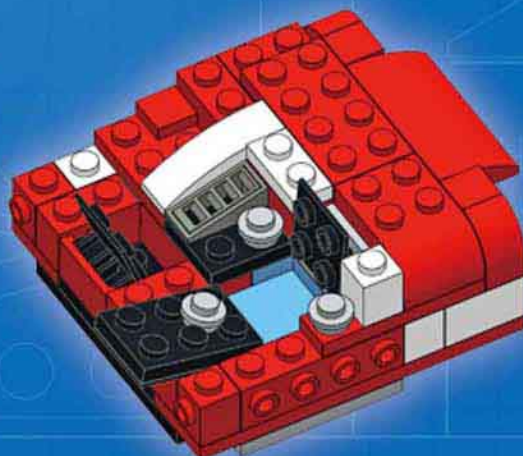
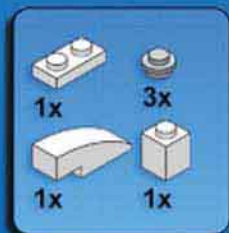

11

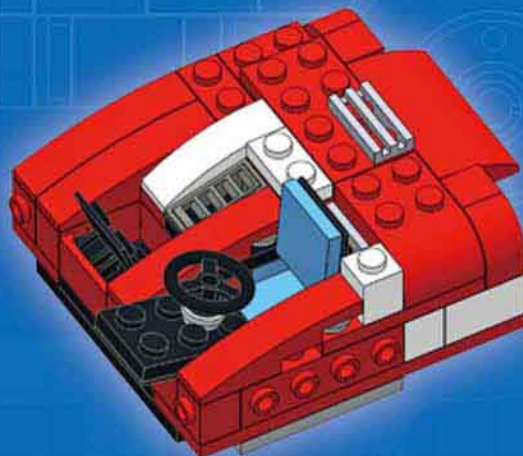
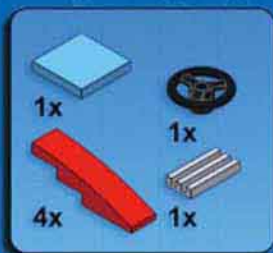



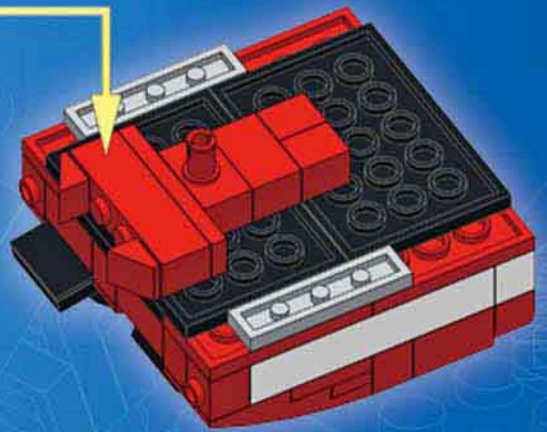
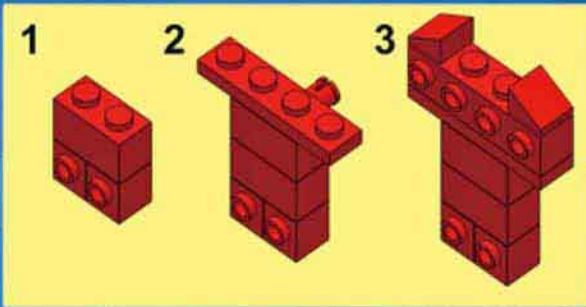

12

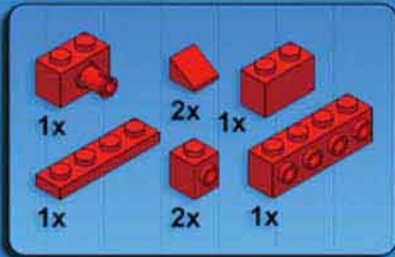

13

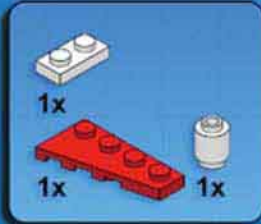
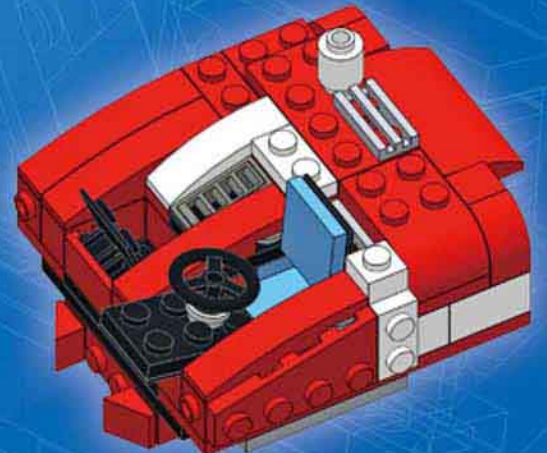

14

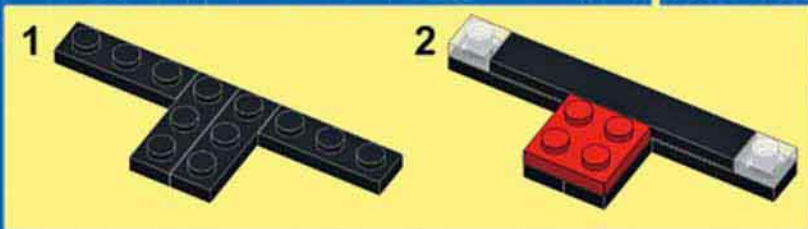
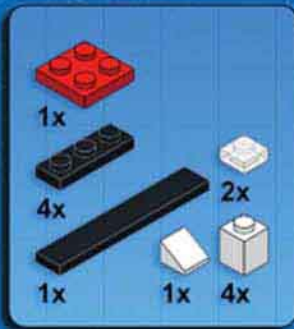
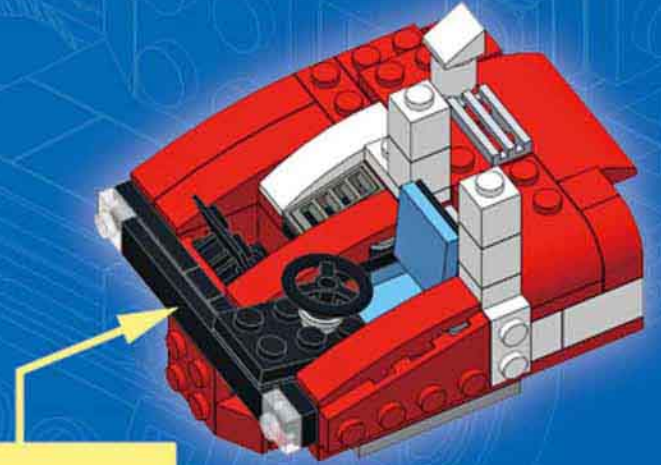



15

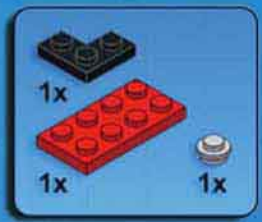

1

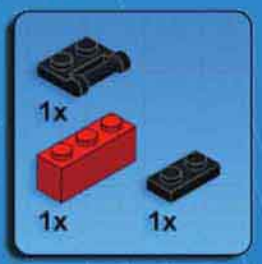

2

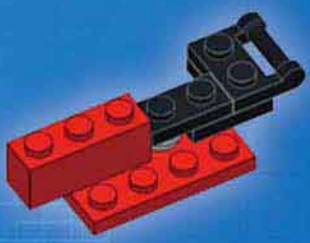

3

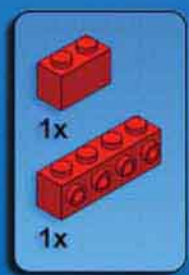
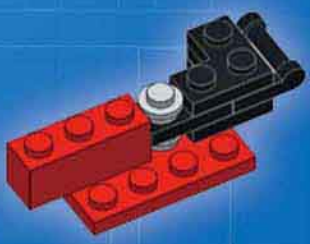

4

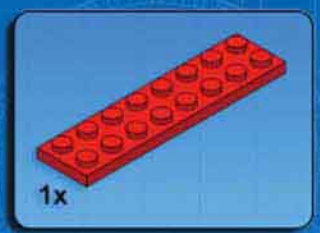
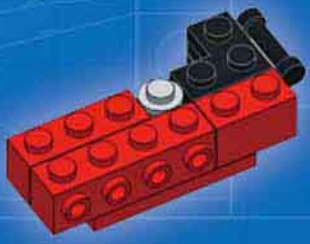

5

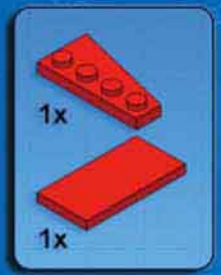
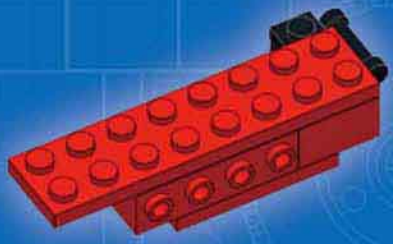

6

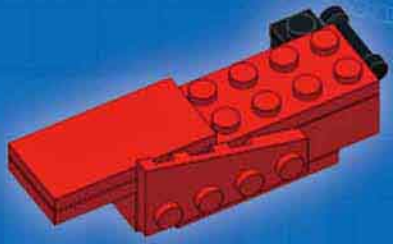

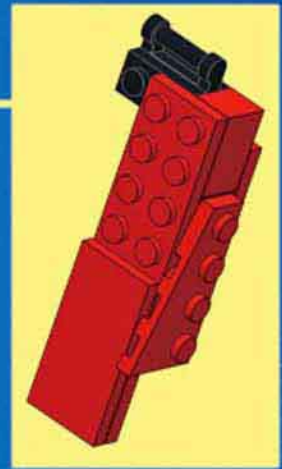

16

- 1x
- 2x
- 2x
- 2x
- 1x
- 2x
- 2x
- 2x

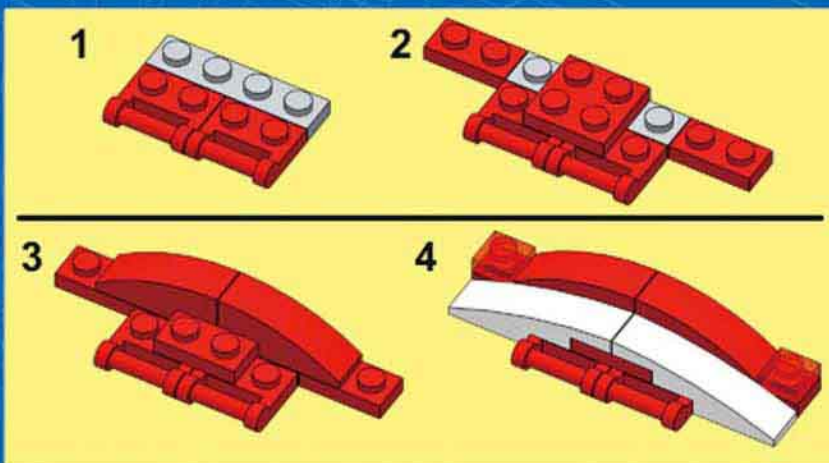
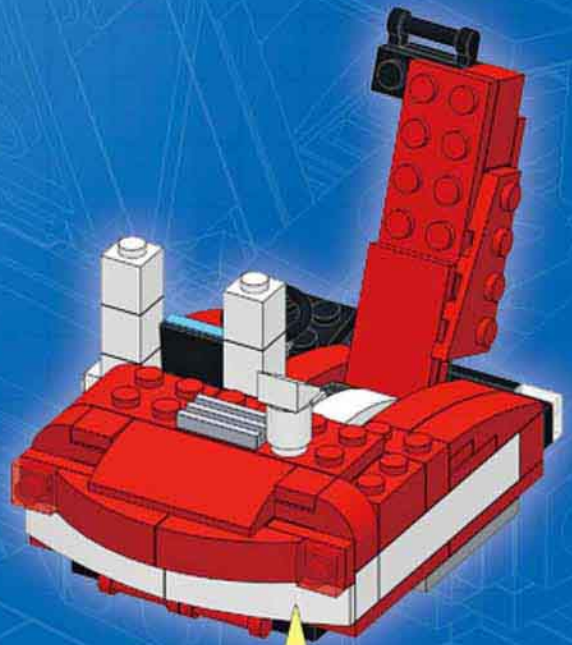



17

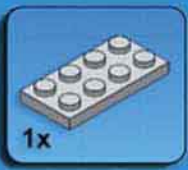

1

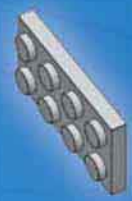

2



3

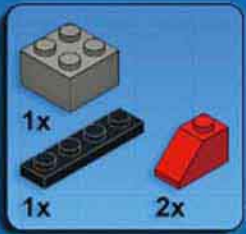

4

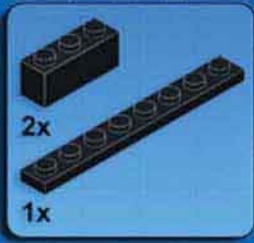

5

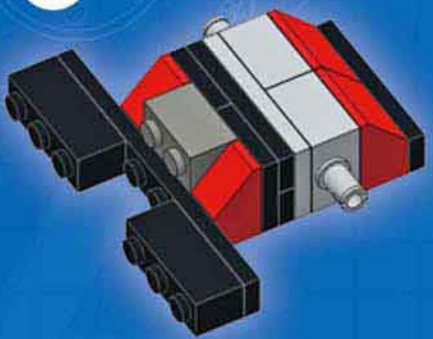

6

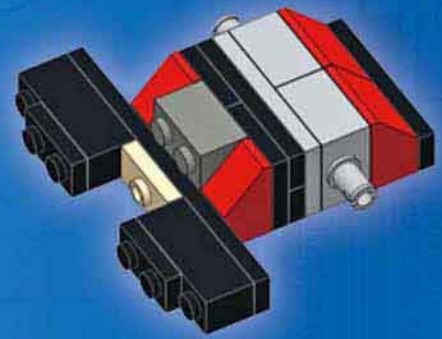

7

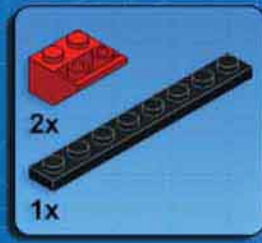
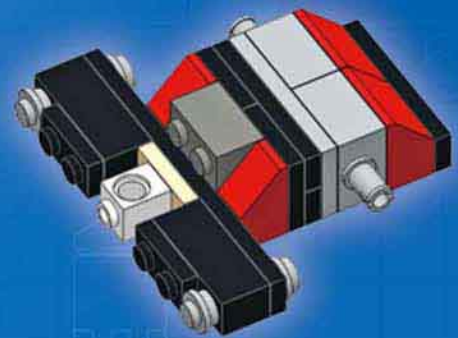

8

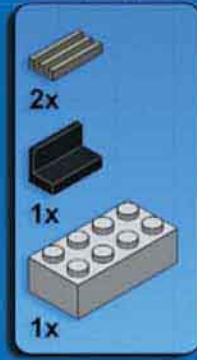
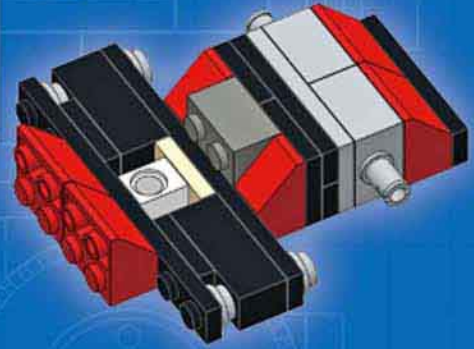

9

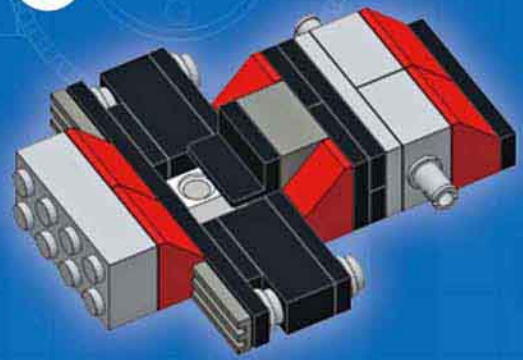

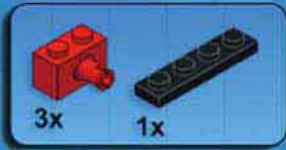

10

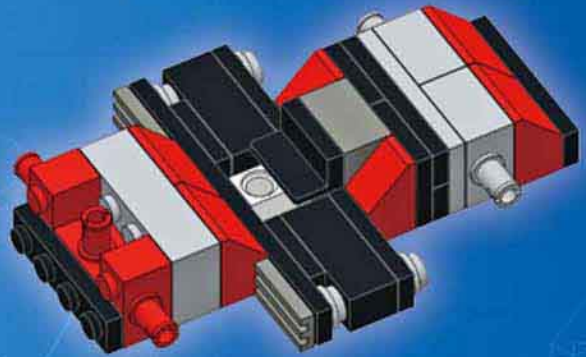

11

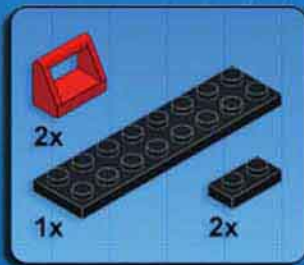
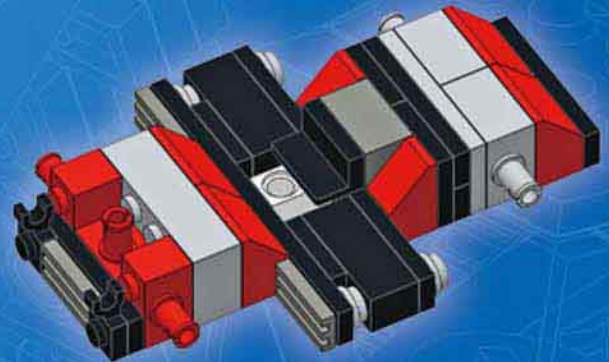

12

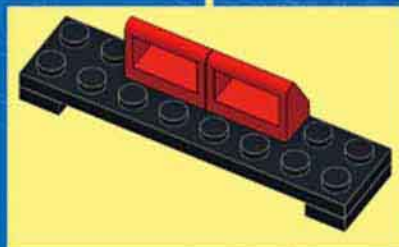
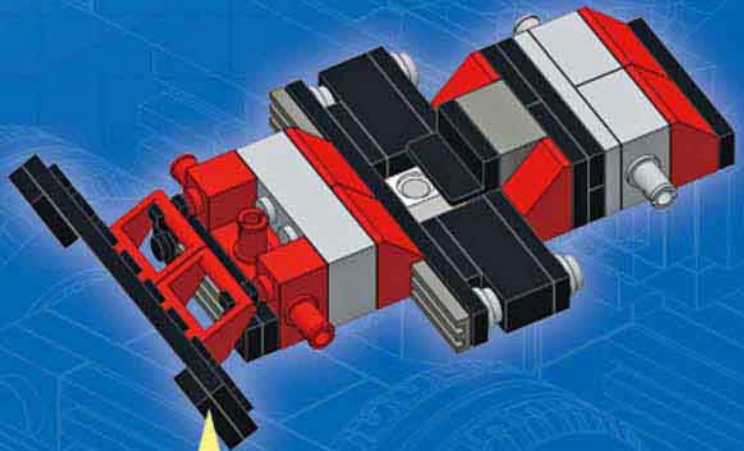

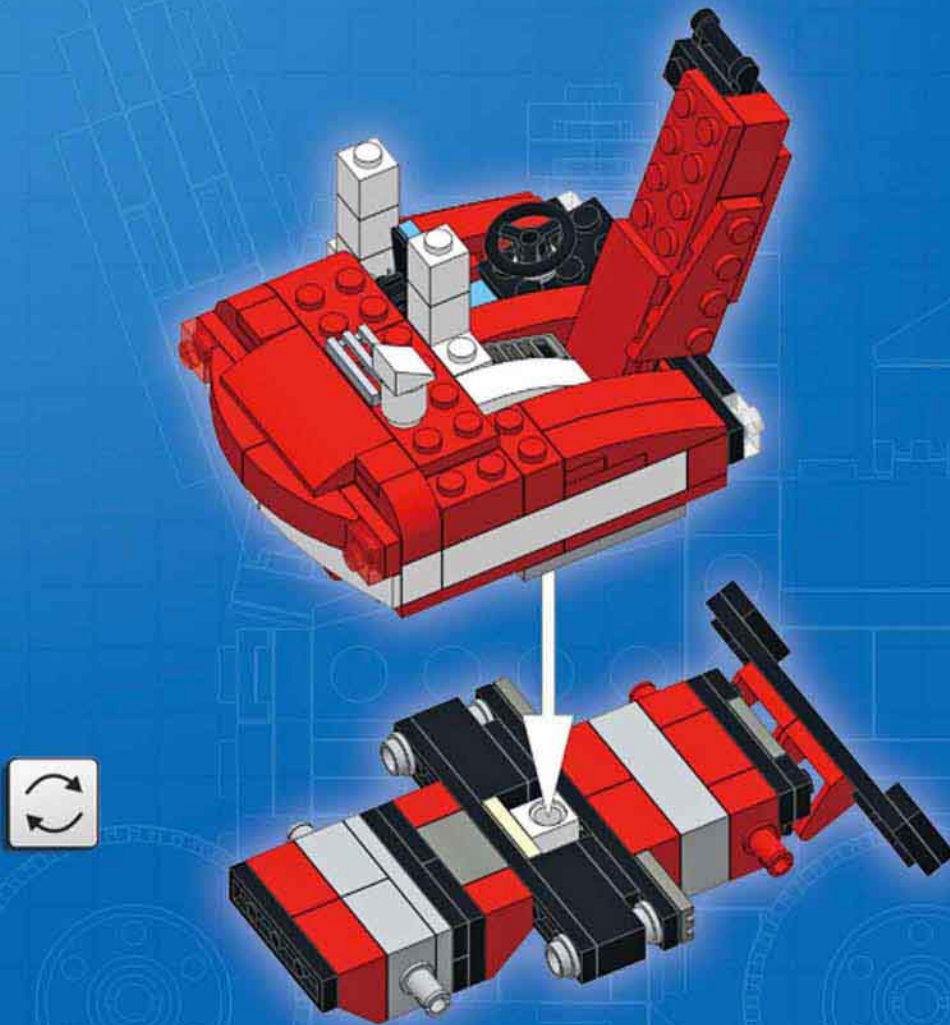

18

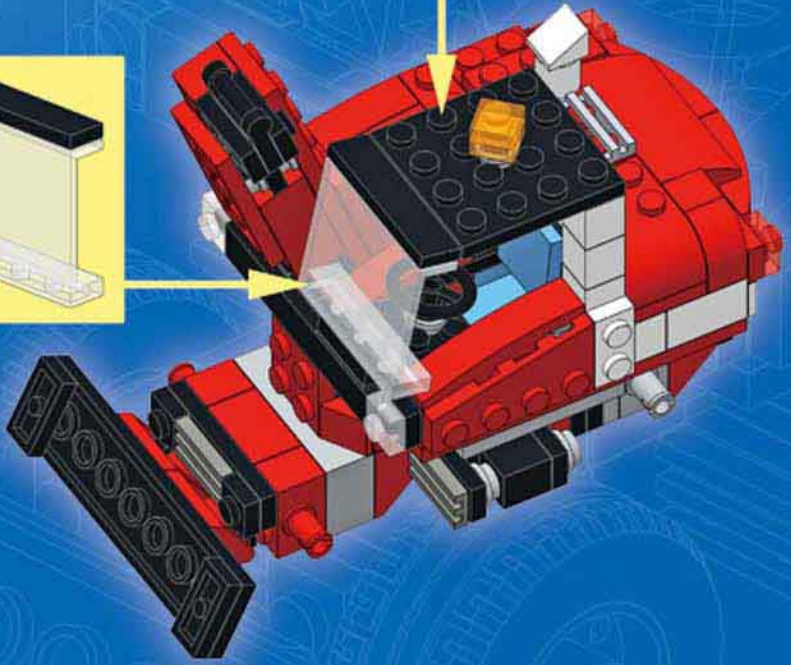
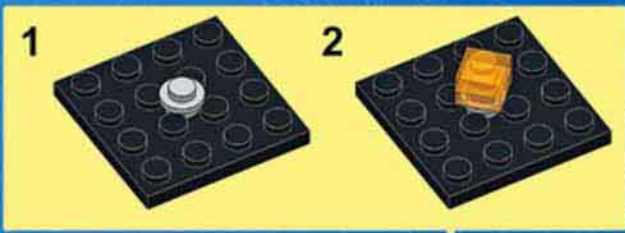



19

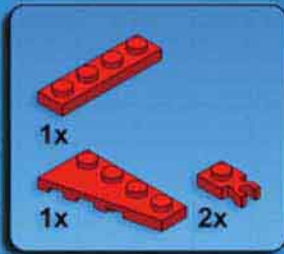

1

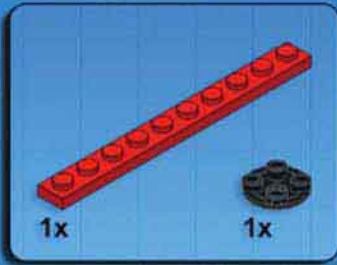
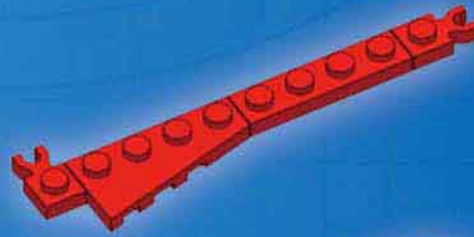

2

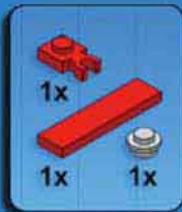
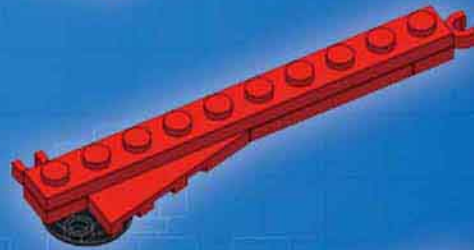

3

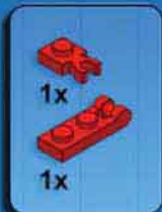
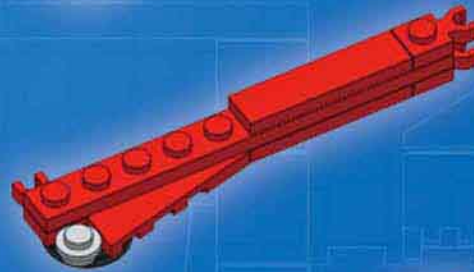

4

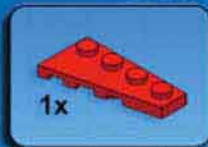
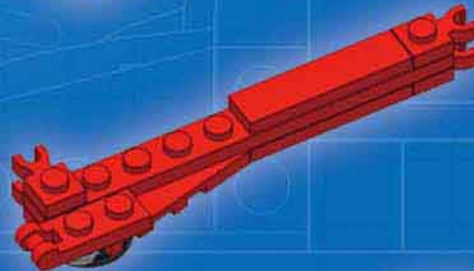

5

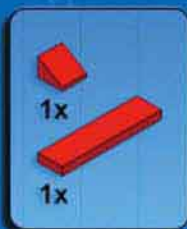
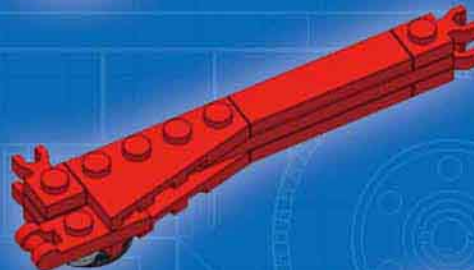

6





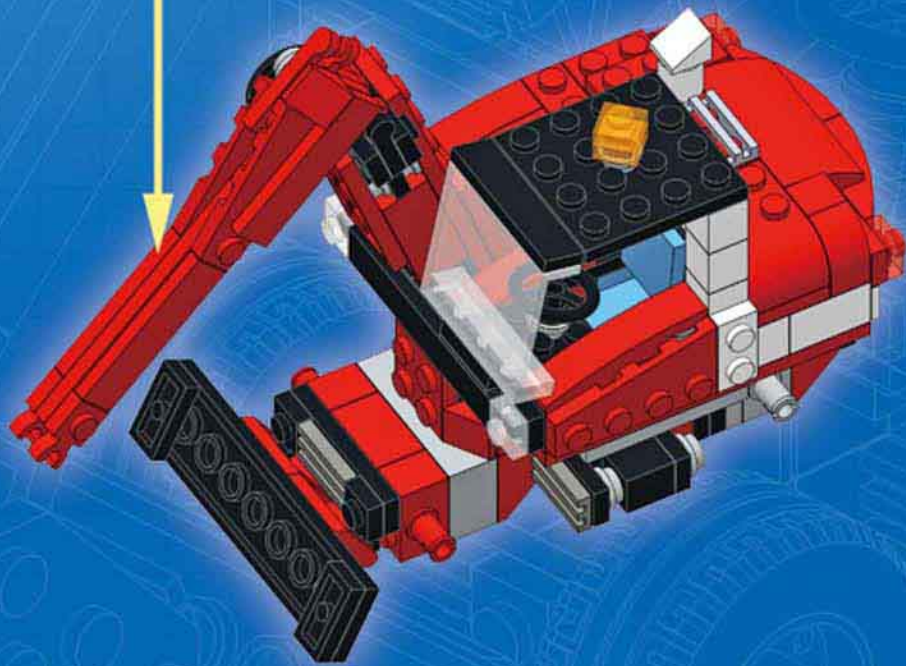
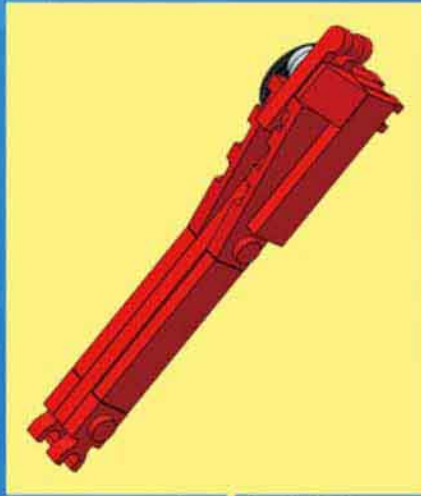



20



1



2



3



4



5



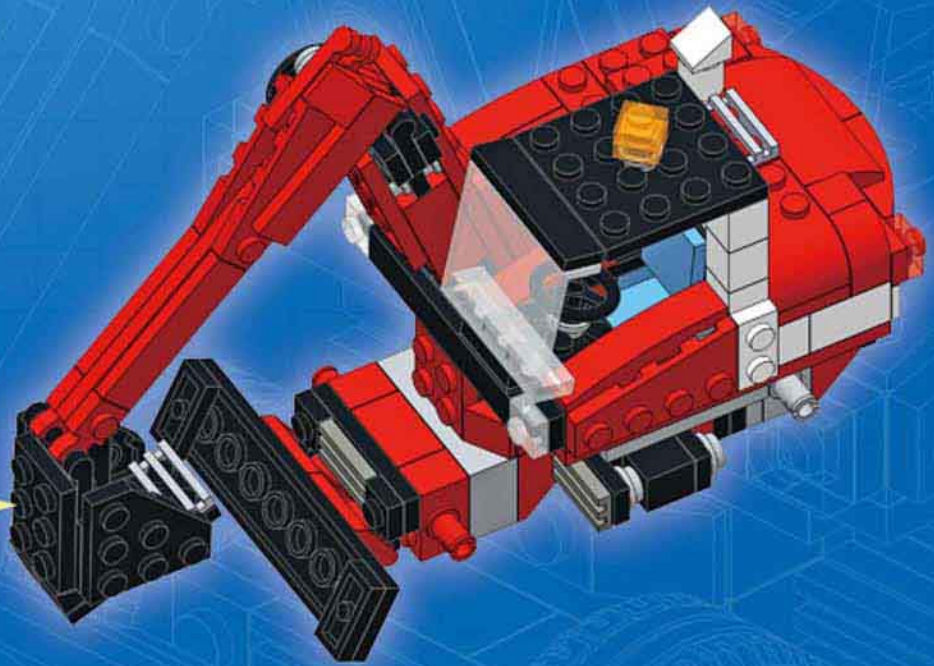



21

